



स्वास्थ्य एवं  
परिवार कल्याण मंत्रालय  
MINISTRY OF  
HEALTH AND  
FAMILY WELFARE

सत्यमेव जयते



राष्ट्रीय स्वास्थ्य मिशन



# LIFE SAVING ANAESTHESIA SKILLS CURRICULUM 2024





**LIFE SAVING  
ANAESTHESIA SKILLS  
CURRICULUM  
2024**





आराधना पटनायक, भा.प्र.से.  
अपर सचिव एवं मिशन निदेशक (रा.स्वा.पि.)

**Aradhana Patnaik, IAS**  
Additional Secretary & Mission Director (NHM)



सत्यमेव जयते



आजादी का  
अमृत महोत्सव

भारत सरकार  
स्वास्थ्य एवं परिवार कल्याण मंत्रालय  
निर्माण भवन, नई दिल्ली-110011

Government of India  
Ministry of Health and Family Welfare  
Nirman Bhawan, New Delhi-110011



## FOREWORD

The Ministry of Health and Family Welfare (MoHFW) is dedicated to reducing maternal and neonatal mortality and morbidity in alignment with SDG targets. Enhancing access to emergency obstetric care is crucial to lowering maternal mortality ratio. Anaesthesia plays a central role in providing comprehensive Emergency Obstetric Care, yet the shortage of anaesthetist and Gynaecologist poses a significant challenge nationwide.

Initiatives such as Comprehensive Emergency Obstetric & Newborn Care (CEmONC) and Life Saving Anaesthetic Skills (LSAS) are essential for addressing these gaps and realizing the Government of India's vision of zero preventable maternal and newborn deaths. These efforts aim to equip medical officers with the skills to manage obstetric emergencies, thereby strengthening the establishment of First Referral Units (FRUs). Additionally, initiatives like Surakshit Matritva Aashwasan (SUMAN), Pradhan Mantri Surakshit Matritva Abhiyan (PMSMA), LaQshya, and the Midwifery program ensure the provision of high-quality maternal and newborn health services with adequate trained personnel and infrastructure.

Timely reorientation of medical officers is crucial for continuous improvement in service delivery, enabling facilities to effectively handle pregnancy-related complications and newborn care. The Life Saving Anaesthetic Skills (LSAS) curriculum has been updated following extensive consultations with field experts and state inputs. This revised curriculum, based on the latest evidence-based protocols, is expected to enhance training quality, ensuring more doctors are proficient in providing life saving anaesthetic skill in the designated FRUs.

I trust that Mission Directors, state and district program officers, and training institutes will utilize the updated curriculum effectively to operationalize FRUs and elevate the standards of obstetric and newborn services.

Dated: 9<sup>th</sup> October, 2024

  
(Aradhana Patnaik)







सत्यमेव जयते

**Meera Srivastava, IRS**  
Joint Secretary

भारत सरकार  
स्वास्थ्य एवं परिवार कल्याण मंत्रालय  
निर्माण भवन, नई दिल्ली-110011

Government of India  
Ministry of Health and Family Welfare  
Nirman Bhawan, New Delhi-110011



### MESSAGE

Reproductive and Child Health has been a crucial pillar of the healthcare system, focusing significantly on maximizing institutional deliveries and ensuring safe intrapartum care. Janani Suraksha Yojana (JSY), Janani Shishu Suraksha Karyakram (JSSK), Pradhan Mantri Surakshit Matritva Abhiyan (PMSMA), Skilled Birth Attendant (SBA) training, BEmONC, and CEmONC are longstanding initiatives aimed at promoting safe delivery and safeguarding the health of mothers and newborns.

In cases of obstetric complications, Caesarean section is often the preferred method of delivery. As a surgical procedure, anaesthesia is essential for performing a C-section, and its effective administration significantly influences surgical outcomes. However, ensuring adequate anaesthesia services, particularly in rural and underserved areas, remains a challenge.

The Life Saving Anaesthesia Skills (LSAS) course, initiated in 2003, was an 18-week training program designed for MBBS doctors already in service. This initiative facilitated the operationalization of First Referral Units (FRUs) across States/UTs, significantly improving maternal and newborn care services and saving lives during obstetric emergencies.

The curriculum for LSAS has undergone revision to emphasize practical skills through video demonstrations, simulated scenarios with mannequins, case studies, and integration of the latest evidence-based practices based on expert inputs. The duration has been extended to 24 weeks, including six weeks of hands-on training at district hospitals.

Enhanced anaesthesia services contribute to overall healthcare system efficacy by reducing complications, hospital stays, and associated healthcare costs. I hope that the revised curriculum will assist states and union territories in enhancing the quality of anaesthesia care services within our public health facilities.

(Ms. Meera Srivastava)







**Dr. Pawan Kumar**

MBBS, MD, DNB, MBA

Additional Commissioner, Incharge (MH & Immunization)



सत्यमेव जयते



आज़ादी का  
अमृत महोत्सव

भारत सरकार  
स्वास्थ्य एवं परिवार कल्याण मंत्रालय  
निर्माण भवन, नई दिल्ली-110011

GOVERNMENT OF INDIA  
MINISTRY OF HEALTH & FAMILY WELFARE  
NIRMAN BHAWAN, NEW DELHI - 110011



#### ACKNOWLEDGEMENT

Ensuring access to assured and quality emergency obstetric care near communities is crucial for reducing maternal and neonatal health risks and fatalities. In support of this vision, the Government of India facilitated the establishment of First Referral Units (FRUs), equipped with essential infrastructure, equipment, and blood bank/Storage facilities. However, the shortage of anaesthetist in peripheral public health facilities posed a significant challenge in delivering safe emergency obstetric care at FRUs. To address this gap, there was a critical need to enhance the Life Saving Anaesthesia Skills (LSAS) of MBBS doctors, empowering them to manage anaesthesia effectively during emergency obstetric cases.

The LSAS training program was launched in 2013 aimed to enhance the capabilities of MBBS doctors, enabling them to promptly recognize and manage anaesthesia-related emergencies, implement crisis resource management principles, and administer safe anaesthesia during complex obstetric procedures. By bolstering the LSAS competencies of general practitioners, the program sought to alleviate the scarcity of specialized cadre in remote areas, thereby enhancing access to vital anaesthesia services and improving maternal and neonatal health outcomes. Recognizing the dynamic nature of medical practices and protocols, the LSAS curriculum has undergone a rigorous revision and update. This process involved extensive consultations with experts to ensure that the program effectively builds the capacity of MBBS doctors by enhancing their knowledge and skills in accordance with the latest evidence-based practices and protocols in obstetric anaesthesia care.

With this I would like to extend my heartfelt gratitude to Ms. Punya Salila Srivastava, Secretary (H&FW), Ms. Aradhana Patnaik, AS&MD (NHM), and Ms. Meera Srivastava, JS (RCH), for their steadfast guidance and administrative support in developing the revised LSAS curriculum.

Special thanks to the technical resource group members from esteemed medical colleges across India: Dr R K Batra, Former Professor & HOD, Department of Anaesthesiology, AIIMS, Dr Dhiraj Bhandari from MGIMS Wardha, Dr Mritunjay from AIIMS New Delhi, Dr Amita Sahoo from KDAH Mumbai and Dr Sandeep Mishra from JIPMER for their meticulous work in incorporating the latest technical updates and framing the LSAS curriculum with a proper blend of knowledge and skills.



The contributions of NHSRC, particularly Major General (Prof) Dr. Atul Kotwal, Executive Director, Dr. K. Madan Gopal, Advisor and Dr. Kalpana, Consultant Public Health Administration (PHA) Division, were pivotal in drafting the LSAS Curriculum.

The unwavering contributions of my esteemed colleagues, Dr. Anupama Prasad (Deputy Commissioner MH), Dr. Santosh Ojha, Dr. Bhumika Talwar, Mr. Vivek Singhal, Dr Vishal Dhiman, Dr. Tushar Purohit, Dr. Priyanka Sharma, Dr. Himangini Wadhawan, Dr. Jagdish Chhimpa, and Mr. Brahm Kumar Sharma, have been instrumental in drafting and finalizing the curriculum.

I am confident that the revised LSAS curriculum will serve as a valuable resource for States/UTs, improving the quality of LSAS training and facilitating the operationalization of First Referral Units (FRUs). Through these collective efforts, we are poised to enhance the delivery of Obstetric and New-born Care services across the nation.



(Dr Pawan Kumar)





## Maj Gen (Prof) Atul Kotwal, SM, VSM

MBBS, MD (PSM), PDF (Epidemiology),  
FRCP Edin, FAMS, FIPHA, FIAPSM  
Executive Director



## National Health Systems Resource Centre

राष्ट्रीय स्वास्थ्य प्रणाली संसाधन केंद्र  
Ministry of Health and Family Welfare  
Government of India



### MESSAGE

Providing comprehensive Emergency Obstetric and Newborn Care services is a widely recognized strategy for saving the lives of mothers and newborns. To achieve this, Government of India envisages that all the first referral units (FRUs) should be operationalized as 24-hour delivery centers with availability of basic and emergency obstetric and newborn services. However, the availability of skilled human resources remains one of the key requirements for operationalizing the identified FRUs in the country.

To address this, the 10<sup>th</sup>-Five Year plan's expert group's recommendations in 2003 led to the launch of training programs for MBBS doctors in Life Saving Anesthesia Skills (LSAS). The successful pilot of the programs in two states paved the way for its implementation across the entire nation in 2009. However, a review of the LSAS program indicated the need to revise the curriculum and make it more skill-based. To strengthen the program further, the course curriculum has been revised by MOHFW with support from National experts, development partners, and NHSRC. The new curriculum has incorporated the latest technical evidence and strategies to enhance the LSAS services. The duration of the training period has now been increased from 18 to 24 weeks, with an enhanced focus on the practical part for skill development.

India is already on a positive trajectory with remarkable progress in reducing maternal and child mortality over the last few years. Now, the effective dissemination of this new curriculum will significantly improve Emergency Obstetric Care Services and help us in achieving the desired SDG target ahead of time. I look forward to the States and training institutions utilizing this updated curriculum for effectively operationalizing their FRUs, thus ensuring the provision of Comprehensive Obstetric Care, which will significantly improve maternal and newborn care in India.

I want to thank all the experts who contributed to framing the revised curriculum for lending their expertise and dedication, which will eventually improve the emergency obstetric care services including anesthesia care and help reach the SDG target ahead of time.

  
Maj Gen (Prof) Atul Kotwal



# LIST OF CONTRIBUTORS

MINISTRY OF HEALTH & FAMILY WELFARE	
1.	Shri Apurva Chandra, Secretary (Health and Family Welfare)
2.	Ms. Aradhana Patnaik -AS&MD, NHM
3.	Ms. Meera Srivastava, JS (RCH)
4.	Dr. Pawan Kumar, Additional Commissioner, In-charge (MH & Immunization)
5.	Dr. Anupama Prasad, Deputy Commissioner, MH
6.	Dr Sumita Ghosh, Former -Additional Commissioner (Child Health)
7.	Dr. Padmini Kashyap, Former-Deputy Commissioner, MH
8.	Dr Dinesh Baswal, Former-Deputy Commissioner (MH), MoHFW
9.	Dr Aashima Bhatnagar, Deputy Secretary (NUHM)
10.	Dr. Santosh Ojha, Lead Consultant, MH division
11.	Mr Vivek Singhal, Lead Consultant, MH division
12.	Dr Tushar Purohit, Senior Technical Officer MH division
13.	Dr Priyanka Sharma, Consultant Midwifery MH division
14.	Dr Himangini Wadhawan, Consultant Midwifery MH division
15.	Dr Jagdish Chhimpa, Consultant Midwifery MH division
16.	Mr Brahm Sharma, M&E Consultant Midwifery MH division

NATIONAL HEALTH SYSTEMS RESOURCE CENTER	
1.	Maj Gen (Prof) Atul Kotwal, Executive Director
2.	Dr K Madan Gopal, Advisor, Public Health Administration (PHA) Division
3.	Mr. Prasanth KS, Senior Consultant, PHA Division
4.	Dr. Kalpana Pawalia, Consultant, PHA Division

INSTITUTIONAL EXPERTS	
1.	Dr R K Batra (Chairperson), Former HOD Anaesthesia, AIIMS, New Delhi
2.	Dr. B.S. Garg, Director, MGIMS, Sewagram, Wardha
3.	Dr Dinesh Baswal, Former DC (I/C) , MH , MoHFW
4.	Dr Sumita Ghosh (Member Secretary) , Former DC, MH, MoHFW
5.	Dr Himanshu Bhushan , Former Advisor , PHA , NHSRC
6.	Dr. Dhiraj Bhandari, Professor, Department of Anaesthesiology, MGIMS, Wardha



7.	Dr Sandeep Mishra, Additional Professor, Department of Anaesthesiology and Critical Care, JIPMER
8.	Dr Mritunjay Kumar, Associate Professor Anaesthesiology, AIIMS New Delhi
9.	Dr Amita Sahoo, Consultant Anaesthesiology, KDAH Mumbai
10.	Dr Ramchandraiah, Prof & HOD, Bangalore Medical College
11.	Dr Prashant Gupta, Associate Professor, Department of Microbiology, KGMU
12.	Dr. Sushma Nangia, Professor & Head, Department of Neonatology, LHMC, Delhi
13.	Dr Umesh Kumar Bhadani, HoD Department of Anaesthesiology, AIIMS Patna
14.	Dr Pradeep Kumar Bhatia, HoD, Department of Anaesthesiology, AIIMS Jodhpur
15.	Dr Sukdev Nayak, HoD, Department of Anaesthesiology, AIIMS Bhubhaneshwar
16.	Dr G P Singh, Prof, Department of Anaesthesiology, KGMU , Lucknow
17.	Prof G D Puri, HOD, Anaesthesiology, PGI Chandigarh
18.	Dr. Shrishti Goel, Assistant Professor, Department of Neonatology, LHMC, Delhi
19.	Dr Jaya Lalwani, Professor, Department of Anaesthesia, Raipur Medical College
20.	Dr. Harish Challani, Additional DGHS & Professor, Department of Paediatrics, VMMC & Safdarjung Hospital, Delhi
21.	Dr Yamini Serwal, CMO, Safdarjung Hospital
22.	Dr. Sukdev Nayak, Professor & Head, Department of Anaesthesiology, AIIMS, Bhubaneswar
23.	Dr. Sritam Swaroop Sena, Assistant Professor, Department of Anaesthesiology, AIIMS, Bhubaneswar
24.	Dr. Pradeep Bhatia, Professor & Head, Department of Anaesthesiology, AIIMS, Jodhpur
25.	Dr. Umesh Kumar Bhadani, Professor & Head, Department of Anaesthesiology, AIIMS, Patna
26.	Dr. R Rajendran, Senior Consultant (Anaesthesia), Apollo Speciality Hospital, Chennai, Formerly Prof of Anaesthesia, Madra Medical College and Chief Anaesthetist , Institute of O&G at Egmore, Chennai
27.	Dr. Raghvendra Rao, Professor & Head, Department of Anaesthesiology, Bangalore Medical College
28.	Dr. Dipika Choudhary, Head, Department of Anaesthesiology, Guwahati Medical College
29.	Dr. Manjula Sarkar, Professor & Head, Department of Anaesthesiology, KEM, Mumbai
30.	Dr. GP Singh, Professor & Head, Department of Anaesthesiology, KGMU, Lucknow
31.	Dr. A M Hashia, Professor, Department of Anaesthesiology, MM Medical College, Solan (HP)
32.	Dr. Ashok Kumar, Professor & Head, Department of Anaesthesiology, NMCH, Patna
33.	Dr. Debashish Swain, Associate Professor, Department of Anaesthesiology, Odisha
34.	Dr. G.D. Puri, Head, Department of Anaesthesiology, PGIMER Chandigarh
35.	Dr A M Hasia, Prof. Anaesthesia Maharishi Markandeshwar Medical College and Hospital, Solan, HP
36.	Dr Raghavendra Rao RS, HOD Anaesthesiology, Bangalore Medical College
37.	Dr. Shiv Lal Soni, Assistant Professor, PGIMER, Chandigarh
38.	Dr. Savita Saini, Professor & Head, Department of Anaesthesiology PGI, Rohtak, Haryana
39.	Dr. MK Sinha, Director, RK Care Hospital
40.	Dr. Rajesh Khanna, Professor, Department of Anaesthesiology, RIMS, Ranchi
41.	Dr. Usha Swalka, Head, Department of Anaesthesiology, RIMS, Ranchi
42.	Dr. Bhartendu Thakur, Surgeon, SKMCH Muzzafarpur, Bihar

<b>43.</b>	Dr. Sarla Hooda, Head, Department of Anaesthesiology, SGT Medical College, Gurgaon
<b>44.</b>	Dr Neeraj Bhardwaj, Consultant Anaesthesia, President BAOIA , MFT UK
<b>STATE &amp; DISTRICT EXPERTS</b>	
<b>1.</b>	Dr. K Zainam, MH Consultant, NHM, Assam
<b>2.</b>	Dr. Venkata Ramana Kumari Sali, DWH, Vishakhapatnam
<b>3.</b>	Dr. S Sirkar, CMO, Sadar Hospital, Karihar, Bihar
<b>4.</b>	Dr. Razi Neeraj, Medical Officer, Sadar Hospital, Siwan, Bihar
<b>5.</b>	Dr. Amita Kashyap, Director, SIHFW, Jaipur, Rajasthan
<b>6.</b>	Mr. Sanjay Saxena, Registrar, SIHFW, Jaipur, Rajasthan
<b>7.</b>	Dr. Anurodh Tiwari, Consultant, MH, Rajasthan
<b>8.</b>	Dr. Dinesh, Medical Officer, Rajasthan
<b>9.</b>	Dr. Ashwini Kr. Singh, Consultant, MH, SPMU, NHM
<b>10.</b>	Dr. Tarun Choudhary, Project Director, Maternal Health, NHM, Rajasthan
<b>11.</b>	Dr. D Sudhakaran, Professor & Chief Anaesthesiology, RSRM Lying-in Hospital, SMC, Tamil Nadu
<b>12.</b>	Dr Sauredrajit Sircar, CMO, District Hospital, Kaithar, Bihar
<b>13.</b>	Dr. GM Premkumar, Medical Officer, GPHC, Kattampoondi, Tamil Nadu
<b>14.</b>	Dr. M.F. Mohd. Rifan, Medical Officer, PHC, Karungulam, Tamil Nadu
<b>15.</b>	Dr. V Manikandan, Medical Officer, PHC, Tamil Nadu
<b>16.</b>	Prof. Dr. ML Bhatt, Ex Vice-Chancellor, KGMU, Lucknow
<b>17.</b>	Dr Sapna Das, Ex-GM, Maternal Health, Uttar Pradesh

<b>DEVELOPMENT PARTNERS</b>	
<b>1.</b>	Dr Bhumika Talwar, Maternal Health & Midwifery Specialist, UNFPA
<b>2.</b>	Dr Rashmi Asif, C 3
<b>3.</b>	Dr. Rajani Ved, Country Director BMGF
<b>4.</b>	Dr. Manisha Malhotra, Senior Advisor, JHPIEGO
<b>5.</b>	Dr. Sunita Dhamija, Advisor, Clinical Services and Training, JHPIEGO
<b>6.</b>	Dr. Renu Shrivastava Goel, Ex-MNCH Advisor, JHPIEGO- NIPI
<b>7.</b>	Dr. Bulbul Sood, Ex country Director, JHPIEGO
<b>8.</b>	Dr. Kirti Sharad Iyengar, Ex Programme Specialist, UNFPA
<b>9.</b>	Dr. Apurva Chaturvedi, Ex Health Officer, UNICEF
<b>10.</b>	Dr Deepak Sinha, UNICEF
<b>11.</b>	Dr Kanupriya Singhal, Health Specialist, UNICEF Uttar Pradesh
<b>12.</b>	Dr. Ram Chahar, Ex National Professional Officer (Maternal and Reproductive Health), WHO



# TABLE OF CONTENT

(24 week curriculum schedule)

Week	Module name	Chapter	Chapter name FINAL	Page No
WEEK 1	Introduction to course and Anesthesia	1.	Introduction to course	02
		2.	Introduction to Anaesthesia	07
		3.	Medico-legal aspect of the course	24
		4.	Operation room management	40
WEEK 2	Anatomy Physiology & Pre anesthesia checkup	5.	Anatomy including Airway Anatomy relevant to Anaesthesia	50
		6.	Physiological changes during pregnancy	55
		7.	Pre-Anaesthesia Checkup	78
WEEK 3	Airway Management	8.	Airway management I	86
		9.	Airway gadgets II	
		10.	Airway Gadgets III	
		11.	Assessment and management of airway including difficult airway.	90
WEEK 4	Oxygen therapy, spinal and general anesthesia.	12.	Oxygen Therapy	112
		13.	Physiology of spinal anesthesia	121
		14.	Spinal Anesthesia	
		15.	General Anesthesia	
WEEK 5	Anesthesia machine, monitoring.	16.	Anesthesia machine	150
		17.	Checklist of machine	172
		18.	Anaesthesia monitoring system	181
		19.	Premedication	185

Week	Module name	Chapter	Chapter name FINAL	Page No
WEEK 6	Premedication, fluids, blood and CPR	20.	Cardio pulmonary resuscitation including obstetric CPR	194
		21.	Neonatal CPR	221
		22.	Fluid therapy & electrolytes	230
		23.	Blood transfusion, Acid-base balance	250
WEEK 7	PACU & Complications	24.	Pain relief	264
		25.	Anesthesia record keeping	271
		26.	PACU functioning	284
		27.	Complications in perioperative setup: I	289
28.	Complications in perioperative setup: II			
WEEK 8	Systemic diseases- Part 1	29.	Hypertensive disorder of pregnancy	314
		30.	Asthma and pregnancy	324
		31.	Diabetes mellitus & pregnancy	329
		32.	Anemia & pregnancy	335
		33.	Pregnancy & renal disease	341
Week 9	Systemic disease-Part 2	34.	Hemorrhagic disorder and pregnancy	348
		35.	Cardiac disease and pregnancy	359
		36.	Liver disease and pregnancy	367
		37.	Trauma and pregnancy	372
		38.	Opioid and non opioid analgesia	382
WEEK 10	Pharmacology- 1 Anesthesia	39.	IV anesthesia induction agents	388
		40.	Inhalation anesthesia agents	394
		41.	Neuromuscular blocking & reagents	401
		42.	Local anesthesia drugs	408
WEEK 11	Pharmacology -2 Emergency drugs	43.	Emergency and Cardiac drugs	416
		44.	Sympathomimetic drugs	430
		45.	Respiratory drugs	439
WEEK 12	Referral, Transport & Communication skills	46.	Communication skills	446
		47.	Referral guidelines	
		48.	Transport of critically ill patients	451
		49.	Fetal distress: Anesthesiologist role	457
		50.	Infection control practices in OT	461

Week	Module name	Chapter	Chapter name FINAL	Page No
WEEK 13, 14	Revision of any chapters as desired by students and as deemed essential by trainers.			481
WEEK 15 & 16	Revision of practical skills as desired by students and as deemed essential by trainees on mannequins.			
WEEK 17, 18, 19 & 20	DH Posting (4weeks) All skills assist/perform day and night posting by rotation			
WEEK 21 to 24	Revision of any chapter & practical skills as desired by students and as deemed essential by trainees at Medical College. Certificate Distribution and completion of essential formalities.			

(This is as per the CEmONC and LSAS operational Guidelines)

---





# Week 1 - Module

## Introduction to the Course and Anaesthesia



# 01

## Introduction to the Course

---

All pregnant women are at risk of Obstetric.

Complications life threatening complications.

Maternal mortality Ratio **97 per 1,00,000 live births (2019-21).**



**During Labour & Delivery**

### **MAIN CAUSES OF MATERNAL MORTALITY ARE THE COMPLICATIONS RESULTING FROM:**

- Haemorrhage
- Unsafe abortions
- Eclampsia
- Sepsis
- Obstructed labour

### **DEATH FROM THESE CAUSES ARE PREVENTABLE WITH:**

- Provision of good quality Ante-natal, Natal & Post natal care.
- Safe institutional delivery services
- Timely referral
- Provision of Emergency Obstetric Care

Under the RCH programme, a number of initiatives have been taken to strengthen emergency obstetric care services at the First Referral Units.

Despite this, the actual operationalisation of FRUs is suffering due to lack of specialist/ trained manpower, particularly in the field of anaesthesia.

Efforts were made to hire the services of anaesthetists from a private sector at a payment of ₹1000/= per case during RCH – I (1997-98). But it has not been possible to get their services, particularly in sub-district areas due to acute lack of anaesthetists.

The 10th five year plan working group on Health of women and children has observed that “shortage of anaesthetist is perhaps the single most important cause of inadequacy of emergency care in Govt. hospitals particularly in rural areas.”

## COMMITTEE RECOMMENDED THAT:

- Post of specialists in CHCs should be filled on priority.
- Reorientation, skill up gradation & redeploying existing manpower should be the method used to fill critical gaps.

With this in view, the Govt. of India formed a core group of experts in June 2002 with the Professor & Head Anaesthesia, casualty & emergency Services, AIIMS, New Delhi as chairman & DDG as the convener. The group consists as experts in Anaesthesia with representation from the National Institute of H. & F. W, WHO and EC (European Commission). They developed a curriculum and course for M.B.B.S. doctors to train in Anaesthesia for Emergency Obstetric Care - Life Saving Anaesthetic Skills for Emergency Obstetric Care. The group also considered NMC curriculum on anaesthesia during internship of MBBS Doctors.

Consequently the Lifesaving Anesthesia Skills (LSAS) training program (an 18 week program ) was rolled out in 2003 to train MBBS doctors in providing comprehensive anesthetic obstetric care services. The program was initiated to overcome shortage of specialist manpower & operationalize First Referral Units (FRUs). The doctors trained in LSAS were able to provide with necessary skills & competencies to manage the cases requiring lifesaving emergency obstetric care at the FRUs.

An independent evaluation of the program was conducted on the behest of MoHFW in the following years. The evaluation identified attributes like irrational posting, lack of complementary facilities like OT/HDU, Anesthetists/LSAS trained doctor, Blood bank/Blood storage unit for providing desired services. The quality of training at Medical colleges was excellent but the same at the DH level wasn't adequate. Based on the inputs received from the evaluation an expert group was formed by the ministry under the Chairpersonship of Dr. R K Batra, then HOD, Anesthesia Department, AIIMS New Delhi along with experts from Center of Excellences like AIIMS, PGI, MGIMS, Sevagram, JIPMER. Deliberations were held on latest evidence based protocols & guidelines for firming up the draft curriculum.

The curriculum underwent significant revisions following expert consultations to incorporate the latest technical evidence and strategies to enhance LSAS services. The curriculum has now been revised and includes the latest technical updates and protocols which have evolved over all these years. The duration of the the training period has now been increased from 18 to 24 weeks, focussing on the practocal part as well.

## AIM & OBJECTIVES:

To provide selected MBBS doctors with necessary skills & competencies to manage the cases requiring life saving emergency obstetric care at the FRUs.

## KNOWLEDGE BASED OBJECTIVES:

### Trainees are expected to know after the training:

- Anatomy of upper airway & spine, use of the knowledge while performing endotracheal intubation, spinal & epidural. How to reassess and retry the difficulties if it occurs.  
Anatomical difference between pregnant and non-pregnant patient and physiological changes of pregnancy.
- Effects of anaesthetics on the foetus, benefits and risks of anaesthetic technique to the mother which drugs to be used in which anaesthetic situation, how to decide the dosage and route of

administration, how to judge the effects and complications of these drugs and how to manage their complications.

- Basic working principle of anaesthesia machine, safety mechanisms of the machine, ways to check the integrity and functions of the various components of the machine before using it.
- History taking, examination and Operation theatre preparation management and how to make a decision regarding shifting of the patient to referral centre.
- Guidelines regarding administration of general or regional anesthesia for emergency obstetric procedure & important considerations to be kept in mind while anaesthetizing a patient for emergency caesarean section.
- Various systemic diseases that may be associated with pregnancy, clinical presentation, diagnosis and emergency.
- Various types of trauma that a pregnant lady may commonly sustain, how the management differ from that of a non-pregnant women and how to resuscitate.
- Airway adjuncts and their usage, technique of intubation and difficult intubation drill.
- Legal aspect of the medical profession.

## **SKILL BASED OBJECTIVES:**

### **Trainees are expected to acquire skills in:**

- Pre-anaesthetic examination of patient - History and general physical systemic examination, interpretation of test results, deciding about the type of Anaesthesia which can be best for the Patient, Pre-anaesthetic preparation (Physical, Psychological, Legal aspects like Consent, Drugs etc.)
- Use of various types of anaesthetic and support equipment required at FRU level, preparation of equipment before surgery and their maintenance and upkeep after surgery.
- Resuscitation of new born & mother if required.
- Perform laryngoscopy & endotracheal Intubation.
- Administration of G.A. & R.A. & their maintenance.

## **SYLLABUS :**

The entire syllabus for LSAS Course consist of theory and practical teaching spread over fourteen weeks into various modules and chapters which aims at acquiring the above mentioned skills by trainee.

### **Assessment and evaluation of the Trainees:**

The over-all assessment of trainees will be in three Tiers:

#### **Tier I Internal Assessment:**

By trainers at the medical college. This will be in two parts (Ia and Ib) of 100 marks each with equal weightage to theory and practicals (50% marks for each). These exams will contribute 20% to the final assessment.

The syllabus for Tier 1a exam will consist of Week 1 to Week 6 of the curriculum and the assessment should be held between Weeks 6 to 8. The syllabus for Tier 1b exam will consist of Week 7 to Week 12 of the curriculum and the assessment should be held between Weeks 12 to 14.

### Tier II Internal Assessment:

By the HOD Anaesthesia at the State Medical College. This will comprise of 100 marks and the weightage for theory and practical will be 20% and 80% respectively. This assessment will contribute 20% towards the final assessment and should be held in Week 16.

### Tier III Final assessment:

Will be held at the State Medical College/ Certifying Institute and will be of 200 marks with equal weightage of 100 marks for both theory and practical. Of note, out of the 100 marks in theory here, 10 marks will be for the workbook, 10 marks for the logbook and 80 marks for the theory question paper. The Tier III exam will contribute 60% towards the final assessment and will be conducted by 3-4 examiners (to include one or two internal and two external experts). Tier III should be conducted in Weeks 23-24.

The structure of the exams is presented in the table below:

No.	Tier	Syllabus	Exam Time	Theory marks	Practical marks	Weightage
1	Tier Ia	Week 1-6	Between weeks 6-8	50	50	20
2	Tier Ib	Week 7-12	Between weeks 12-14	50	50	
3	Tier II	Week 16	Between weeks 16-18	20	80	20
4	Tier III	Full syllabus	Between Weeks 23-24	100*	100	60

\*(Of the 100 marks here, 10 marks are for workbook, 10 for logbook and 80 for the theory paper)

The pass percentage of the exam is 70% (in theory and practical combined).

If a candidate does not pass in the first attempt, they are allowed a second attempt with the next batch; a re-orientation for 4-6 weeks before this exam should be arranged by the candidate in conjunction with the lead trainer at the training site.

## SELF CHECK QUESTIONS:





# 02

## Introduction to Anaesthesia

---

### INTRODUCTION

We will discuss in this module anatomy as relevant in context of your role as the anesthesia care provider in emergency obstetric situations. It gives an overall idea about certain anatomical facts, which you should have at the back of your mind while proceeding to provide anesthesia. Do keep any standard textbook of anatomy for ready reference.

### OBJECTIVES

After going through this module you should be able to:

- Describe anatomy of upper airway and spine.
- The knowledge while performing endotracheal intubation, spinal and epidural blocks.
- Discuss how to reassess and retry if encountering difficulty during the above procedures.
- To describe the anatomical differences between pregnant and non-pregnant patient.

### CONTENTS

#### Anatomy of larynx

The larynx, also known as the voice box, routes the food and air to their proper destination. The larynx is made up of eight hyaline cartilages and a flap of elastic cartilage, the epiglottis.

The epiglottis' job is to prevent food from entering the upper opening of the larynx, and traveling down the trachea. Breathing opens the epiglottis and allows free passage of air to the lungs. The larynx is pulled in an upward direction while swallowing, causing the epiglottis to "tip" and close over the opening of the larynx. When the epiglottis is closed, it directs food to be pushed down the esophagus. If something besides air enters the larynx, a cough occurs. A coughs' purpose is to repel any foreign substance, besides air, from entering the trachea. The mucous membrane of the larynx forms the vocal folds. The vocal folds vibrate by the expelled air. This vibration allows human's the ability of speech. The glottis is the thin passageway between the vocal folds.

The largest of the hyaline cartilages is the thyroid cartilage. The thyroid cartilage, also called the Adams apple, protrudes anteriorly. Larynx's vertical extent corresponds to the fourth and sixth cervical vertebrae, but it is placed somewhat higher in the females and also during childhood.



	Male	Female
Length	44 mm.	36 mm.
Transverse diameter	43 mm.	41 mm.
Antero-posterior diameter	36 mm.	26 mm.
Circumference	136 mm.	112 mm.

## INNERVATION

The sensory innervation of the airway is divided among three areas:

- The nose and nasopharynx are innervated by maxillary branches of the trigeminal nerve.
- The posterior one third of the tongue and oropharynx are innervated by branches of the glossopharyngeal nerve. This nerve exits the skull through the jugular foramen and travels in the carotid sheath.
- The larynx and trachea are innervated by branches of the vagus nerve. The superior laryngeal nerve carries sensation from the base of the tongue and the inferior epiglottis to the vocal cords. The recurrent laryngeal nerve carries sensation distal to the vocal cords.
- The superior laryngeal nerve travels inferior to the greater cornu of the hyoid bone and divides into internal and external branches. The internal branch pierces the thyrohyoid membrane with laryngeal branch of the superior thyroid artery. The muscles of the larynx are supplied by branches of the vagus nerve. The cricothyroid muscle is supplied by the external branch of the superior laryngeal nerve. All of the other intrinsic muscles of the larynx are supplied by the inferior laryngeal nerve, a continuation of the recurrent laryngeal nerve.

Airway assessment by physical examination:

### Oral Cavity

- Mouth opening: note symmetry and extent of opening (3 finger breadths optimal).
- Dentition: ascertain the presence of loose, cracked, or missing teeth, dental prostheses and co-existing dental abnormalities.
- Macroglossia: will increase difficulty of intubation.

### Neck

- Anterior mandibular space: evaluated by asking the supine patient to maximally extend the head and measuring the distance between the hyoid bone and the inside of the mentum or between the notch of the thyroid cartilage to the mentum. An inadequate mandibular space is associated with a hyomental distance of 6cm or a thyromental distance of 6.5cm.
- Cervical spine mobility (Atlantooccipital joint extension): 80° extension is normal at the atlantooccipital joint. Decreases in extension are associated with increased difficulty of intubation. Evaluate for presence of a healed or patent tracheostomy stoma, prior surgeries or pathology of the head and neck (laryngeal cancer).

## Predictors of difficult intubation

### Anatomic variations

Micrognathia, prognathism, large tongue, arched palate, short neck, prominent upper incisors, buckteeth, decreased jaw movement, receding mandible or anterior larynx, short stout neck.

### Mallampati classification

The Mallampati classification relates tongue size to pharyngeal cavity. Test is performed with the patient in the sitting position, the head held in a neutral position, the mouth wide open, and the tongue protruding to the maximum. The subsequent classification is assigned based upon the pharyngeal structures that are visible.

### Mallampati classification (classification of tongue size vs pharynx)

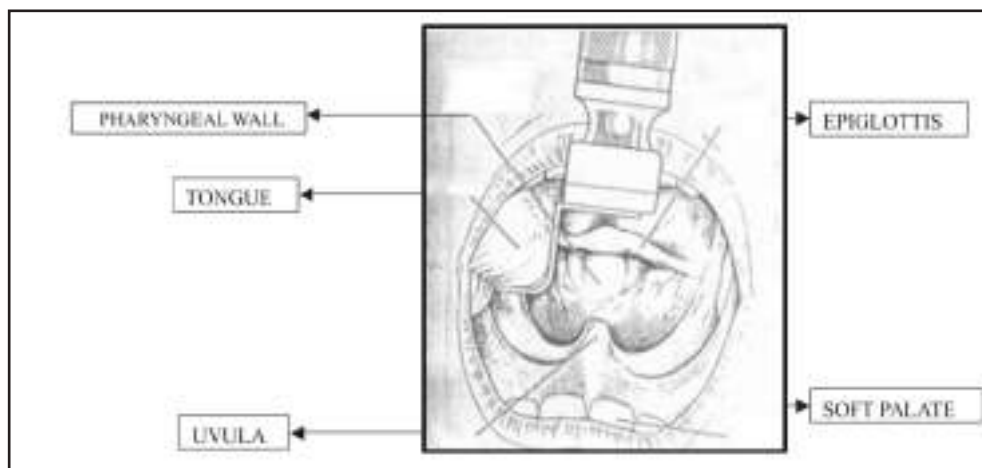
- Class 1: able to visualize the soft palate, fauces, uvula, anterior and posterior tonsillar pillars.
- Class 2: able to visualize the soft palate, fauces and uvula. The anterior and posterior tonsillar pillars are hidden by the tongue.
- Class 3: only the soft palate and base of uvula are visible
- Class 4: only the soft palate can be seen (no uvula seen)

The classification assigned by the clinician may vary if the patient is in the supine position instead of sitting. If the patients phonate, this falsely improves the view. If the patient arches his or her tongue, the uvula is falsely obscured. A class 1 view suggests ease of intubation and correlates with a laryngoscopic view grade-1 in 99 to 100% of the cases. Beware of the intermediate classes, which may result in all degrees of difficulty in laryngoscopic visualization.

### Grades of laryngoscopic view (Cormack & Lehane)

- Grade 1: full view of the entire glottic opening.
- Grade 2: posterior portion of the glottic opening is visible.
- Grade 3: only tip of epiglottis is visible.
- Grade 4: only soft palate is visible (no part of glottis or epiglottis visible)

Grade II or III laryngoscopic views are relatively common and occur in 1% to 18% of surgical patients. The Grade III view occurs in about 1-4% of patients. A severe grade III or grade IV view with failed endotracheal intubation occurs in 0.05 to 0.35% of patients. It may be helpful for the subsequent anesthesiologist if you record the grade of laryngoscopic view achieved along with the patient position and the technique used.



## CHANGES IN THE RESPIRATORY SYSTEM DURING PREGNANCY

Hormonal changes to the mucosal vasculature of the respiratory tract lead to capillary engorgement and swelling of the lining in the nose, oropharynx, larynx, and trachea. Symptoms of nasal congestion, voice change and upper respiratory tract infection may prevail throughout gestation. These symptoms can be exacerbated by fluid overload or oedema associated with pregnancy induced hypertension (PIH) or pre-eclampsia. In such cases, manipulation of the airway can result in profuse bleeding from the nose or oropharynx: endotracheal intubation can be difficult: and only a smaller than usual endotracheal tube may fit through the larynx. Airway resistance is reduced; probably due to the progesterone mediated relaxation of the bronchial musculature. So the pregnant airway is different from normal airway.

Suctioning of oropharynx, insertion of airways, and laryngoscopy may further lead to edema and bleeding. The false cords may be swollen; hence a small cuffed endotracheal tube (6.5-

7.0mm) is recommended for use when trachea is intubated. Repeated attempts at laryngoscopy during management of a difficult airway must be minimized to prevent occurrence of airway edema.

The problem of difficult laryngoscopy is often encountered at intubation. This is largely due to the engorged breast that makes the insertion of handle of laryngoscope difficult. This can be solved by using a shorter handle, inserting the blade first and then attaching the handle, using a pillow under the shoulder, and in some cases by separating the breast laterally by using adhesive tapes.

## ANATOMY FOR SPINAL ANAESTHESIA

The spinal cord usually ends at the level of L-2 in adults and L-3 in children. Dural puncture above these levels is associated with a slight risk of damaging the spinal cord and is best avoided. An important landmark to remember is that a line joining the top of the iliac crests is at L-4 spine or L4-5 space. Remember the structures that the needle will pierce before reaching the CSF.

The skin: It is wise to inject a small dose of local anesthetic intradermally before inserting the spinal needle.

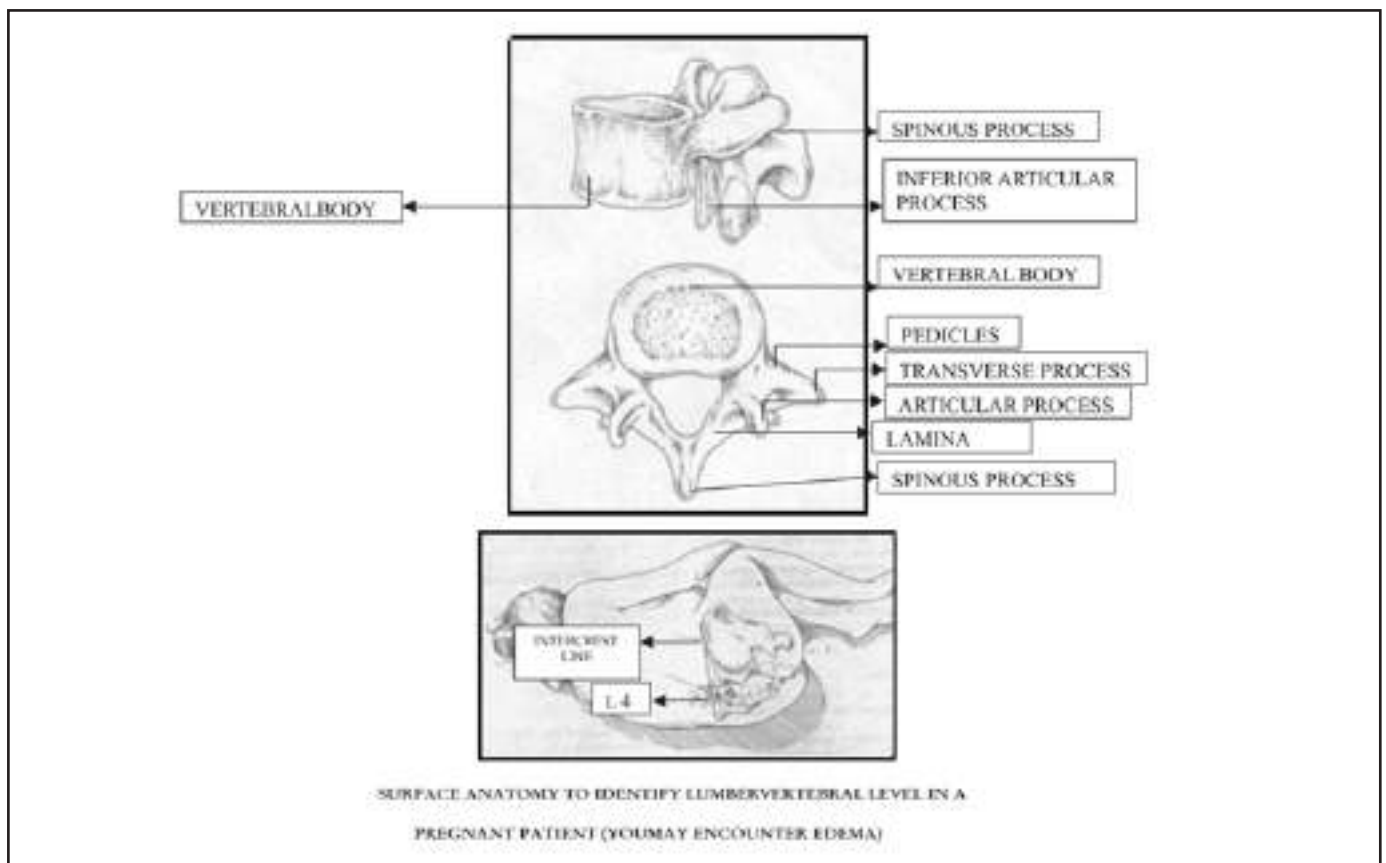
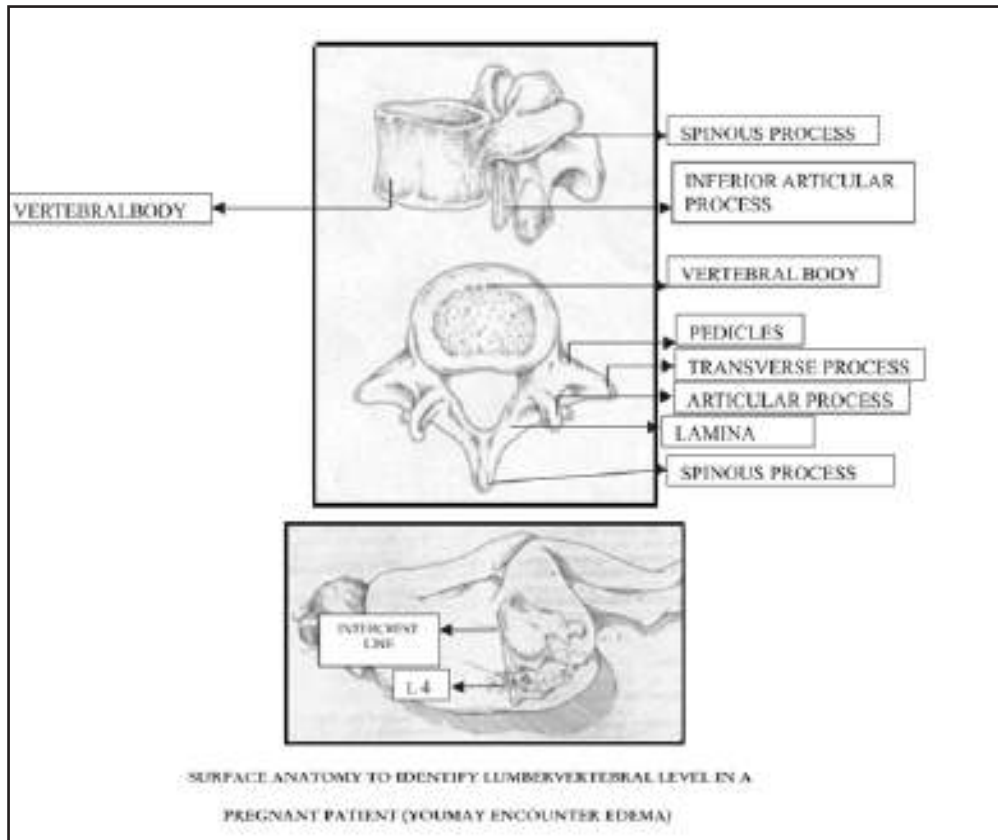
Subcutaneous fat: This is of variable thickness. Identifying the intervertebral spaces is far easier in thin patients.

Supraspinous ligament: Joins the tips of the spinous processes together.

Interspinous ligament: Is a thin flat band of ligament running between the spinous processes.

Ligamentum flavum: Is quite thick, up to about 1cm in the midline and is mostly composed of elastic tissue. It runs vertically from lamina to lamina. When the needle is within this ligament it will feel gripped and a distinct "give" can often be felt as it passes through this into the epidural space. The epidural space contains fat and blood vessels. If blood comes out of the spinal needle instead of CSF when the stylet is removed, it is likely that an epidural vein has been punctured. The needle should simply be advanced a little further. A similar 'give' may be felt when the needle is advanced a short distance further and pierces the dural sac.

Subarachnoid space: This contains the spinal cord and nerve roots surrounded by CSF. An injection of local anesthetic will mix with the CSF and rapidly block the nerve roots with which it comes in contact.



## POSITIONING THE PATIENT FOR LUMBAR PUNCTURE

Lumbar puncture is most easily performed when there is maximum flexion of the lumbar spine. This can best be achieved by sitting on the operating table and keeping the feet on a stool. The patients then rest their forearms on their thighs, they can maintain a stable and comfortable position. Alternatively, the procedure can be performed with the patient lying on their side with their hips and knees maximally flexed. An assistant may help to maintain the patient in a comfortable curled position. The sitting position is preferable in the obese whereas the lateral is better for uncooperative or sedated patients. The anaesthetist can either sit or kneel whilst performing the block.

## ANATOMY OF THE EPIDURAL SPACE

The epidural space is that part of the vertebral canal not occupied by the duramater and its contents. It is a potential space that lies between the dura and the periosteum lining the inside of the vertebral canal. It extends from the foramen magnum to the sacral hiatus. The anterior and posterior nerve roots in their dural covering pass across this potential space to unite in the inter-vertebral foramen to form segmental nerves. The anterior border consists of the posterior longitudinal ligament covering the vertebral bodies, and the inter-vertebral discs. Laterally, the epidural space is bordered by the periosteum of the vertebral pedicles, and the inter-vertebral foraminae. Posteriorly, the bordering structures are the periosteum of the anterior surface of the laminae and articular processes and their connecting ligaments and the inter-laminar spaces filled by the ligamentum flavum. The space contains venous plexuses and fatty tissue, which is continuous with fat in the para-vertebral space.

## SALIENT POINTS TO REMEMBER

- Position for intubation is extension at atlanto-occipital joint and flexion of cervical spine.
- Pre-operative airway assessment is essential
- In pregnancy, you are likely to encounter an edematous airway, especially in presence of pregnancy induced hypertension - use smaller ET tube.
- It is safe to give a spinal or epidural below L2 level, L2-L3 space or L3-L4 space.
- Due to vena caval compression by the gravid uterus, there is distension of the epidural venous plexus, increasing the chances of intravascular injection while attempting an epidural injection.

## CHECK YOUR PROGRESS:

1. What is the nerve supply of larynx?
2. The toughest structure you encounter in giving spinal is
  - a) Skin
  - b) Duramater
  - c) Ligamentum flavum
  - d) Supra spinous ligament
3. The extent of epidural space is from foramen magnum to.
4. Pregnant airway is more vascular than the normal airway. True/ False .
5. The Mallampati classification is done while a) the patient lies down – T/F, b) the patient protrudes the tongue – T/F.

## Further readings

- Snell's clinical anatomy
- Essential anatomy for anesthesia by Sue M. Black

## GENERAL ANAESTHESIA

### INTRODUCTION

State of General Anesthesia is defined as "Progressive reversible depression of nervous tissue". It can also be defined as "Controlled Production of unconsciousness". The term "anaesthesia" was coined by Sir Oliver Wendell Holmes ( – an American Physician, Poet and Essayist) in 1846. After hearing about the successful public demonstration of Ether Anesthesia by "W.T.G. Morton" on 16th of October 1846; Sir Oliver Wendell Holmes wrote to Morton that, "the state I

think be called as Anaesthesia".

There are four stages of Anaesthesia. These have been given by Guedel in 1951, hence this classification is known as "Guedel's classification". It is to be remembered that these stages can only be observed using volatile anaesthetic agents especially diethyl ether. The stages are as under :-

1. First stage – Stage of Analgesia.
2. Second stage – Stage of Excitement.or Delirium
3. Third stage – Stage of Surgical Anaesthesia.

Third stage is further subdivided into four planes:-

Viz, Plane i, ii, iii & iv.

4. Fourth stage – Stage of OVER DOSAGE./ MEDULLARY PARALYSIS

In today`s Anaesthesia practice of intravenous induction, these stages can no longer be observed.

GENERAL Anaesthesia is a triad having 3 basic components viz:

1. Narcosis - sleep
2. Analgesia – loss of pain sensation.
3. Relaxation – Skeletal muscle Relaxation.

In Regional Anesthesia there is profound Analgesia and skeletal muscle relaxation but the patient is conscious.

## CLASSIFICATION OF GENERAL ANAESTHETICS

General Anaesthetics are classified as:

### I. Intravenous Anaesthetic Agents:

These can further be subdivided into:-

- A. Barbiturates
- B. Non-barbiturates

## II. Inhalational Agents:

These can be further subdivided into :-

- A. Anaesthetic Gases
- B. Volatile Liquid

### I. Intravenous Anaesthetic Agents:

I. (A) Intravenous barbiturates are classified according to their chemical structure as under:-

1. Oxybarbiturates e.g. Pentobarbitone
2. Methylated Oxybarbiturates e.g. Methohexitone
3. Thiobarbiturates e.g. Thiopentone.

I. (B) Nonbarbiturate I/V anaesthetic agents. Examples:-

1. Propanidid (Epontol) – Not used nowadays.
2. Althesin (Steroid I/V Anaesthetic agent) – not used nowadays.
3. Etomidate – used occasionally.
4. Ketamine – produces Dissociative Anaesthesia.
5. Propofol – available as 1% solution.

## II. Inhalational Agents

II. (A) ANAESTHETIC GASES – Examples:-

1. NITROUS OXIDE –  $N_2O$  – COMMONLY USED.
2. CYCLOPROPANE -  $C_3H_6$
3. ETHYLENE -  $C_2H_4$
4. XENON – Xe

II (B) Volatile Anaesthetic Agents:-

1. CHLOROFORM –  $CHCl_3$
2. TRICHLOROETHYLENE –  $C_2HCl_3$
3. DIETHYL ETHER –  $(C_2H_5)_2O$  still available
4. ETHYL CHLORIDE –  $C_2H_5Cl$
5. Fluorinated Hydrocarbons:

These comprise group of volatile anaesthetic agents which are highly stable, non – inflammable and have a low toxicity.

Examples:-

1. Halothane (Fluothane) – Color code Red.
2. Methoxyflurane
3. Enflurane
4. Isoflurane – Color Code Purple
5. Fluroxene
6. Sevoflurane – color code Yellow.



Anaesthesiologist is a perioperative physician who evaluates and prepares the surgical patient in preoperative period, provides intra-operative anaesthetic care (whether general, regional or local anaesthesia), takes care of the patient in the postoperative period.

### PREOPERATIVE EVALUATION:

Preoperative evaluation of the surgical patient enhances the anaesthesiologists awareness of patients medical condition and facilitates the plan of intra and postoperative care. Routine surgical patients are evaluated as soon as their name is placed on the waiting list; while patient undergoing emergency operations should be evaluated as soon as practicable.

Pre-anaesthetic evaluation should include:-

1. Full History.
2. Clinical Examination.
3. Investigations.
4. Ordering for cross matching of blood.
5. Obtaining informed written consent.
6. Preparing the patient.

### History :

#### Quick Assessment of Patient:

Attention should be given to the following points in history.

1. Previous illness, operations and anesthetics. Complications of previous administration may be avoided on this occasion.
2. Significant drug therapy. E.g. Insulin, oral hypoglycemic agents, antihypertensives, digitalis, corticosteroids, anticoagulants, diuretics, etc. H/o drug allergies.
3. Symptoms referable to respiratory and cardiovascular systems.
4. Tendency to Vomiting.

#### Medical History:

##### For Respiratory Symptoms:

- Cough.
- Sputum production.
- Dyspnea.
- Wheezing.

##### For Cardiovascular Symptoms:

- Angina.
- Pedal edema.
- Orthopnoea.
- Previous myocardial infarction.
- Shortness of breath after climbing stairs.

If so, how many stairs? How fast?

### Anaesthetic History:

- Old anaesthesia records should be reviewed for ease of mask ventilation and direct laryngoscopy and size of endotracheal tube used.
- Perioperative complications such as adverse drug reaction, cardiorespiratory instability, prolonged emergence or re-intubation, ICU stay, elective ventilation.
- Patients should be asked for complaints: Postoperative nausea and vomiting, hoarseness, neurological deficits or any other specific warnings from previous anaesthesia provider describing prior anaesthetic problems.

### History of Last Intake of Food and Drink (NPO Status):

- Consider every pregnant woman as having full stomach.

### Past History of:

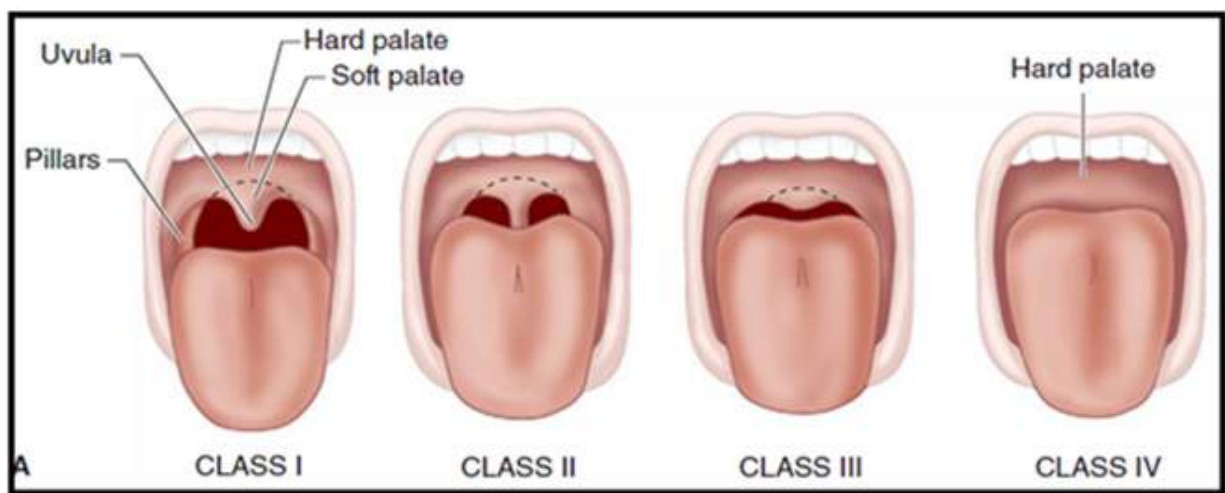
- Hepatitis.
- Diabetes.
- Asthma.
- Bronchitis.
- Tuberculosis.
- Bleeding problems.
- Other medical condition.

### Clinical Examination:

#### General Physical Examination:

- i. State of nutrition – malnutrition or obesity.
- ii. State of veins – I/V access – easy, or difficult.
- iii. Pulse & Blood Pressure.
- iv. Other findings e.g. oedema etc.
- v. Airway:-
  - a. **Mouth opening** – with mouth fully open, inter incisor gap is assessed. It is graded as :-
    - Grade I > 4 cm
    - Grade II < 4 cmInter Incissor distance < 4 cm may be associated with difficult intubation.
  - b. Presence of loose teeth, Crowns etc.
  - c. **Head and neck movements** – The head and neck movements are measured by full extension of head and neck and are graded as:-
    - Class I > 90°.
    - Class II 80 - 90°.
    - Class III < 80°.Class III is usually associated with difficult intubation.
  - d. Wide short neck – Normal neck body ratio is 1:13. Ratio >1:13 is taken as short neck. Wide short neck may be associated with difficult intubation.

- e. Thyromental distance – Patient sitting and head in sniffing position measurement along straight line from upper border of thyroid notch to lower border of mandibular mentum is taken. It is graded as:-
- Class I > 6.5 cm
  - Class II 6-6.5 cm
  - Class III < 6 cm
- Class III may be associated with difficult intubation.
- f. Mallampati scoring system – Patients with MP-I are easier to intubate than patients with MP-IV.



- vi. Examination of cardiovascular, respiratory system.
- vii. Examination of nervous system and spine.

#### Examination of Spine:

Presence of Obvious deformity, Condition of the Skin (Infection, Edema etc.).

#### Investigation:

Following investigations may be checked if patient has been already, investigated; otherwise these may be ordered:-

- i. Haemoglobin and blood group.
- ii. Complete urine examination.
- iii. Blood urea, serum creatinine.
- iv. Serum Electrolytes – Sodium and Potassium
- v. Blood Sugar – Fasting / Random.
- vi. 12 lead electrocardiogram.

In certain cases it may be desirable to seek the opinion of other specialists e.g. Physician, Cardiologist, Endocrinologist etc.

## ASSESSMENT OF PHYSICAL STATUS (P.S.)

American society of Anesthesiologists have classified patients into a number of grades according to their general condition and risk. These grades are as under :- (ASA GRADING)

1. A normal healthy patient.
2. A patient with mild systemic disease.
3. A patient with a severe systemic disease that limits activity, but is not incapacitating.
4. A patient with an incapacitating systemic disease that is a constant threat to life.
5. A moribund patient not expected to survive 24 hours with or without an operation.
6. Brain dead waiting for organ retrieval.

In emergency operation E should precede the number.

### Written Informed Consent:

- Discussing anesthetic plan, alternatives & potential complications of each technique in terms understandable to the patient.
- It should be documented whether the procedure was explained, understood and accepted by the patient.
- Discussion should be conducted in the patient's native language.
- Written forms should be available in patient's native language.
- Anesthesia provider's note: Preoperative anesthesia note is a medico-legal document. It should contain:
  - ✓ Statement of date & time of interview.
  - ✓ Relevant positive & negative findings.
  - ✓ A problem list.
  - ✓ ASA physical status class.
  - ✓ Anesthesia plan.



**Department of Anaesthesiology**  
**M.G.I.M.S. KASTURBA HOSPITAL, SEWAGRAM**  
**PRE-OPERATIVE ASSESSMENT RECORD**

Date : .....

Name : ..... Age / Sex : ..... Wt/Bed/OPD : .....

MRD No : ..... CR. No. : ..... Weight : .....

Diagnosis : .....

Surgery Planned : .....

**History of Presenting Complaints :** .....

H/o cough : ..... Dry / Productive / Mucoid / Blood Stained / Frank Blood H/o cold : .....

H/o dyspnoea : ..... At Rest / on Routine Exercise / on heavy exercise / PND. Palpitation : .....

H/o Hypertension : ..... Chest Pain : .....

H/o Diabetes : ..... Exercise Tolerance : (METS) .....

H/o Tuberculosis : ..... H/o Br. Asthma : ..... H/o Allergy (specify) : .....

H/o Previous hospitalisation / Surgery : .....

Addiction (if any) : smoking / alcohol / drugs / Others : / Any other Significant History : .....

Current drug T/t With duration : .....

**GENERAL EXAMINATION :**

GC :	Built :	Height :	Temp :
Pulse :	B. P. :	Resp :	Pallor :
Icterus :	Oedema :	JVP :	Any other :

**AIRWAY ASSESSMENT :**

Dentition : Loose / Bucked / Protruding / Artificial / Edentulous / Missing + | -

Mouth opening : ..... Neck Movement : ..... TMJ mobility : .....

M.P.C. grading : I / II / III / IV. IDL finding : ..... Any other : .....

**SYSTEMIC EXAMINATION :**

Respiratory system : A/E	P/A : Liver / spleen :	C.V.S. ; HR : ..... / min : Regular / Irregular.
Vesicular / Bronchial	* Atelectasis :	S1 / S2 : .....
Crackles / Rhonchi / Wheeze	* Tenderness :	Murmur : .....
Spine	* Rigidity / Guarding	C.N.S. : .....
Examination :	* Palpable mass :	Glasgow Coma Scale Score : .....

**Investigations**

Hb% :	Platelets :	<u>Urine Examination :</u>	<u>Blood Sugar (mg%) :</u>
HcT :	PT/INR	Albumin :	Random :
TLC :	APTT :	Sugar :	Fasting :
DLC :	B. T. :	M/E :	P/P :
P-S :			



Blood Group .....

Sickling / Electro-Phoresis.....

**RENAL FUNCTION TEST : LIVER FUNCTION TEST :**

Blood Urea :

Sr. Proteins :

Total:

Alb :

Glob :

Sr. Creatinine :

Sr. Bilirubin :

Total:

Conj :

Unconj :

Sr. Sodium :

AST :

ALT :

ALK Phosphatase :

Sr. Amylase :

Sr. Potassium :

Sr. CPK : Mb.

Sr. Calcium :

ECG :

X-Ray :

USG :

CT/MRI :

ECHO :

**Risk Assessment : ASA grade**

NYHA..... G.C.S. .... Any Other .....

**Lee's REVISED CARDIAC RISK INDEX**

1. High Risk Surgery .....	Points	Class
2. H/O BID .....	0	I
3. H/O CCT .....	1	II
4. H/O CVA .....	2	III
5. DM on Insulin .....	3 or more	IV
6. Sr. Creat>2.0 .....		

Other Investigation : .....

Anaesthesia Notes

Anaesthesia Notes

Anaesthesia Notes

FITNESS STATUS :

R<sub>x</sub>

Plan :

NBM (hrs).....

XST .....

(Anaesthesiologist)

Informed written Consent .....

Premedication .....

## PREOPERATIVE PREPARATION:

Food and drink should ideally be withheld at least during 6 hours preceding operation. It is to be remembered that gastric emptying time may be considerably delayed in labour. Obstetrical patient should always be taken as patient of full stomach and measures and precautions should be taken to safeguard against ASPIRATION. Patient in the preoperative period is invariably anxious. This "state anxiety" has multifactorial etiology. The best way of allaying this anxiety is by providing a psychological support to the patient.

## SALIENT POINTS TO REMEMBER:

While planning to anaesthetize an obstetrical patient for emergency caesarean section following may be remembered and followed:

1. Assess the patient properly and prepare her adequately.
2. Obstetrical patient should always be taken as a patient of full stomach and necessary measures and precautions should be taken to safeguard against aspiration.
3. Establish IV infusion using 18 G (Green) or 16 G (Grey) IV Cannula. Ensure adequate preloading before giving spinal Anaesthesia.
4. Prevent Aorto – Caval compression. Transport the patient from ward to operating suite in the full lateral position (Journey tilt) and maintain her in left lateral position in intra operative period till delivery of baby.
5. Anaesthetise the patient on a tilting table and keep the sucker instantly ready.
6. Check anaesthetic equipment, oxygen supply and all drugs before you start.
7. Administer drugs as per the body weight. Do not overdose the patient. Never exceed safe dose of local anaesthetic.
8. Keep alternative airway devices viz Proseal LMA, I Gel etc. ready for cases who may turn out to be the patients of difficult intubation.
9. Once the patient has been intubated, always confirm the placement of endotraechal tube.
10. Monitor the patient meticulously in the perioperative period.
11. Detect derangements of vitals (if any),- early and treat them promptly. Do not let these derangements to persist and progress.

## CHECK YOUR PROGRESS

1. With I/V induction, stages of anaesthesia cannot be seen – T/F.
2. As grading of physical status of surgical patient increases so does his / her perioperative morbidity and mortality - T/F.
3. Patient is invariably anxious in the preoperative period - T/F.
4. The anxiety of preoperative period is multifactorial in etiology and best way of allaying this anxiety is by pharmacological / psychological method - T/F.
5. In order to safeguard against aortocaval compression, patient should be transferred from ward to operating suite in full lateral position and should be maintained in the left lateral position in the intra-operative period till the delivery of baby - T/F.
6. Obstetrical patient should always be taken as a case of full stomach and necessary measures and precautions should be taken to prevent aspiration - T/F.



7. Commonly used gaseous anaesthetic agent is  $N_2O$  – T/F.
8. Sodium Thiopentone – an ultra shortacting barbiturate structurally belongs to :
  - a. Oxybarbiturates.
  - b. Methylated Oxybarbiturates.
  - c. Thiobarbiturates.
9. The triad of G Anaesthesia consists of :-
  - a. Narcosis
  - b. Analgesia
  - c. Relaxation            T/F.
10. In regional anaesthesia only two basic components of the triad are observed i.e, there is (a) \_\_\_\_\_; and (b) \_\_\_\_\_ but no (c) \_\_\_\_\_.

### ANSWERS:

1. T
2. T
3. T
4. Psychological
5. T
6. T
7. T
8. C
9. T
10. (a) Analgesia (b) Relaxation (c) Narcosis

### Further Reading:

- Obstetrical Analgesia and Anaesthesia by J. S. Crawford.
- A practice of Anaesthesia – Wylie and Churchill – Davidson.
- Lee's Synopsis of Anaesthesia.

# 03

## Medico Legal and Ethical Aspects Of Anesthesia

---

In the practice of anaesthesia, the untoward incidents and complications are quite often of a serious nature exposing the Anaesthesiologists to charges of both civil and criminal negligence. Adequate knowledge of the legal aspects of the profession would help discharge the duties confidently and to the best of their ability. This module is structured with the following learning objectives.

### LEARNING OBJECTIVES

- i. After completing this session trainee would be able to describe;The legal aspects of a patient doctor relationship.
- ii. Relevant provisions of Indian Medical Council (Professional Conduct and Ethics) Regulations, 2002.
- iii. Consumer law as applicable to medical profession.
- iv. Legal duties of an Anaesthesiologist.
- v. Legal protection available to medical professionals.
- vi. Importance of consent in anaesthesia and surgery.
- vii. Principles of law on medical negligence, civil and criminal.
- viii. Important rulings of the Supreme Court in relation to negligence of doctors.

Before looking into the legal aspects it is imperative that the ethical aspects expected out of professional practice are discussed. So, we discuss aspects relating to ethical conduct to start with, before going into questions like what constitutes establishment of doctor patient relationship, negligence and consequences, duties of Anaesthesiologists etc.

### PROFESSIONAL CONDUCT AND ETHICS

By notification No. NMC-21(2)2001-Regn, the Medical Council of India, with the previous approval of the Central Government, has made regulations relating to the Professional Conduct, Etiquette and Ethics for registered medical practitioners. The regulations are called the Indian Medical Council (Professional Conduct and Ethics) Regulations, 2002. Every member of the profession must be fully conversant with the regulations and abide by them.

Salient features of the regulations are as below:

1. Physicians should try continuously to improve medical knowledge and skill and should make available to their patients and colleagues the benefits of their professional attainments.
2. Though a physician is not bound to treat each and every person asking his services, he should be mindful of the high character of his mission and his responsibilities.

3. Once a case has been undertaken, the physician should not neglect the patient, nor should he withdraw from the case without giving notice to the patient, his relatives or his responsible friends sufficiently long in advance of his withdrawal to allow them to secure another medical attendant.
4. He should neither exaggerate nor minimize the gravity of a patient's condition.
5. Medical records should be maintained for a period of 3 years. If any request is made for medical records either by patients/authorized attendant or legal authorities involved, the same may be duly acknowledged and the documents shall be issued within the period of 72 hours.
6. Maintain a Register of Medical Certificates showing full details of certificates issued and entry of identification marks of the patient and keep a copy of the certificate. The medical certificate shall be prepared as per the format given in the Regulations.

In addition to the duties as a registered medical practitioner, the Anaesthesiologist is expected to provide a higher level of care in his/her area of training.

After having dealt with the ethical aspects, let us know go into some pertinent legal aspects of medical practice.

## LEGAL ASPECT OF DOCTOR-PATIENT RELATIONSHIP

As soon as a doctor agrees to treat a patient, the doctor-patient relationship is established and the duty of the doctor towards the patient starts. The relationship may either be in the form of a contract or without a contract.

In hospitals or health centres run by government, municipal bodies or charitable institutions where patients are treated free of charge, the direct contract between the doctor and the patient does not exist unlike one seen in private practice. Once the patient is taken for treatment, the doctor has the responsibility to treat him with due care and skill. The new Regulations from the Medical Council of India 2002, too, call for the doctor to fulfill his obligations towards such patients with reasonable care and skill.

### Instances where a doctor-patient relationship is not established is listed below:

- The doctor performs an examination for life insurance purposes.
- He makes a pre-employment medical examination for a prospective employer.
- He is appointed by trial Court to examine the accused for any reason.
- Assessment of injuries in case of assaults.
- Assessing drunkenness in prohibition and vehicular accident cases.
- Evaluation of disabilities for purposes like compensation, retirement benefits, etc.

In these situations, the doctor examines the person in his official capacity at the instance of police or a court or according to other laws in force.

## DUTIES OF AN ANAESTHESIOLOGIST

The professional duties of an Anaesthesiologist entail a high degree of knowledge, skill and experience than of an MBBS doctor. The duty starts as soon as the Anaesthesiologist agrees to take up the case and continues till complete recovery from anesthesia and its after-effects. The duties from the legal point of view may be enumerated as below:

i. To decide whether to undertake a case:

The Anaesthesiologist has to decide (a) whether he is competent to administer anaesthesia to the case, and (b) whether he has an adequately equipped and staffed operation theatre to administer anaesthesia and to deal with any complication or emergency that may arise.

ii. To carry out pre-anaesthetic check-up:

A proper assessment of the case regarding the anaesthetic risks should be made. High risk cases should be identified and dealt with properly.

In *Dr. U.K. Kini v. K. Vasudeva Pai*, 2001 (Karnataka HC), cardiac arrest of the patient occurred on account of not carrying out pre-anesthetic check-up properly. The patient died. The surgeon and the Anaesthesiologist were held liable for negligence and liability was fixed in the ratio of 1:3 against the surgeon and the Anaesthesiologist.

iii. To obtain consent for anesthesia (dealt in detail below).

iv. Identification of the patient before anaesthesia.

v. To check anaesthetic equipment.

He/She must check all the anaesthetic equipment and gas cylinders including ventilator, monitor, etc. before taking the patient for anaesthesia. He/She must ensure that there are no faulty connections or leak of gases and issues with electric connection, and so on.

vi. Induction and maintenance of anaesthesia with high degree of skill and care.

vii. To ensure proper recovery from anaesthesia

He/She should take necessary precautions to ensure a smooth recovery. He/She should be watchful of intra- and post-anaesthetic complications which should be anticipated, detected and managed without undue delay.

viii. To exercise reasonable degree of knowledge, skill and care

It is the settled principle that a medical practitioner is expected to exercise not the highest but a reasonable degree of skill, knowledge and care in the treatment of his patient. The word 'reasonable' is not precise, and several facts have to be taken into consideration to decide what is 'reasonable'. It has to be judged from the qualification and experience of the doctor and from the given set of circumstances in which he treats the patient. A general practitioner is expected to possess the skill that is required of a general practitioner and cannot be compared to that of a specialist. A specialist is expected to exercise a higher degree of skill that is expected of a specialist. However, the amenities available in a remote area would not be the same as in a teaching hospital and expectations on management will also differ.

ix. Maintenance of records

A detailed record of all the administrations of anaesthesia must be maintained by the Anaesthesiologist. It contributes to the proper care of the patient, and helps a second Anaesthesiologist who may take charge of the case.

For **medico-legal purpose**, the record must be complete, accurate, legible, duly signed and

contemporaneous i.e., the events should be recorded as soon after as they take place. Any correction made in the record should be made in such a way that it does not create any doubt in the mind of one who examines it. It must not be tampered with. A record is the most important weapon of defense of the Anaesthesiologist in case of litigation. Once it is concluded that the record has been tampered with, it loses all its credibility as an effective document. Not only that, an adverse inference may be drawn by the court regarding the genuineness of the treatment mentioned in it.

The document should contain:

- The name, age, sex, hospital, Case Record number and address of the patient.
- Summary of pre-operative assessment.
- Pre-medication given.
- Date and time of operation.
- Names of surgeons and Anaesthesiologist.
- The type of operation.
- The procedure of induction and maintenance and reversal of anaesthesia.
- The drugs given in chronological order.
- Record of vital signs: e.g. pulse, blood pressure, respiration, SPO<sub>2</sub> and other details; recorded as frequently as required, so that the exact time when there is any change in the vital signs can be traced.
- I.V. fluids/blood given.
- Any complication during anaesthesia: when detected and how managed.
- Recovery from anaesthesia.
- After-effects, if any, and how managed?

***Rajiv Sharma & others v. Helvetia Klinik Pvt. Ltd. & Others, (NCDRC), 2010:*** Caesarean section was performed by the obs-gynaecologist of the clinic under G.A. but the patient did not recover from anaesthesia due to neuro-muscular block. She was shifted to Mohinder hospital for continuous ventilatory support and was later referred to Sir Gangaram hospital but could not be saved. The National Commission inferred that there was discrepancy in the consent form, some entries were inserted later and was thus tampered with; proper drugs for anaesthesia and also for reversal were not administered in correct dosage; there was delay in shifting the patient to another hospital, which too was not well-equipped and she had to be shifted again to a third hospital; shifting was done much after the complications started; the ICU facilities were deficient; the Anaesthesiologist failed to administer drugs in correct doses for anaesthesia and also reversal; he did not monitor properly and failed to reverse in time so that patient became hypoxic and died. Compensation of a lump sum of Rs. 10,00,000/- was awarded with interest to be paid jointly by the hospital and the Anaesthesiologist.

#### x. To attend an injured or critically ill person to preserve life

The role of an Anaesthesiologist in managing a critically ill person cannot be overemphasized. In the case Pt Parmanand Katara v. Union of India & Ors, AIR 1989 SC 2039, the Supreme Court has held that:

- i. Medico-legal formalities should not come in saving the life of an injured.
- ii. Every doctor whether at a government hospital or otherwise has the professional obligation to extend his services with due expertise for protecting life.
- iii. Police and courts should keep in mind that a doctor should not be unnecessarily harassed

for purposes of interrogation or for any other formalities and should not be dragged during investigations to the police station; it should be avoided as far as possible.

- iv. The courts will not summon doctors to give evidence unless it is necessary, and if summoned they should not be made to wait and waste time unnecessarily. The law courts who always have respect for the members of the medical profession, should see that they do not have to wait for long. Where the facts are clear, unnecessary harassment of the doctors either by requesting for adjournments or by cross-examination should be avoided so that the apprehension in the minds of doctors which prevents them from discharging their duty to a suffering person is removed.

Denial of admission to a critically injured / critically ill patient in a government hospital is violation of the right to life under article 21 of the Constitution: The Supreme Court, in *Paschim Banga Khet Mazdoor Samity & Others v. State of West Bengal, 1996*, held that preservation of life is of paramount importance. The government hospitals run by the state and the medical officers employed therein are duty bound to extend medical assistance for preserving life. The state is vicariously liable for failure on the part of a government hospital to provide timely treatment to such cases.

## CONSENT IN ANAESTHESIA

Two or more persons are said to consent when they agree upon the same thing in the same sense (section 13 of Indian Contract Act 1872). Consent from a patient must always be obtained by the Anaesthesiologist for anaesthesia since administration of anaesthesia without his/her consent is assault in law, even if it is beneficial to the patient and done in good faith. Consent is mandatory for every medical examination and treatment and it must be freely given. Consent is said to be free when it is not caused by coercion, undue influence, fraud, misrepresentation, or mistake. When obtained in these situations it does not amount to a valid consent. A valid consent means that it has been obtained after the patient has been informed and made to understand about:

- The nature of his condition,
- The nature of the proposed anaesthesia, its benefits and risks,
- Any alternative procedure, and the benefits and risks of the procedure,
- The relative chances of success or failure of both the procedures so that the patient may decide whether to accept or reject the procedure.

All disclosures must be in language the patient can understand. When it is obtained from the patient in writing and in the presence of a disinterested witness, it will minimize the chances of litigation. However, obtaining consent does not give protection to a doctor from a charge of negligence in treatment.

Consent should be broad enough to cover everything proposed and should be in proper form and suitably drafted for the proposed anaesthesia and surgery. Consent for both anaesthesia and surgery can be taken on the same form. It should be obtained before the patient is pre-medicated. The patient should be informed that he has a right to refuse the treatment and that if he refuses, the result may go against him. In spite of this if the patient refuses, he cannot be given that treatment. However, the patient's refusal should be brought in the record and the patient's signature should be obtained.

Though an oral consent is legally valid, a written consent should always be preferred as it is a permanent document and obviates any problem arising later. A person who gave only oral consent may deny at a later date that he had ever given any consent. A written consent must be preserved as a part of the record.



The Supreme Court, while delivering judgment in *Samira Kohli v. Prabha Manchanda & Anr.*, AIR 2008, has issued clear guidelines to be followed how consent for diagnosis and / or treatment is to be obtained:

- The consent given by the patient authorizes the doctor to carry out only the procedure for which express consent is given. The only exception to this rule is the principle of necessity by which the doctor is permitted to perform further or additional procedure. The exception is restricted to cases where the patient is temporarily incompetent (being unconscious) and undertakes the procedure delaying of which would be unreasonable because of the imminent danger to the life or health of the patient.
- A doctor has to seek and secure the consent of the patient before commencing a treatment (including surgery). The consent so obtained should be real and valid, which means that: the patient should have the capacity and competence to consent; his consent should be voluntary; and his consent should be on the basis of adequate information concerning the nature of the treatment procedure, so that he knows what he is consenting to.
- The adequate information to be furnished by the doctor (or a member of his team) should enable the patient to make a balanced judgment as to whether he should submit himself to the particular treatment or not. This means that the doctor should disclose – (a) nature and procedure of the treatment and its purpose, benefits and effect; (b) alternatives if any available; (c) an outline of substantial risks; and (d) adverse consequences of refusing treatment. But there is no need to explain remote or theoretical risks involved which may frighten or confuse a patient and result in refusal of treatment. Similarly, there is no need to alleviate refusal to take treatment which may persuade a patient to undergo a fanciful or unnecessary treatment.
- Consent given only for a diagnostic procedure cannot be considered as consent for therapeutic treatment. Consent given for a specific treatment procedure will not be valid for conducting some other treatment procedure. The fact that the unauthorized additional surgery is beneficial to the patient, or it would save considerable time and expense to the patient from pain and suffering in future, are not the grounds for defense in an action in tort for negligence or assault. The only exception to this rule is where the additional procedure, though unauthorized, is necessary in order to save the life or preserve the health of the patient and it would be unreasonable to delay such unauthorized procedure until patient regains consciousness and takes a decision.
- There can be a common consent for diagnostic and operative procedures. There can also be a common consent for a particular procedure and an additional or further procedure that may become necessary during the course of surgery.
- The nature and extent of information to be furnished by the doctor to the patient to secure the consent need not be of the stringent and high degree but should be of the extent which is accepted as normal and proper by a body of medical men skilled and experienced in the particular field. It will depend upon the physical and mental condition of the patient, the nature of the treatment, and the risk and consequences attached to the treatment.

## PATIENT AS CONSUMER AND IMPLICATIONS

With the establishment of quasi-judicial tribunals known as Consumer Disputes Redressal Forum/ Commission under the Consumer Protection Act, 1986, it has become very easy for an aggrieved consumer to get a speedy, economical and effective relief through them. There is growing awareness in people and they have now high expectations from the doctors. On the other hand, doctors particularly in government employment do not appear to be adequately aware of the legal aspect of the profession including their rights and the protection that law has provided them.

Though the principles of law on medical negligence observed before the Consumer Forum are the same as adopted in a civil court, a sufferer is always keen to take the shelter of Consumer Forum as it is very easy to get a speedy, economical and effective relief through the Forum. In case of a criminal negligence, the case has to be put up before a criminal court either by the police or by the party as a private complaint. The Consumer Forum entertains complaints only of a civil nature. Under the Act, medical negligence is covered as 'deficiency in service'. Under the above Act, the first question to be decided is whether a patient is a consumer of his doctor/hospital or not. A patient, who is not a consumer as defined in the Act, cannot pursue his grievance before a Consumer Forum and he should take recourse to civil court for claiming relief.

#### i. Is patient a consumer of his doctor/hospital?

The Supreme Court in *Indian Medical Association vs. V.P Shantha & others*, III(1995)CPJ 1 (SC) has maintained that members of medical profession do not enjoy immunity against claims of compensation in case of negligence, and that medical service is a 'service' under the Act and a patient is a consumer of his doctor and hospital except under certain situations. The following conclusions have been drawn by the Court:

- Medical service rendered to a patient by a medical practitioner is a 'service' under the Act, except where the service is rendered free of charge to every patient.
- Where service is rendered free of charge to all patients, such a service is outside the definition of 'service' under the Act. A token amount paid for registration purpose only would not make any change.
- Service rendered free of charge to those persons who cannot afford to pay where other persons are treated on payment of charges, is included in the definition of 'service'.
- Service rendered at a Government hospital where services are rendered on payment of charges and also rendered free of charge to other persons, the free service would also fall within the ambit of 'service' under the Act.
- Service rendered where charges are borne by the insurance company or by the employer would also constitute 'service' under the Act.

In accordance with the above guidelines, it can be decided whether a patient is a consumer of his doctor/hospital or not:

#### ii. A patient is a consumer of his doctor / hospital, where —

- He pays for the medical service.
- He is rendered medical service free of charge as he cannot afford to pay at a non-government hospital / nursing home where charges are required to be paid by others.
- He is rendered free medical service at a government hospital where services are rendered on payment of charges.
- Where charges are paid by insurance company.
- Where the employer bears the expenses of the services, the employee and the members of his family are consumers.

#### iii. A critically injured patient having no money to pay is a consumer:

*In Pravat Mukherjee v. Ruby General Hospital, 2005, (NC)*, where a critically injured patient was brought to the hospital with no relatives or attendants and had no money to pay for the medical expenses, the National Commission held that such a patient should be treated as a poor patient and on that basis, he is a consumer even if no payment has been made by him.



#### iv. A patient is not a consumer of his doctor, where —

- Service is rendered free of charge to all patients, rich and poor alike.
- A person undergoes free sterilization operation at a government hospital or undergoes an operation in a free eye camp.
- A central government servant receives free medical services under CGHS.
- Doctor-patient relationship is not established.

## NEGLIGENCE IN MEDICAL PRACTICE

A medical professional should not only be aware of his professional duties, but should also know what constitutes medical negligence and should keep away from any act or omission that may amount to negligence and make him liable for an action against him.

Negligence, in general, is the breach of a duty to take care which results in damage to the person receiving service. It is want of proper care or attention in rendering service judged from the standards of performance by a reasonable man. The Supreme Court, in *Poonam Verma v. Ashwin Patel & Ors*, 11(1996) CPJ 1 (SC), has defined 'negligence' as thus:

*“Negligence as tort is the breach of a duty caused by omission to do something which a reasonable man would do, or doing something which a prudent and reasonable man would not do”.*

The Court has described **three Constituents of negligence**:

- i. A legal duty to exercise due care;
- ii. Breach of the duty, and
- iii. Damage as a consequence.

#### i. Legal Duty to Exercise Due Care

The first question to be considered is whether the doctor had a legal duty to exercise due care to the patient, i.e., whether the doctor has entered into a doctor-patient relationship with the patient. A doctor does not have a legal duty towards a patient with whom he has no such relationship. Where such a relationship exists, he has a legal duty to render medical service to the patient, irrespective of whether the relationship is contractual or the service is rendered gratuitously.

#### ii. Breach of the duty

Once a medical practitioner has undertaken to render medical service to a patient there should not be any breach of the duty as long as the doctor-patient relationship exists. The question whether a medical practitioner has committed any breach of his duty in care of his patient is based on certain settled principles as follows:

## PRINCIPLES OF LAW ON MEDICAL NEGLIGENCE

#### i. Doctor should possess a minimum degree of competence:

In *Indian Medical Association v V.P. Shantha*, 111 1995 (3) CPR 412 (SC), on the question of professional liability of a doctor, the Supreme Court held that medical profession is a 'profession' and 'professions' are different from 'occupations', and said,

*“...professions operate in spheres where success cannot be achieved in every case and very often success or failure depends upon factors beyond the professional man's control.”*

Therefore, what does the Court expect from a medical professional:

“...the approach of the courts is to require that professional men should possess a certain minimum degree of competence and that they should exercise reasonable care in the discharge of their duties.”

In *Poonam Verma v Ashwin Patel & Ors*, II (1996) CPJ 1 (SC), the Supreme Court has made very clear as to what is expected of a doctor:

“It is true that a doctor or a surgeon does not undertake that he will positively cure a patient nor does he undertake to use the highest possible degree of skill, as there may be persons more learned and skilled than himself, but he definitely undertakes to use a fair, reasonable and competent degree of skill.”

“The approach of the courts is to require that professional men should possess a certain minimum degree of competence and they should exercise reasonable care in the discharge of their duties.”

## ii. Doctor's Skill and Bolam test:

A doctor is not expected to exercise the highest degree of knowledge, skill and care as these may not be achieved by anyone. He should apply only a reasonable degree of care. The 'reasonable degree' is adjudged by the qualification, experience and the set of circumstances under which he renders the medical service. If another prudent and reasonable doctor working under the similar situation would have done what this doctor has done, he cannot be held negligent as judged by the well-known Bolam's test, described in the judgment in *Bolam v. Friern Hospital Managing Committee* (1957) 2 All ER 118.

**Bolam Test:** “A man need not possess the highest expert skill; it is well established law that it is sufficient if he exercises the ordinary skill of an ordinary competent man exercising that particular art. In case of a medical man, negligence means failure to act in accordance with the standards of reasonably competent men at the time. There may be one or more perfectly proper standards, and if he conforms to one of these proper standards, then he is not negligent.”

## iii. Line of management & consequences

There are several judgments given by the Supreme Court which unequivocally say that a doctor is not a guarantor of safety, he does not guarantee a cure. He is expected only to exercise a reasonable degree of knowledge, skill and care. The Supreme Court, in the case of alleged negligence against a surgeon, in *Laxman Balakrishna Joshi v. Trimbak Bapu Godbole & Anr*, (1969) 1 SCR 206 at 213; AIR 1969 SC 128, has held:

“The duties which a doctor owes to his patient are clear. A person who holds himself out ready to give medical advice and treatment impliedly undertakes that he is possessed of skill and knowledge for the purpose. Such a person when consulted by a patient owes him certain duties, a duty of care in deciding whether to undertake the case, a duty of care in deciding what treatment to give or a duty of care in the administration of that treatment. A breach of any of these duties gives a right of action for negligence to the patient. The practitioner must bring to his task a reasonable degree of skill and knowledge and must exercise a reasonable degree of care. Neither the very highest nor a very low degree of care and competence judged in the light of the particular circumstances of each case is what the law require”.

*Lord Justice Denning in Roe v. Minister of Health* (1954-2 All England Reporter 181) said,

We should be doing a disservice to the community at large if we were to impose liability on hospitals and doctors for everything that happens to go wrong. We must insist on due care for the patient at every point, but we must not condemn as negligence that which is only a misadventure. Where there are two different schools of thought in the treatment of a patient including administration of anaesthesia, a doctor can take recourse to any of them he believes in, and he cannot be held guilty

of negligence only because some persons have a contrary view.

“The medical man must, therefore, exercise reasonable skill and care, measured by the standard of what is reasonably to be expected from the ordinary competent practitioner of his class. If he does so, he will have discharged his duty and cannot be held answerable even if the treatment has untoward results. For the medical man is not an insurer; he does not warrant that his treatment will succeed or that he will perform a cure... But he will not even be liable for every slip or accident.”

In every case of anaesthesia and surgery there are certain risks that are inevitable in spite of all due care. The anaesthetic drugs carry with them rare but serious risk of anaphylaxis. Mortality is inevitable in a small percentage of cases in spite of due precautions and adequate management. Where in spite of all possible and timely care and management the patient's life is lost, the doctor is not to be held guilty.

In *Achyutrao Haribhau Khodwa v Government of Maharashtra, 1996 ACJ 505*, the Supreme Court held:

“Medical opinion may differ with regard to the course of action to be taken by a doctor treating a patient, but as long as a doctor acts in a manner which is acceptable to the medical profession and the court finds that he has attended on the patient with due care, skill and diligence and if the patient still does not survive or suffers a permanent ailment, it would be difficult to hold the doctor to be guilty of negligence.”

Mr. Justice Barry, in *Moore v. Lewisham Group (1980) 1 All England Reporter 650*, observed:

“When there are two genuinely responsible schools of thought about the management of a clinical situation, the courts could not do greater disservice to the community or the advancement of medical science than to place the hallmark of the legality upon one form of treatment.”

In order to hold a doctor negligent, the finding of damage in the shape of loss i.e., complication or death must be present. A doctor is negligent only when the damage is done to the patient as a consequence of the breach of his duty. There must be a direct relationship between the breach of the duty and the damage. If a patient suffers a complication which is not related to the breach of the duty of the doctor, the latter cannot be held responsible merely because the patient was under his treatment when the complication developed. When a complication arises, he should manage it with reasonable degree of skill, knowledge and care, and should not do or omit to do anything that a reasonable counterpart would have done in the given situation. Further, if a complication develops in spite of the reasonable care taken by the doctor, he cannot be held liable.

## WHERE CAN A COMPLAINT BE FILED

Cases against negligence may be brought against a medical practitioner in a Civil Court or a Criminal Court. Cases of professional misconduct can be filed before the Medical Council. An action for negligence can be brought before a Consumer Forum by a patient if he happens to be a consumer of the medical service under the Act. The course of action depends upon the type of negligence.

### Civil Negligence

This is a form of negligence, in which a patient or his legal heirs bring an action of compensation in Civil Court or Consumer Forum against the medical practitioner, who had a legal duty to take care of the patient, and committed breach in his duty with consequent damage to the patient. If the patient is able to establish negligence on the part of the practitioner, he is entitled to compensation for the sufferings due to the complication. The patient has a choice either to file a civil suit in a Civil Court or file a complaint before the Consumer Forum, but he cannot take recourse to both of them. Many

patients prefer to take the option of the Consumer Forum because of the speedy and inexpensive nature of the process followed by the Forum.

## Criminal Negligence

Here the negligence is graver than the civil negligence. When a doctor, whether qualified or unqualified, has committed an act or made an omission which is extremely or grossly rash or grossly negligent, and the grossly negligent act is proved to be the direct and proximate cause of the patient's death, it is an act of criminal negligence. In such cases, the doctor may be prosecuted by the police and charged in a Criminal Court under Section 304-A I.P.C. and is punishable with imprisonment for a term which may extend up to two years, or with a fine, or with both. The Section 304-a I.P.C. deals with causing death by negligence and reads as thus:

“Whoever causes the death of any person by doing any act so rash or negligent not amounting to culpable homicide, shall be punishable with imprisonment of either description (i.e., rigorous or simple) for a term which may extend to two years, or with fine or with both”.

- i. **What is a rash act.** Rashness is thoughtlessness, the tendency to rush headlong, with no eyes on the probable or possible consequences of the undertaken act. It is doing some positive act which no man in his senses or no prudent and reasonable man in his place, would ever do.
- ii. **Grossly negligent act.** Negligence has been described above, and such negligence must be gross, resulting from gross carelessness or gross ignorance. For example, a physician/surgeon proceeds with laparotomy, thinking that nothing untoward will happen.
- iii. **There should be absence of intention to cause death/severe morbidity.** In a case of criminal negligence there is a presumption of absence of intention to cause death of the patient, and the want of knowledge that the act done will most probably result in death/ severe morbidity.
- iv. **There is proximate causal relationship between the act and the death/ severe morbidity.** Direct and immediate relationship between the rash or negligent act of the doctor and the death of the patient must be established beyond doubt. As the charges are grave, the proof should be clear. It must be clear that, but for the doctor's alleged gross rashness and/or negligence, the patient would not have died/ severe morbidity in the ordinary course.

In the case of *Kalawati v. State of Himachal Pradesh, 1988 ACJ 780*, the High Court of Himachal Pradesh, while applying Section 304 IPC held the hospital staff and state to be liable. Death of two patients had occurred in a government hospital where nitrous oxide was administered in place of oxygen during operation as pipes of the two gases were interchanged in the process of cleaning by a ward boy. He was not supposed to remove and replace the gas pipes, nor did he inform the higher authorities that he had done so. Checks and procedures outlined were not conducted by the Anaesthesiologist before the operation who could have detected the interchange of pipes. Negligence of hospital staff was proved and the state was held liable for the damages.

## A doctor is not to be arrested on charge of criminal negligence:

The offence under Section 304-A I.P.C. is bailable i.e. the doctor is entitled to bail as a matter of right. As the offence is punishable at the most with two years' imprisonment and/or with fine, the amount of bail that can be legitimately demanded cannot be high. A police officer cannot act unreasonably and under the pretext of non-furnishing of bail, put him under arrest and detention. Any such act on the part of the police officer will expose him to being held up, tried and convicted of an offence of wrongful confinement punishable under Section 342 I.P.C.

In *Jacob Mathew vs. State of Punjab & Anr., III (2005) CPJ 9 (SC)*, it was alleged that the doctor failed

to provide oxygen cylinder to an old patient in a terminal stage of cancer for 20-25 minutes in the ward and the patient died. Two doctors were prosecuted u/s 304-A IPC. The Supreme Court while giving Judgement, defined what constitutes criminal negligence;

### To constitute criminal negligence;

- Negligence must be gross;
- Death should be the direct result of the act of the doctor;
- No sensible medical professional would intentionally cause death or injury;
- Deviation from normal practice is not necessarily evidence of negligence;
- To establish liability, it must be shown that, (i) there is a usual and normal practice; (ii) the doctor did not adopt it; (iii) the course adopted by him is that no professional man of ordinary skill would have taken while acting with ordinary care;
- The charge of negligence arises out of failure to use some particular equipment, and not if the equipment was not generally available at the point of time when it should have been used;
- In case of an accident while treating, there is no liability of the doctor;
- Higher the emergency, more are the chances of 'error of judgment';
- An error of judgment on the part of the doctor is not negligence per se.
- He cannot be held liable only because he chose to follow one of the accepted procedures and the result was a failure (At times he has to make a choice between the devil and the deep sea, and he has to use the lesser evil).
- Simply because a treatment or surgery failed, he cannot be held liable for negligence;
- Burden is on the prosecution to prove criminal negligence;
- The investigating police officer is not conversant with the medical science. He should obtain a competent, impartial and unbiased medical opinion preferably from a government doctor who should apply Bolam's test; (discussed above).
- Doctor should not be arrested as routine procedure, unless the investigating officer finds that the doctor may not be available to face the prosecution.
- Indiscriminate prosecution of doctors for criminal negligence does no good to the society. Medical profession needs protection against unjust prosecution. Loss of reputation cannot be compensated;
- The Court said, "A practitioner faced with an emergency ordinarily tries his best to redeem the patient out of his suffering. He does not gain anything by acting with negligence or by omitting to do an act. Obviously, therefore, it will be for the complainant to clearly make out a case of negligence before a medical practitioner is charged with or proceeded against criminally. A surgeon with shaky hands under fear of legal action cannot perform a successful operation and a quivering physician cannot administer the end-dose of medicine to his patient."

"If the hands be trembling with the dangling fear of facing criminal prosecution in the event of failure for whatever reason – whether attributable to himself or not, neither can a surgeon successfully wield his life-saving scalpel to perform an essential surgery, nor can a physician successfully administer the life saving dose of medicine. Discretion being the better part of valour, a medical professional would feel better advised to leave a terminal patient to his own fate in the case of emergency where the chance of success may be 10% (or so), rather than taking the risk of making a last ditch effort towards saving the subject and facing a criminal prosecution if his effort fails. Such timidity forced upon a



doctor would be a disservice to society.”

**Charan Singh v. Healing Touch Hospital, 2003(2) CPR 95 (NCDRC).** Spinal anesthesia for removal of stone in urethra—paralysis of left side of the body—radiculitis—no negligence held: The National Commission held that the Anaesthesiologist followed the accepted procedure and settled position. In such circumstances he cannot be held guilty of negligence especially when all over the world it is an accepted procedure having less than 1% risk. Unfortunately, the patient fell in that 1% group.

## ROLE OF EXPERT EVIDENCE IN CASES OF GROSS NEGLIGENCE

*The Supreme Court in Martin D'Souza v. Mohd. Ishfaq*, 1 (2009) CPJ 32 (SC), where the National Consumer Disputes Redressal Commission (NCDRC) ignored the expert evidence and held the doctor negligent, the Supreme Court, in the appeal, directed that whenever a complaint is received against a doctor or hospital by the Consumer Forum or criminal court, then before issuing notice to the doctor or hospital, the Consumer Forum or criminal court should first refer the matter to a competent doctor or a committee of doctors specialized in the field relating to which the medical negligence is attributed, and only after that doctor or committee reports that there is a prima facie case of medical negligence should notice be then issued to the concerned doctor/hospital. This is necessary to avoid harassment to doctors who may be ultimately found to be not negligent. The Apex Court further warned the police officials not to arrest or harass the doctors unless the facts clearly come within the parameters laid down in Jacob Mathew's case; otherwise, the policemen will themselves have to face legal action. The Court further went on to say that the courts and Consumer Fora are not experts in medical science, and must not substitute their own views over that of specialists.

But, the Division Bench of the Supreme Court in *V. Kishan Rao v. Nikhil Super Speciality Hospital & Anr., III (2010) CPJ1 (SC)*, has held that in cases where medical negligence is evident and obvious, expert evidence is not necessary and referring such cases to a competent doctor for opinion cannot be binding. The direction to refer the case to expert must be confined to the particular facts of the case. If any of the parties wants to put up expert evidence, the Forum can allow the parties to do so in the facts of the case. The first duty of the expert in these cases is to explain the technical issues so that it can be understood by a common man. His second duty is also to assist the court in deciding whether the act of the doctor constitutes negligence. In most of the cases the question whether a doctor is negligent or not is a mixed question of fact and law and the Forum is not bound in every case to accept the opinion of the expert.

*Johnson Thomas & Others v. Bishop Vayalil Medical Center, I (2010) CPJ 164 (NC)*: In this case, caesarean section was performed on a second gravida under general anaesthesia, the patient did not recover from anaesthesia and died after 8 days in spite of being shifted to three hospitals in succession. The State Commission, Kerala found the doctors concerned as not negligent. The National Commission, in the appeal, sought for an opinion from a Medical Board of AIIMS, New Delhi. The committee made the following observations: (i) It is unusual to give G.A. to a pregnant patient with history of recent rhinitis with no contraindication for a neuraxial block; (ii) The patient was preoxygenated for 5 minutes and then intubated, IPPV maintained with 100% oxygen, bronchospasm and cyanosis were noted in 2-3 minutes. It is unlikely for an ASA grade I patient in this situation to develop hypoxic encephalopathy; it is likely that immediate aggressive treatment for bronchospasm was not given; (iii) anaesthesia record was poorly maintained; (iv) treatment for severe bronchospasm was not aggressive; (v) Lasix and soda bicarb are not normally given in bronchospasm; (vi) the total duration of 125 minutes for surgery is unusual in the absence of any intra-operative complications or difficulty. The National Commission concurred with the opinion of the committee and held the hospital and the management liable to pay a lump sum of Rs. 10 lacs to be paid to the complainants.

## LEGAL PROTECTION TO MEDICAL PRACTITIONERS

Certain provisions of the Indian Penal Code provide protection from liability for unfortunate consequences where medical men are not at fault and have exercised their utmost care and attention and acted with the best intentions:

### **One such provision deals with unintentional causing of grievous hurt or death (Section 88, I. P.C.).**

We will use an illustration to explain how the provision operates: A surgeon, knowing that a particular operation is likely to cause the death of his patient, but not intending to cause his death, and in good faith and for his benefit, performs that operation on him with his consent, he has committed no offence.

### **Another provision is one which covers act done in good faith for benefit of a person without consent (Sec. 92, I.P.C.).**

A few illustrations are given below to explain the section.

**(a)** Z is thrown from his horse, and is insensible. A, a surgeon, finds that Z requires to be trepanned. A not intending Z's death, but in good faith, for Z's benefit, performs the trepan before Z recovers his power of judging for himself. A has committed no offence.

**(c)** A, a surgeon sees a child suffers an accident, which is likely to prove fatal unless an operation be immediately performed. There is no time to search for the child's guardian. A performs the operation in spite of the entreaties of the child, intending, in good faith, for the child's benefit. A has committed no offence.

## DEATH ON OPERATION TABLE (DOT): A SPECIFIC INSTANCE TO WARD OFF

An Anaesthesiologist may come across a situation where patient may die on the operation table during anaesthesia or during recovery from anaesthesia. Such a grave incident may happen due to an act of negligence or omission or otherwise by the Anaesthesiologist. Death may also occur due to some lapse on the part of surgeon or due to some surgical cause.

### **Fixing the Responsibility: Anaesthesiologist or surgeon?**

The dividing line of responsibility between the surgeon and the Anaesthesiologist may not always be well-defined. The surgeon is responsible for his decision to undertake a case for surgery, the extent of surgery and whether to cut-short or extend a procedure. He is guided by the Anaesthesiologist as to the pre-operative status of the patient and his condition during the operation. Intravenous fluid replacement and blood transfusion is a function of both the surgeon and the Anaesthesiologist. The choice of anesthesia is made by the Anaesthesiologist in conjunction with the surgeon and the patient. Modern surgery is a team work with a joint responsibility. Despite all care, untoward incidents can happen.

**Mumbai Grahak Panchayat v. Dr. R.B. Fadnavis, (NCDRC), 1996: Liability of an Anaesthesiologist in a complication arising in O.T.:** In this case where death had occurred during anaesthesia, the National Commission observed that the exact time when cardiac arrest occurred is not clear; as per record the B.P. was not properly controlled; there was no proper record of resuscitation; cause of death was unexplained; and in this situation police was not informed. The National Commission held the Anaesthesiologist liable, and observed that an Anaesthesiologist is liable irrespective of whether he is a full time or a part-time employee or a visiting consultant called by the doctor, hospital or by the patient. A direct contract between the patient and the Anaesthesiologist is not mandatory.



It was held that inside the operation theatre, it is the joint responsibility of the Anaesthesiologist and the surgeon. The hospital and the surgeon were held vicariously liable for the negligence of the Anaesthesiologist. The court may in such cases apportion the liability of the Anaesthesiologist, surgeon and the hospital in a particular ratio, or hold them jointly and severally liable.

### In case of death

- The surgeon, Anaesthesiologist and his staff should not panic. On the contrary, the situation should be explained to the relatives and assurance should be given that whatever best could be done under the circumstances have been done.
- The hospital authorities and the police should be informed even if the relatives are not willing.
- The staff should not leave the theatre.
- Nothing should be removed from the operation theatre including the broken ampoules, empty bottles of I.V. fluids and blood, used syringes, etc. till the police arrives (not that they enter OT) and permits to remove them.
- If the cause of death is clear, the postmortem examination may not be ordered by the police.
- If the cause of death is obscure, the team of the operation theatre should insist for a postmortem examination for their own safety and defense.
- If the relatives feel that some negligent act has been done, the doctor should not hesitate in explaining them the real facts.
- A complete, detailed, contemporaneous and signed record should be maintained.
- Copies of all correspondences with the patient's relatives and the police should be preserved.

We will conclude this module by referring to one more accepted principle in law i.e., **res ipsa loquitur** which means that 'the fact speaks for itself', meaning wise, things are so obvious in the case and a decision can be given based on that, by the court.

**Master P.M. Ashwin v. M/S M. Hospital & others, 1997(1) CPR 393, Karnataka (SCDRC).** During Herniotomy, infant sustained cautery burns over lower limbs—doctrine of *res ipsa loquitur* (the fact speaks for itself) applied—negligence held—The State Commission held that such an accident would not happen if proper care was taken. The plastic surgeon who treated him for the burns, stated that he could not describe the great agony and pain suffered by the infant during the period of his treatment. The State Commission held the managing director and the medical director of the hospital vicariously liable and ordered them as well as the surgeon and the Anaesthesiologist to pay compensation of Rs. 5 lacs jointly and severally.

## SELF CHECK QUESTIONS:

# 04

## Operation room management

---

### INTRODUCTION

OT should be organized from the perspective of a patient whose surgical services are to be met. The aspirations of not only the patients but also the surgeons are always for a safe and infection free surgery so that recovery is faster, and healing is quicker. It is a highly sensitive place especially during surgery as critical organs are exposed to environment and there are at least three to four people operating and/or assisting. Therefore, it becomes more prudent not only for surgical room but for the entire OT complex, that the chances of infection are minimized. Minimal infection rates are not only dependent on the infrastructure but are also affected by desired range of temperature, humidity, number of air exchanges per hour, UV radiated pass box, laminar flows, air suction, variant air pressure gradients, decontamination and cleaning of various zones etc.

This is only possible if OT is systematically organized and is able to meet the requirements of operating surgeon, for a smooth, uneventful and infection free safe surgery. To fulfil these requirements, there are certain guiding principles which are briefly indicated below:

### GENERAL PRINCIPLES:

For efficient functioning of an Operation Theatre, following principles should be considered at planning level:

1. Every OT needs to be run with a zero tolerance for non-adherence of technical and infection prevention protocols, so maintaining discipline in OT is of prime importance.
2. Design and layout plan of an OT complex should be such that the complex is divided into four zones i.e. Protective, Clean, Sterile and Disposal zones, based on varying degrees of cleanliness/asepsis, and is maintained by a differential decreasing positive pressure ventilation gradient from the inner zone to the outer zone.
3. Entry of patients and staff should be restricted and only those who are on duty or called for by the OT staff are allowed to enter the complex. Entry and exits should always be through the defined routes only.
4. Any OT staff once entered in the complex should leave it only after off duty except those who are required to accompany the patients for provision of medical care and services. However, any OT staff if re-entering the OT complex will have to follow the protocols of the OT every time, including change of shoes, dress, decontamination of hand etc.
5. Every staff in OT has to follow the defined infection prevention protocols since keeping the operating room and its adjoining corridor sterile is one of the most important interventions to prevent infections in OT.
6. Cleaning protocols of various zones is very critical, in which the bacteriological count progressively diminishes from the outer to the inner zones (operating area). The protocol of cleaning various zones shall be such that in every changing zone/passage the quality of cleaning as per the higher

zone shall be applicable.

7. Supply and logistics for OT should be replenished only during off hours preferably when surgeries are not in progress. In no circumstance, patients/attendants should be asked to bring consumables, drugs etc. for any surgical procedure.
8. Temperature, humidity, number of air exchange per hour, maintaining positive pressure ventilation, each operating room with dedicated Air Handling Units, decontamination and sterilization of equipment and linen, regular and timely disposal of Biomedical waste, adherence to cleaning protocols etc. are the key activities which need to be monitored daily.
9. Before undertaking any surgery, the surgical and anaesthesia trolley should be ready and WHO surgical checklist should be adhered to.
10. Quality assurance for the entire complex must be as per the process defined in Government of India guidelines. All SOPs for clinical protocols and pre-post-surgical documentation are other important parameters for ensuring quality.

## **PATIENT CARE FROM PRE-OPERATIVE STAGE TO POST-OPERATIVE STAGE:**

### **Pre-op care at ward:**

Routine pre-operative and pre anaesthetic preparation will be carried out here. This includes taking informed consent, investigations, pre medication, skin preparation, securing IV line, urinary catheterization etc. The test results are assessed so that they are in congruence with the surgical and anaesthetic expectations.

### **Care in pre-op room:**

The patient is shifted to pre op room only after ensuring that all the protocol is followed and bed head tickets issued. Medication will be adjusted as per the suggestions of surgeon and anaesthetist.

### **Within the OT complex:**

#### **Shifting of patient to the OT:**

In OT, before the doctors and the patient enter, the OT nurse should keep the tray ready. For ensuring surgical safety before induction of anesthesia, the WHO checklist can be used by nurse, anaesthetist and surgeon. The OT nurse to ensure patient gets shifted from pre/post-operative room to another trolley designated for use in the protective zone (first trolley change). Patient's case sheet is handed over to the nurse on duty or OT receptionist.

#### **Pre-surgical preparation in the operating room:**

Only assigned persons like doctors, nurses, etc. are permitted entry to the operating room. All of them change slippers, surgical scrub, gown, mask etc. and then only enter. Surgical site is prepared and anxiety of the patient is addressed.

#### **Post-surgical practices within the operating room:**

Post-surgery, all equipment are segregated into different baskets, linen and sent to disposal corridor through pass box. Those which require disposal are sent back to the Bio Medical Waste room for further disposal and those which can be reused are sent to CSSD or TSSU for decontamination and sterilization.

- Administration of non-particulate antacid (30 ml 0.3 M sodium citrate) 30 minutes before surgery increases the gastric pH.
- Use surgical safety checklist for every surgery (Annexure 1).

## INFRASTRUCTURE PROTOCOL:

There are four zones in the OT complex, the bacteriological count of which decreases progressively from outer to the inner zone and the ventilation pressure gradient differentially decreases from inner to outer zone. If the infrastructural requirements are placed properly, then it becomes easy to monitor the quality of services.

### Other important infrastructural Considerations:

- Temperature of OT should be adjusted between 21 degree Centigrade +/- 3 degree Centigrade according to requirement of patient, especially in paediatric, geriatric, burns, neonatal cases etc.
- Relative humidity of 20-60% to be maintained though the ideal RH is considered to be 55%.
- Every operating complex in OT should have separate AHU. All AHU should be switched on one or two hours before surgery.
- Morning routine cleaning and decontamination should take place at least one hour before surgery.
- Any staff entering into a clean and sterile zone should change his shoes before entering clean zone and should change slippers before entering sterile corridor.
- OT nurse in charge should ensure readiness of surgical anaesthesia and emergency drug trolley before operating team and anaesthetists arrive in operating room.
- Before entering the operating room, surgical scrub is essential.
- The nurse in charge of pre op room would check and ensure that doctor's direction on the previous day has been ensured by the ward nurse and patient has been prepared for undergoing surgery.
- Alcohol rub and hand wash facility should be provisioned for at the time of shoe/slipper change.
- When the patient arrives in the operating room, WHO safety checklist has to be ensured.

## QUALITY MAINTENANCE:

OT should be maintained in such a way that the rate and incidence of the quality indicators should be as minimum as possible. The average expected rate of Surgical Site Infections is 3-15% after caesarian section. Other risk factors such as obstetric complications and high contamination which are common in low and middle income countries can increase this infection rate. However, there could always be factors like immunity of the patient and other associated factors which can lead to complications, adverse events and increase in infection rate. The ultimate quality of OT is to be monitored through the quality indicators like:

1. Practice of WHO safe surgery checklist in the OT
2. Report on any Anaesthesia / surgery complications
3. Number of adverse events per thousand surgeries
4. Surgical site infection Rate (as a % of major surgeries)
5. Incidence of re-exploration surgeries

6. Percentage (%) of culture test reported positive (air sampling, settle plate<sup>1</sup>)
7. Number of autoclave cycles failed in Bowie dick test out of total autoclave cycle
8. CSSD/TSSU productivity index
9. Downtime of critical equipment used in OT should be up to 5%. There should always be backup available to ensure 100% functionality of OT. Every OT should measure downtime for Anaesthesia equipment, Defibrillator, Autoclave, functionality of pendants, C-arm, cryosurgery units and slit lamp. (Any other critical equipment can be added)
10. Apart from above mentioned critical equipment, downtime of remaining critical equipment should not be more than 5% in a year or should not be more than 1.5 days in 1 continuous stretch.

---

1. <https://www.ncbi.nlm.nih.gov/pmc/articles/PMC3275863/>

# ANNEXURE 1:

## Surgical Safety Checklist

Before Induction of Anaesthesia

*(with at least nurse and anaesthetist)*

**Has the patient confirmed his/her identity, site, procedure, and consent?**

Yes

**Is the site marked?**

Yes

Not applicable

**Is the anaesthesia machine and medication check complete?**

Yes

**Is the pulse oximeter on the patient and functioning?**

Yes

**Does the patient have a:**

**- Known allergy?**

No

Yes

**- Difficult airway or aspiration risk?**

No

Yes, and equipment/assistance available

**- Risk of >500ml blood loss (7ml/kg in children)?**

No

Yes, and two IVs/central access and fluids planned

Before Skin Incision

*(with nurse, anaesthetist, and surgeon)*

**Confirm all team members have introduced themselves by name and role.**

**Confirm the patient's name, procedure, and where the incision will be made.**

**Has antibiotic prophylaxis been given within the last 60 minutes?**

Yes

Not applicable

**Anticipated Critical Events**

**To Surgeon:**

What are the critical or non-routine steps?

How long will the case take?

What is the anticipated blood loss?

**To Anaesthetist:**

Are there any patient-specific concerns?

**To Nursing Team:**

Has sterility (including indicator results) been confirmed?

Are there equipment issues or any concerns?

**Is essential imaging displayed?**

Yes

Not applicable

Before Patient Leaves Operating Room

*(with nurse, anaesthetist, and surgeon)*

**Nurse Verbally Confirms:**

The name of the procedure

Completion of instrument, sponge, and needle counts

Specimen labelling (read specimen labels aloud, including patient name)

Whether there are any equipment problems to be addressed

**To Surgeon, Anaesthetist and Nurse:**

What are the key concerns for recovery and management of this patient?

The Checklist is not intended to be comprehensive. Addition and modification to fit local practice are encouraged.



## ANNEXURE 2:

### Important Equipment:

- i. Resources for airway management
  - Laryngoscope and assorted blades.
  - ET tubes with stylet.
  - Suction source with tubing and catheter.
  - Medication for hypnosis, relaxation and blood pressure support.
  
- ii. Resources for difficult airway management
  - Rigid laryngoscope blade.
  - ET tubes of different size.
  - LMA/ i - JEL
  - Jet ventilation/cricothyrotomy unit with TTJV
  - Combitube
  - Semirigid stylet
  - Equipment for emergent surgical airway
  - Topical anaesthesia and vasoconstrictor
  - Fibreoptic bronchoscope
  
- iii. Resources For Obstetric Haemorrhagic Emergency
  - Large bore i/v cannula.
  - Fluid warmer
  - Forced air body warmer
  - Blood bank resource
  - Pressure bags and automatic infusion device

### Monitoring equipment

- i. Maternal monitoring
  - ECG
  - Blood pressure (non-invasive)
  - Pulse oximetry
  - Temperature
  - Capnography
  
- ii. Foetal Monitoring
  - Foetal heart rate

## CLEANING PROTOCOLS FOR OT FOR DIFFERENT ZONES

Activities	Frequency	Agent Used
<b>Cleaning should start from innermost zone to outermost zone.</b>		
<b>Sterile Zone</b>		
Operation Theatre floor	Morning, evening, after every surgery and as and when required	Damp Mop with detergent and water followed by disinfection with 0.5% chlorine
Mopping (Care to be taken in case of special epoxy flooring)	Morning, evening, after every surgery and as and when required	Damp mop with detergent and water followed by disinfection with 0.5% chlorine
OT table and OT stretcher	Morning, evening, after every surgery and as and when required	Clean with swab dipped in soap water. Let it dry and then disinfect with 0.5% chlorine/70% Isopropyl Alcohol. Disinfect the swab separately in chlorine solution
Instruments	After every surgery	De-contaminate the instruments before cleaning with detergent. Alternatively, use zipper bags (re-usable and autoclavable) for keeping the instruments before sending to CSSD for decontamination and sterilization. Use a leak proof and puncture covered container for transport to CSSD.
Sterile corridor	Morning, evening and every two hours	Damp Mop with detergent and water followed by disinfection with 0.5% chlorine
Equipment like Anaesthesia machines, monitors, ventilators, infant warmers/baby cribs etc. or other equipment/furniture.	After each procedure/as & when required, whether used or not in last 24 hours	Damp Mopping, dry followed by disinfection with 70% isopropyl alcohol. Monitor screen should not be mopped with any solvent. Cleaning of these screens should be done as per recommendations.
<b>Clean Zone</b>		
Doctor's/nurses/ technician room	Morning, evening, and as and when required	Detergent & water
Washroom & wash basins	Morning, evening, every 2 hours and as and when required	Wash with detergent & water, then dry, disinfect with 0.5% chlorine
Store rooms	Morning, evening, and as and when required	Detergent & water

Clean corridor	As per sterile zone cleaning frequency i.e. Morning, evening and every two hours	Damp Mop with detergent and water followed by disinfection with 0.5% chlorine
Pre and Post-operative recovery room	4 Times a day including morning and evening	Damp Mop with detergent and water followed by disinfection with 0.5% chlorine
Pantry	4 Times a day including morning and evening	Detergent & water
Slippers	Once a day and as and when required	Detergent & water
Shoe change area	Once a day	Detergent and water
<b>Protective Zone</b>		
Protective corridor	Morning, evening, and once in two hours	Damp Mop with detergent and water followed by disinfection with 0.5% chlorine
Trolley wash	Clean after each use if not in use, once a day	Damp mop with detergent/alcohol and water
Mops	After every use	Soak in chlorine solution (0.5%) for 30 minutes. Wash again with detergent and water to remove the bleach
<b>Disposal Zone</b>		
Disposal corridor	Morning, Evening and as and when required.	Damp Mop with detergent and water followed by disinfection with 0.5% chlorine
Dirty Utility room	Morning, Evening and as and when required.	Damp Mop with detergent and water followed by disinfection with 0.5% chlorine
Bio Medical Waste Management	Thrice a day and when bags are 3/4th full present in Dirty Utility area	As per BMW rules, 2018
Fumigation	Routine fumigation is not recommended but may be done under special circumstances such as after construction/renovation and/or major civil and maintenance work, while commissioning new OT or reporting of any infection in the OT.	Agent recommended: Hydrogen peroxide or combinations of silver nitrates (depending on the availability in the market). *use of aldehyde containing compounds e.g. Formaldehyde is contraindicated in hospitals.



# Week 2 - Module

## Anatomy, Physiology & Pre Anesthesia Checkup



# 05

## Anatomy including Airway Anatomy relevant to Anaesthesia

---

### INTRODUCTION:

A quarter of preventable deaths related to anaesthetics are due to airway mismanagement; hence assessment of airway preoperatively goes a long way in preventing such mishaps. Inclusion of this module in this curriculum has been done in order to train you, people, to identify a difficult airway preoperatively and to be ready for unanticipated difficult intubation. A delay in intubation in a pregnant patient may lead to the poor outcome of the infant. Pregnancy being an additive factor for the difficulty in intubations, you have to be very careful in determining the grade of difficulty preoperatively.

### OBJECTIVES:

After going through this module, you should be able to:

- Understand the basic anatomy of the airway
- Describe the method of evaluation of the airway.
- Describe how to diagnose a difficult airway and to weigh the advantages of proceeding for anaesthesia at the FRU.
- Describe the airway adjuncts available and their usage.
- Describe the technique of intubation and difficult intubation drill.

### SKILLS:

- Mask ventilation.
- Laryngoscopy and tracheal intubation.
- Supraglottic airway device (LMA) insertion.

### ANATOMY OF THE AIRWAY:

The airway can be divided in to

- a. Upper airway- Nose, mouth, nasal cavity, paranasal sinuses, pharynx and larynx.
- b. Lower airway- Trachea, bronchi, bronchioles, alveolar ducts and alveoli.

Airway begins at the nostril. The nose can be divided into two regions- external nose and internal nasal cavity



Alae nasi are lateral margins of the nostrils. Flaring of ala nasi indicates airway obstruction or respiratory distress. Distance from alae nasi to tragus or external auditory meatus is used for oropharyngeal airway size selection and temperature probe insertion.

The nasal cavity humidifies, warms, filters, and acts as a conduit for inspired air. About 10,000L of air passes through the nose every 24 hours. Great vascularity of the nose help in maintaining the constant temperature of the gases. Source of humidification is from transudation of fluid through mucosal epithelium, secretory glands and goblet cells. The daily volume of nasal secretions about 1 L, three fourth of which is used in saturating the inspired air. Tracheal intubation & high fresh gas flow bypasses this humidification system, making use of HME (heat moist exchanger) filters necessary. Prolonged exposure of lower respiratory tract to this non humidified air leads to dehydration of mucus, altered ciliary function, inspissation of secretion, atelectasis and ventilation-perfusion mismatch.

The mucosa of the nose and the posterior pharyngeal wall is very vascular and may easily be torn, so, force should not be used during their manipulation. Tearing through mucosa may lead to the passage of the tube into retropharyngeal space. Injury to posterior ethmoidal vessels (Woodruff's plexus) may lead to serious haemorrhage.

**Pharynx** - Pharynx starts at the base of the skull and extends up to the inferior border of cricoid cartilage (c6 vertebrae). It is 12-14 cm long and 3.5cm wide at its base. Its width is 1.5cm at a pharyngoesophageal junction, which is the narrowest part of the digestive system.

Posterior pharyngeal wall is made up of buccopharyngeal fascia which separates pharyngeal structures from retropharyngeal space. Improper and forced placement of gastric or tracheal tube can result in laceration of this fascia.

**Nasopharynx** - Extends from posterior nasal aperture to the posterior pharyngeal wall above the soft palate. The area, where it ends at soft palate is called velopharynx and is common site for airway obstruction in both awake and anaesthetised patient. Roof of nasopharynx is at acute angle with the posterior pharyngeal wall, which can be straightened by extension of the head to facilitate the passage of any nasal tube.

**Oropharynx** - extends from soft palate to epiglottis and also includes tonsil, uvula & epiglottis.

Mallampatti classification is based on visualisation of the soft palate, fauces, uvula, tonsillar pillars in the oral cavity with relation to the tongue.

Airway obstruction during sleep, decreased consciousness, and general anaesthesia is caused by collapsible soft tissue around the pharynx. Jaw thrust & neck extension helps to create space between the epiglottis & posterior pharyngeal wall. Laryngoscope blade tip lies in vallecula (a space between epiglottis & base of tongue) during classical Macintosh laryngoscopy.

Increase in soft tissue within a bony enclosure of pharynx or decrease in bony enclosure size would result in anatomical imbalance and cause limitation of space available for airway.

Larynx- lies opposite C3 to C6 vertebra in adult & C1 to C4 vertebra in children.

Average measurements of the larynx in adult female:

	Length
Vertical length	36 mm
Transverse diameter	41 mm
Anteroposterior diameter	26 mm

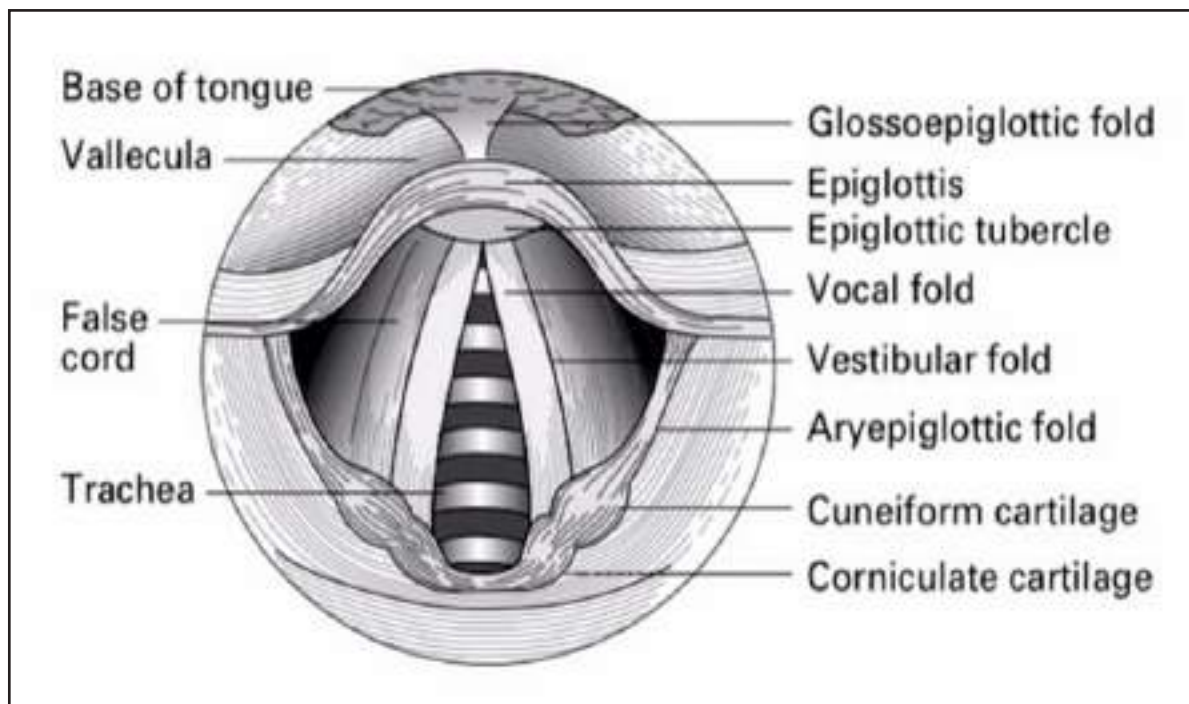


Figure showing laryngeal view at laryngoscopy- Cormack Lehane grading is based on this.

The larynx contains nine cartilages- 3 unpaired (Thyroid, Cricoid, Epiglottis) and 3 paired (Arytenoid, Corniculate, Cuneiform).

BURP (Backwards Upwards Rightwards Pressure) and OELM (optimum external laryngeal) manoeuvres are used to improve the view of the glottis during laryngoscopy and tracheal intubation.

Sellick's Maneuver is downward pressure applied over cricoid cartilage to prevent passive regurgitation.

### Intrinsic muscles of the larynx :

- a. Those acting on the vocal cord
  - Abductor – Posterior crico arytenoid
  - Adductor – Lateral crico arytenoid Transverse & oblique arytenoid
  - Tensor (Elongation) – Cricothyroid, partly Vocalis
  - Relaxor (Shortening) – Thyroarytenoid, partly Vocalis
- b. Those acting on laryngeal inlet
  - Openers- Thyroepiglotticus, thyroarytenoid
  - Closer – Aryepiglotticus, oblique arytenoid

### Innervation of the larynx

Sensory supply –

Glottis, supraglottis, and inferior epiglottis- Internal branch of Superior laryngeal nerve (SLN)

Subglottis- Recurrent laryngeal nerve (RLN)

Tongue base and vallecula- Glossopharyngeal nerve



Motor- RLN supplies all intrinsic muscles of the larynx (except cricothyroid). Cricothyroid is supplied by the external branch of SLN. External branch of SLN and RLN may get damaged during thyroid surgery.

## Trachea

- Extends from C6 (cricoid cartilage) to the carina (T4–T5).
- In adults its length is 11–13 cm, with 2–4 cm being extra thoracic.
- Mean anteroposterior diameter of trachea is 20 mm and the mean transverse diameter is 17 mm in adults.
- The trachea has 16 to 22 horseshoe bands (c shaped) of cartilages.
- Posterior tracheal wall lacks cartilage and is supported by the trachealis muscle.
- Depending on the level of inspiration, the posterior wall of the trachea becomes flat, convex or slightly concave.
- Trachea divides into right and left main stem bronchi at the level of T5 and (Louis angle of the sternum). Right bronchus takes off at an angle of 25°, while left at an angle of 45° from the carina.
- Normal tracheal bifurcation/ carinal/ subcarinal angle- 60° (40–90°).
- Right main bronchus is shorter (2.2 cm in length compared to 5 cm of left main bronchus), broader (15 mm compared to 13 mm of left), straighter and more in line with trachea in adults. That is why aspiration is more common on the right.

### i. Pregnancy Induced Changes:

- Generalised weight gain.
- Increase in breast size.
- Respiratory mucosal oedema and friability.
- Increased risk of aspiration.
- Reduced chest compliance.
- Reduced O<sub>2</sub> reserve.
- Drugs like MgSO<sub>4</sub>, Narcotics.

### ii. Basic technique of laryngoscopy

Successful and proper exposure of the glottic opening using direct laryngoscopy requires an alignment of the oral, pharyngeal and laryngeal axes, which is accomplished by elevation of the patient's head by 8-10 cm using a ring or a pillow under the occiput and extension of the head at the atlantooccipital joint. This is described as the "sniffing position".

**Retraction of tongue to left side with laryngo scope blade**



**Introduction of laryngoscope blade into oral cavity**

**Optimising position of head traction on laryngoscope  
Handle (Not levering on the upper incisors)  
To obtain view of larynx**



**Tip of laryngoscope blade fits into the Vallecula**

# 06

## Physiologic changes during Pregnancy

### INTRODUCCION:

- ◇ The obstetric anaesthesia caregiver has the responsibility of two lives; this is increased by the fact that pregnancy is a state of altered physiology, so it is necessary to have a good understanding of how pregnancy and labour alter maternal physiology and ways in which these changes may have an effect upon and be affected by anaesthetic procedures and anaesthetic agents.
- ◇ Important issues to be considered while anaesthetising a pregnant woman for labour, vaginal delivery, or caesarean delivery are:
  - **Physiological changes in pregnancy**
  - **The direct and indirect effects of anaesthetics on the foetus**
  - **The benefits and risks of various anaesthetic techniques to the mother**

In this module, the anaesthesiologist will learn about these issues.

### OBJECTIVES:

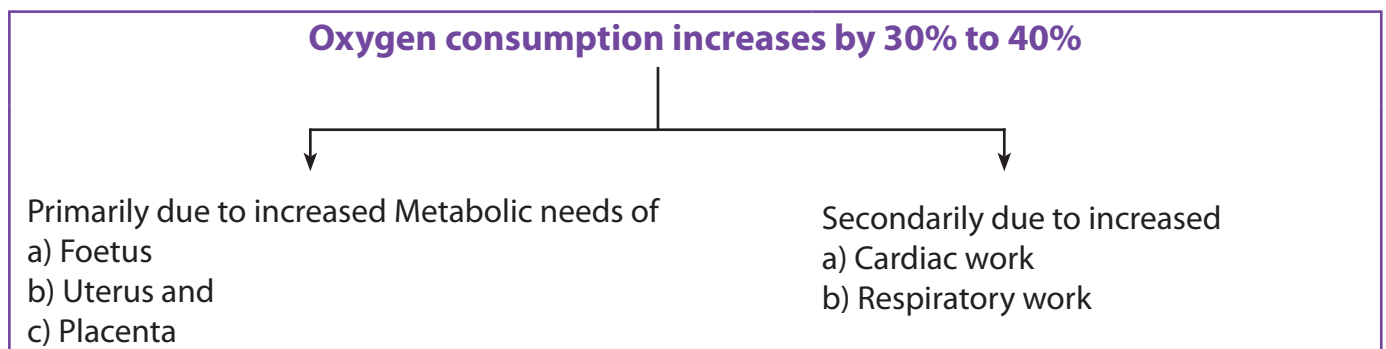
After going through this module, you should be able to

- Describe physiological changes in pregnancy.
- Describe anaesthetic implications of these changes.

### \* **BODYWEIGHT AND COMPOSITION**

- Increase in mean weight = 17% of Pre-pregnant weight or approximately 12 kg.
- Amniotic fluid = 1kg.
- Uterus = 1kg
- Foetus and Placenta = 4kg.
- Blood volume = 2kg.
- Interstitial fluid = 2kg.
- Deposition of new fat and protein = 4kg
  - Normal weight gain (approximately) during
    - 1st trimester = 1-2kg.
    - 2nd trimester = 5-6kg.
    - 3rd trimester = 5-6kg.

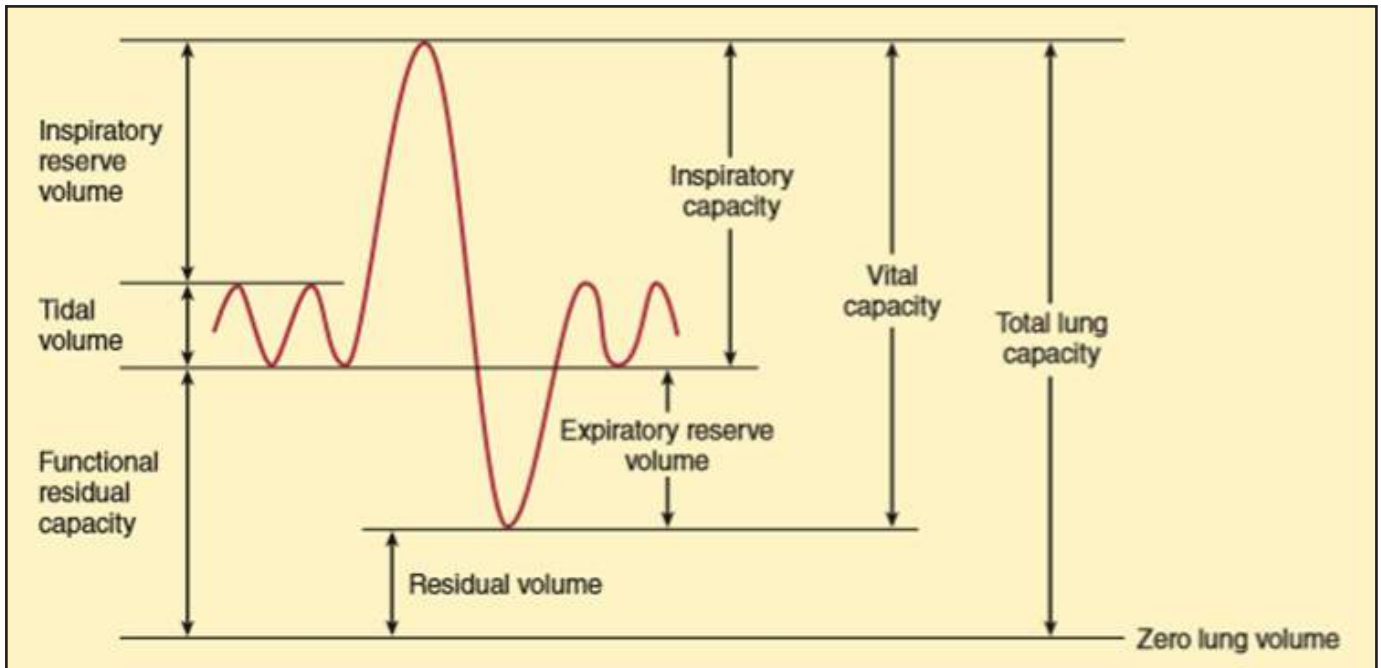
## \* METABOLISM



## \* RESPIRATION

### i. Lung Volumes:

- Tidal volume (TV) is the volume of air inhaled or exhaled during normal quiet breathing.
  - Normal TV is 500 ml.
- Inspiratory reserve volume (IRV) is the maximal volume of gas that can be inhaled following a normal inspiration while at rest.
  - Normal IRV is 3000 ml.
- Expiratory reserve volume (ERV) is the maximal volume of gas that can be exhaled following a normal expiration.
  - Normal ERV is 1000 ml.
- Residual volume (RV) is the volume of gas remaining in the lungs after a forced exhalation.
  - Normal RV is 1500 ml.
- Vital capacity (VC) is the maximal amount of gas that can be exhaled after a maximal inhalation.
  - $VC = TV + IRV + ERV$ .
  - Normal VC = 4500 ml.
- Inspiratory capacity (IC) is the maximal amount of gas that can be inhaled from the resting expiratory position after a normal exhalation.
  - $IC = TV + IRV$ .
  - Normal IC = 3500 ml.
- Functional residual capacity (FRC) is the remaining lung volume at the end of a normal quiet expiration.
  - $FRC = RV + ERV$ .
  - Normal FRC = 2500 ml.
- Total lung capacity (TLC) is the lung volume at the end of a maximal inspiration.
  - $TLC = VC + RV$ .
  - Normal TLC = 6000 ml.



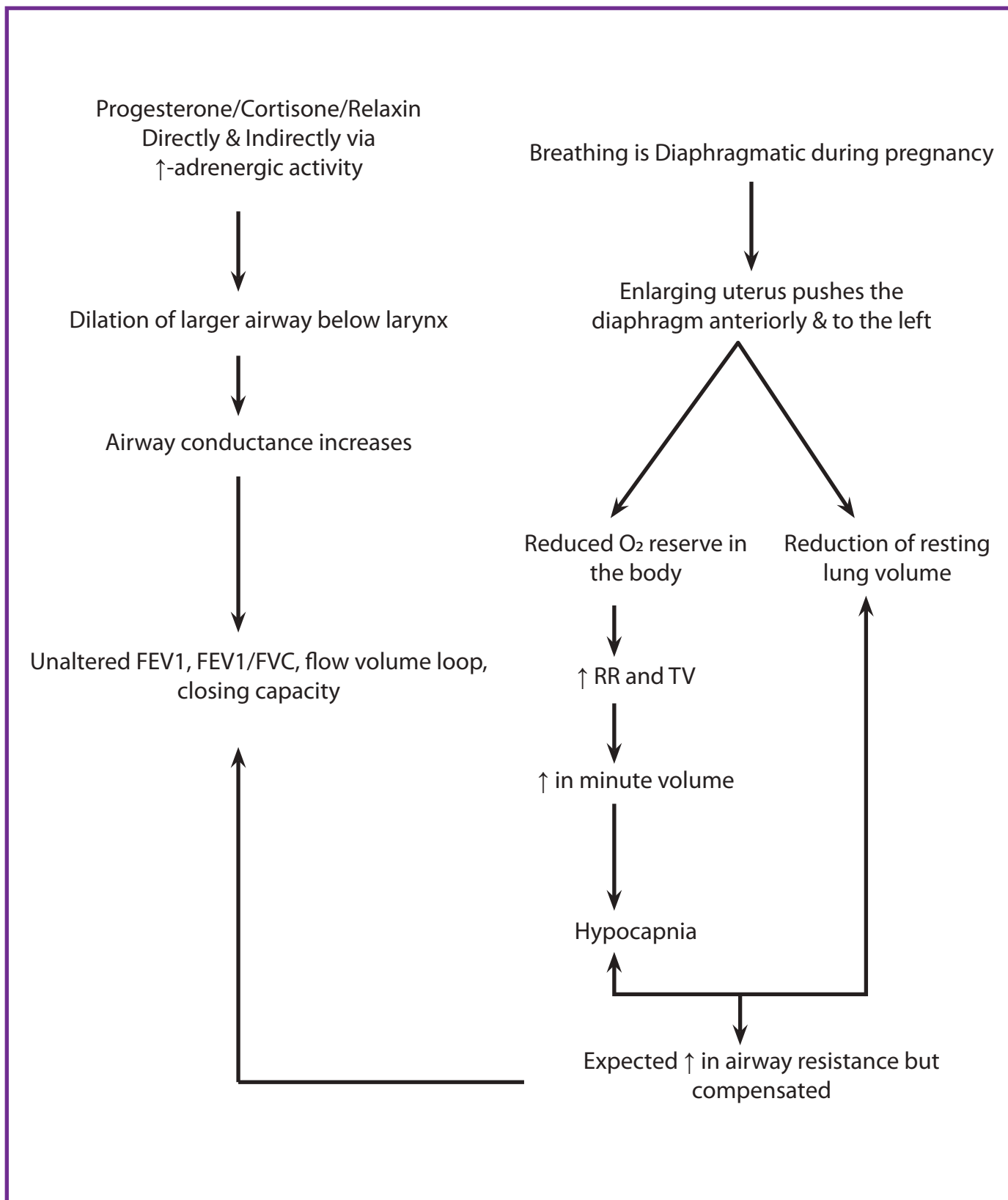
## ii. Respiratory mechanics

- Thoracic cage increases in circumference by 5 - 7cm in pregnancy because of increases in both the anteroposterior and transverse diameters.
- Capillary engorgement of the nasal and oropharyngeal mucosae and larynx begins early in the first trimester and increases progressively throughout pregnancy.

### Effects of pregnancy on Respiratory mechanics

Parameter	Change
Diaphragmatic excursion	Increased
Chest wall excursion	Decreased
Pulmonary resistance	Decreased by 50%
FEV1	No change
FEV1/FVC	No change
Flow volume loop	No change
Closing capacity	No change

## Role of Hormones – progesterone, cortisone and relaxin on Airway?



### iii. Changes in Lung Volumes and Capacities:

There are four basic lung volumes and 4 “derived capacities” which are combinations of these lung volumes.

Parameter	Change
Lung Volumes	
IRV	+ 5%
TV	+ 45%
ERV	- 25%
RV	- 15%
Lung capacities	
IC	+ 15%
FRC	- 20%
VC	No change
TLC	- 5%
Dead Space	+ 45%
Respiratory rate	No change

### iv. Ventilation:

Minute ventilation = increases by + 45%

Alveolar ventilation = increases by + 45%

- The increased ventilation during pregnancy results from hormonal changes and increased carbon dioxide production.
- Progesterone increases the sensitivity of the central respiratory centre to carbon dioxide and acts as a Direct Respiratory Stimulant.



## v. Blood gases:

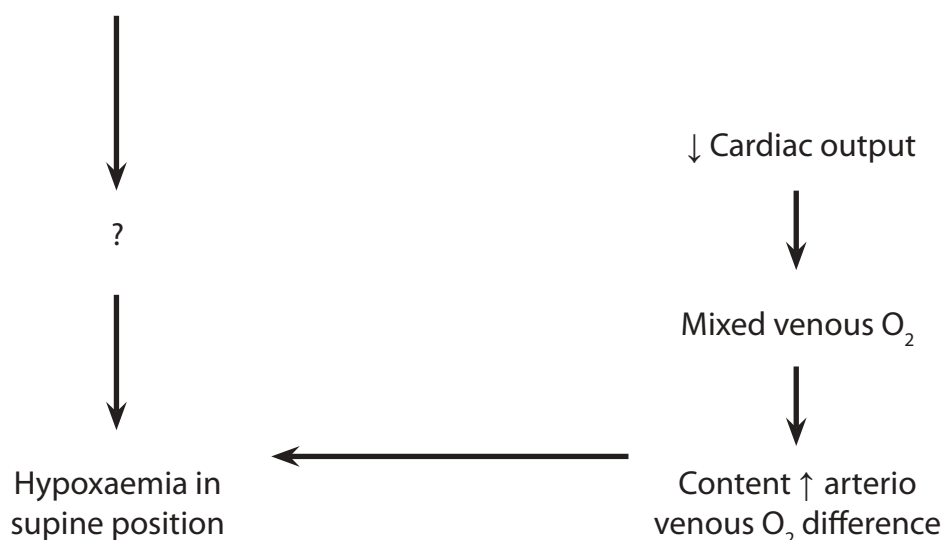
Blood Gases During Pregnancy				
Description	Nonpregnant	Trimester		
		First	Second	Third
PaCO <sub>2</sub>	40	30	30	30
PaO <sub>2</sub>	100	107	105	103
pH	7.40	7.44	7.44	7.44
HCO <sub>3</sub>	24	21	20	20

What happens to the gradient between end - tidal carbon dioxide tension and arterial partial pressure of carbon dioxide (PaCO<sub>2</sub>)?

- During early pregnancy, at term gestation and in the early postpartum period, the two measurements are equivalent (although a gradient exists in nonpregnant individuals) due to reduction of alveolar dead space (i.e. un-perfused alveoli), which results from a marked increase in cardiac output.
- A PaO<sub>2</sub> below 100 mm Hg aortocaval in supine position compression.

How does moving a pregnant woman from supine to erect or lateral decubitus position improves arterial oxygenation and decreases the alveolar arterial oxygen gradient?

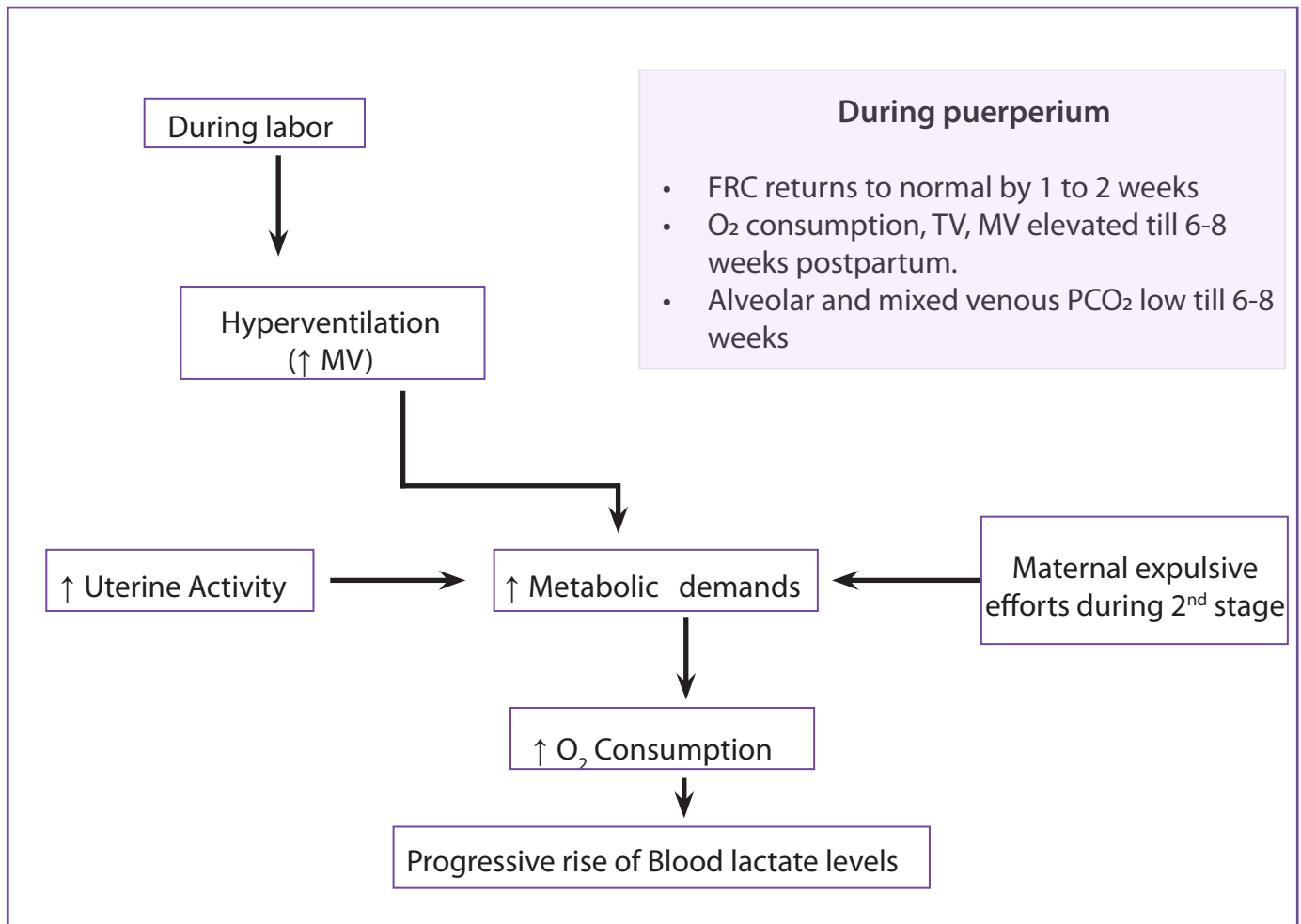
**Due to FRC < CC (Closing capacity) in upto 50%**



## vi. Acid-Base Balance:

Increase in respiratory rate, and tidal volume results in respiratory alkalosis and compensatory metabolic acidosis develops. Serum bicarbonate concentration becomes 20 mEq/L.

## vii. Metabolism and Respiration:



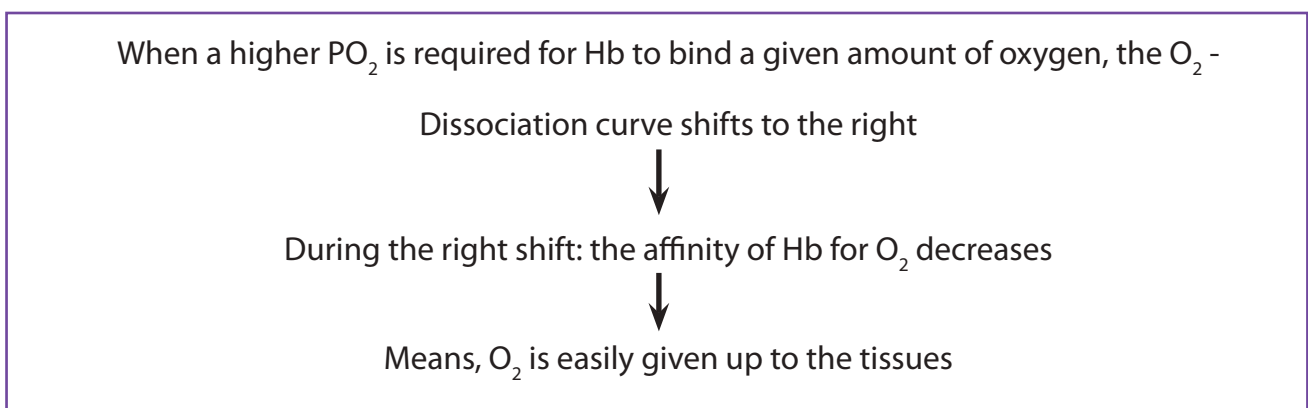
So, when opioid analgesia/epidural analgesia is administered during the first stage of labour, minute ventilation, O<sub>2</sub> Consumption, Lactate Concentration and PaCO<sub>2</sub> remain at near-normal values.

As normal physiology gets altered during pregnancy, we must note a few things regarding respiration during anaesthesia in a pregnant woman.

- Remember to "PRE-OXYGENATE". Or else the arterial O<sub>2</sub> tension will fall rapidly
- Securing the airway could be challenging and need expertise!

### How?

- There are increased chances of bleeding from nose or oropharynx due to increased vascularity
- May encounter difficulty in intubation due to mucosal oedema.
- Laryngoscopy may be difficult due to engorged breast.



$P_{50}$  is a convenient index of such shifts

What is  $P_{50}$ ?

It is the  $PO_2$  at which Hb is half saturated with  $O_2$ . The higher the  $P_{50}$ , the lower the affinity of Hb for  $O_2$ .

And when does this happen?

Right Shift occurs in:

- ↑ Temperature (as fever)
- ↑  $H^+$  (i.e. pH): acidosis/shock/diabetic ketoacidosis/lactic acidosis
- ↑ In 2, 3 DPG

### \* HEART AND CIRCULATION:

What is stroke volume?

It is the volume of blood pumped out by the heart in one beat.

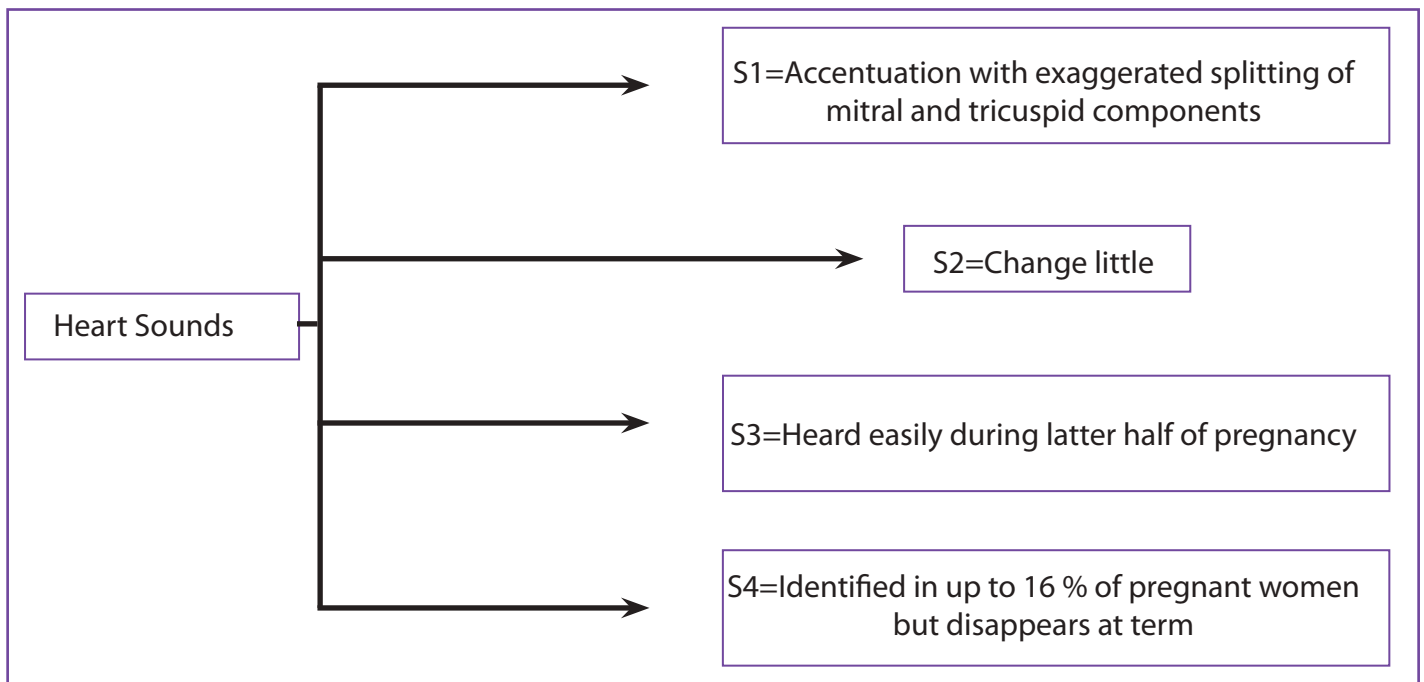
What is Cardiac Output?

It is the volume of blood pumped out by the heart in one minute

$CO = HR \times SV$ .

### i. Examination of the heart

- Elevation of the diaphragm shifts the heart anteriorly and to the left during pregnancy. Therefore, look for apical Impulse in the fourth intercostal space lateral to the mid-clavicular line



- Murmurs = a grade I or II early systolic to mid - systolic at the left sternal border due to dilatation of the Tricuspid Annulus resulting in regurgitation.
- ECG may reveal:
  - Sinus tachycardia.

- Shortening of P-R interval.
- QRS axis shifts to Right (During the first trimester)  
Left (During Third Trimester)
- T-wave axis shifted leftwards.
- Depressed S-T segment.
- Echocardiography.

Left ventricular hypertrophy by 12 weeks gestation (50% increase in mass) Aortic, pulmonary and mitral valve areas increase by 12-14%.

## ii. Central haemodynamic:

Prerequisites for accurate determination of hemodynamic changes of pregnancy:

- Measurement to be made in subjects in resting state
- Measurement to be made in position minimising compression of aorta and inferior vena cava by the gravid uterus

## Central Haemodynamics at Term Gestation

Parameter	Change
Cardiac Output	+ 50%
Stroke volume	+ 25%
Heart Rate	+ 25%
Left ventricular end-diastolic volume	Increased
Left ventricular end-systolic volume	No change
Ejection Fraction	Increased
Pulmonary Capillary wedge pressure	No change
Central Venous pressure	No change
Systemic Vascular resistance	- 20%

## iii. Organ perfusion:

- Uterus, kidneys and extremities (skin and skeletal muscles) receive more blood supply during pregnancy. Uterine blood flow increases to 700 – 800 ml/minute at term gestation.
- Blood flow to other major organs (e.g. Brain, liver) DOES NOT CHANGE.

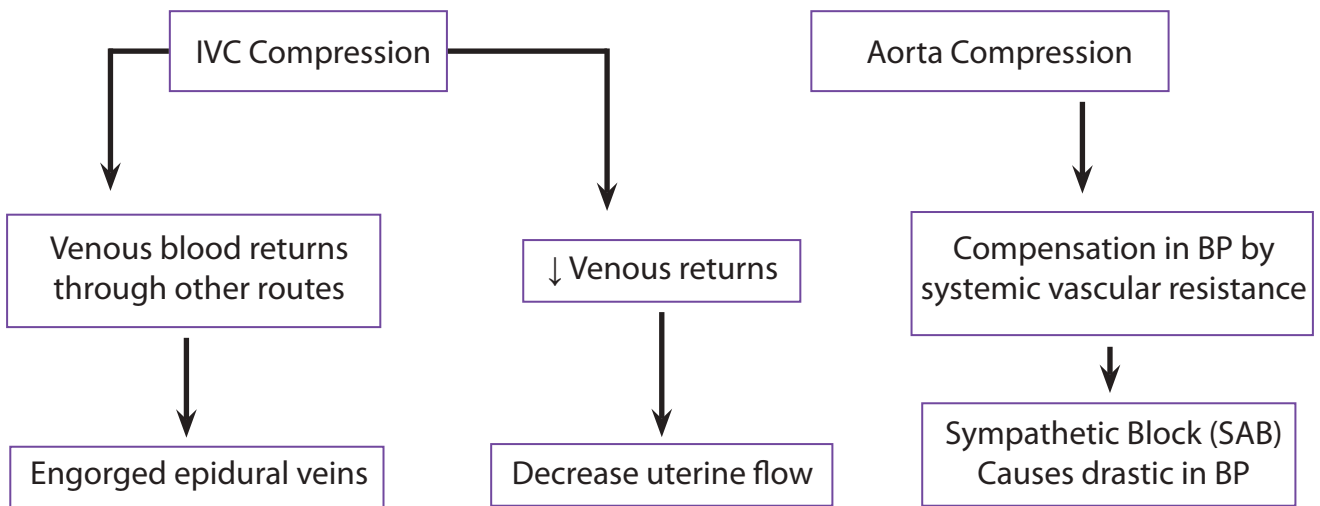
## iv. Blood pressure:

B.P. = CO x SVR (Systemic vascular resistance).

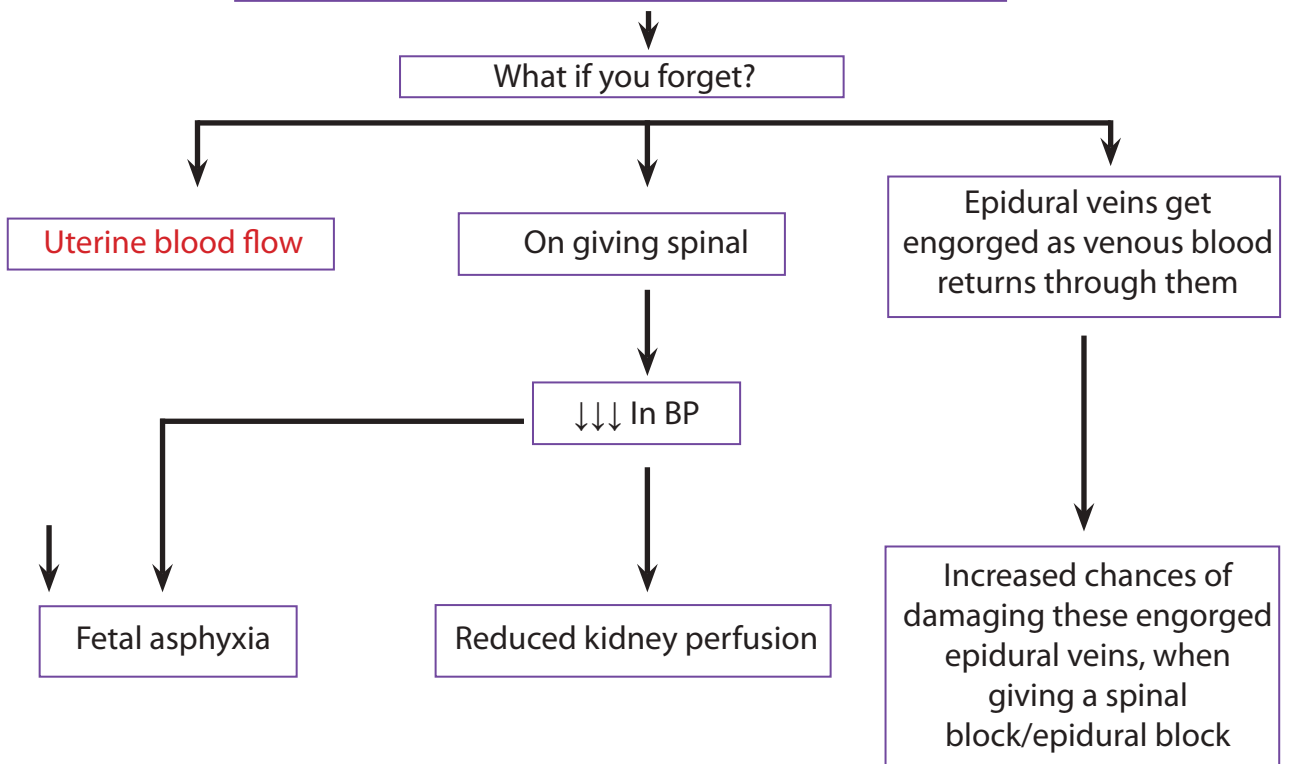
- Position/age/parity affect blood pressure measurement in pregnant women.
- Systolic BP minimally affected by pregnancy. Diastolic BP falls to a greater degree (than does systolic BP), i.e. may show a slight mid-pregnancy dip.

## A pregnant woman should not lie flat on her back

On lying flat, the enlarged uterus compresses the inferior vena cava (IVC) and lower aorta.



**SO, ALWAYS PUT A WEDGE UNDER THE RIGHT HIP!**



In pregnancy the requirements of local anaesthetic drug to be injected in spinal or epidural block is reduced. This is because, within the rigid spinal canal the increased venous volume reduces the effective volume of the extradural space.

So, the usual drug volume produces a greater height of block

More hypotension.  
 $\text{Blood Pressure} = \text{C.O.} \times \text{SVR}$   
 $= \text{SV} \times \text{HR} \times \text{SVR}$   
 $= \text{Venous return} \times \text{m. contractility} \times \text{HR} \times \text{SVR}$   
So, if there is hypotension, consider the following factors: -  
A. ↓ in venous return

1. This could be due to hypovolemia hemorrhage or Dehydration.

2. Due to intrathoracic pressure as in tension pneumothorax/IPPV/ PEEP.

3. Due to aortocaval compression as in intra-abdominal tumours.

#### B. Reduced Myocardial Contractility:

- This could be due to hypoxia, myocardial ischaemia or infarction, acidosis.
- Deep anaesthesia like halothane, beta-blockers.
- Tachy arrhythmias.
- Sepsis.
- Beta-blockers.

C. **Decrease in heart rate:** Halothane, Beta-blockers.

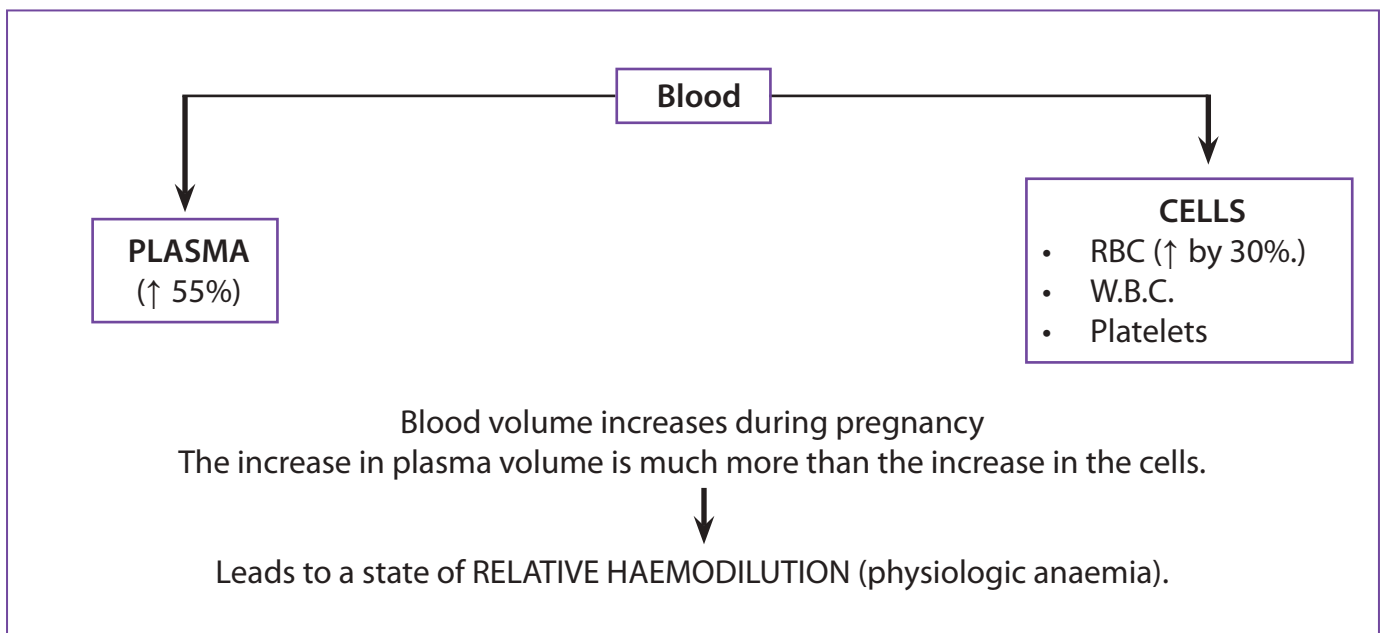
#### D. Decrease in systemic vascular resistance:

- Spinal anaesthesia – due to sympathetic blockade.
- Sepsis.
- Histamine release due to drugs.
- Anaphylaxis.

When BP falls, the SYMPATHETIC SYSTEM gets activated, to counter the fall in BP.

So, if contractility decreases, there is an increase in heart rate or ↑ in SVR to maintain BP. Similarly, if SVR falls due to peripheral vasodilatation – the heart rate increases.

## \* HEMATOLOGY AND COAGULATION:



This haemodilution helps to compensate for the maternal blood loss at delivery which is 300 to 500 ml in normal vaginal delivery and 750 to 1000 ml in a caesarean section.

Pregnancy represents state of accelerated but compensated intravascular coagulation.

### Changes in coagulation in fibrinolytic parameters at term gestation

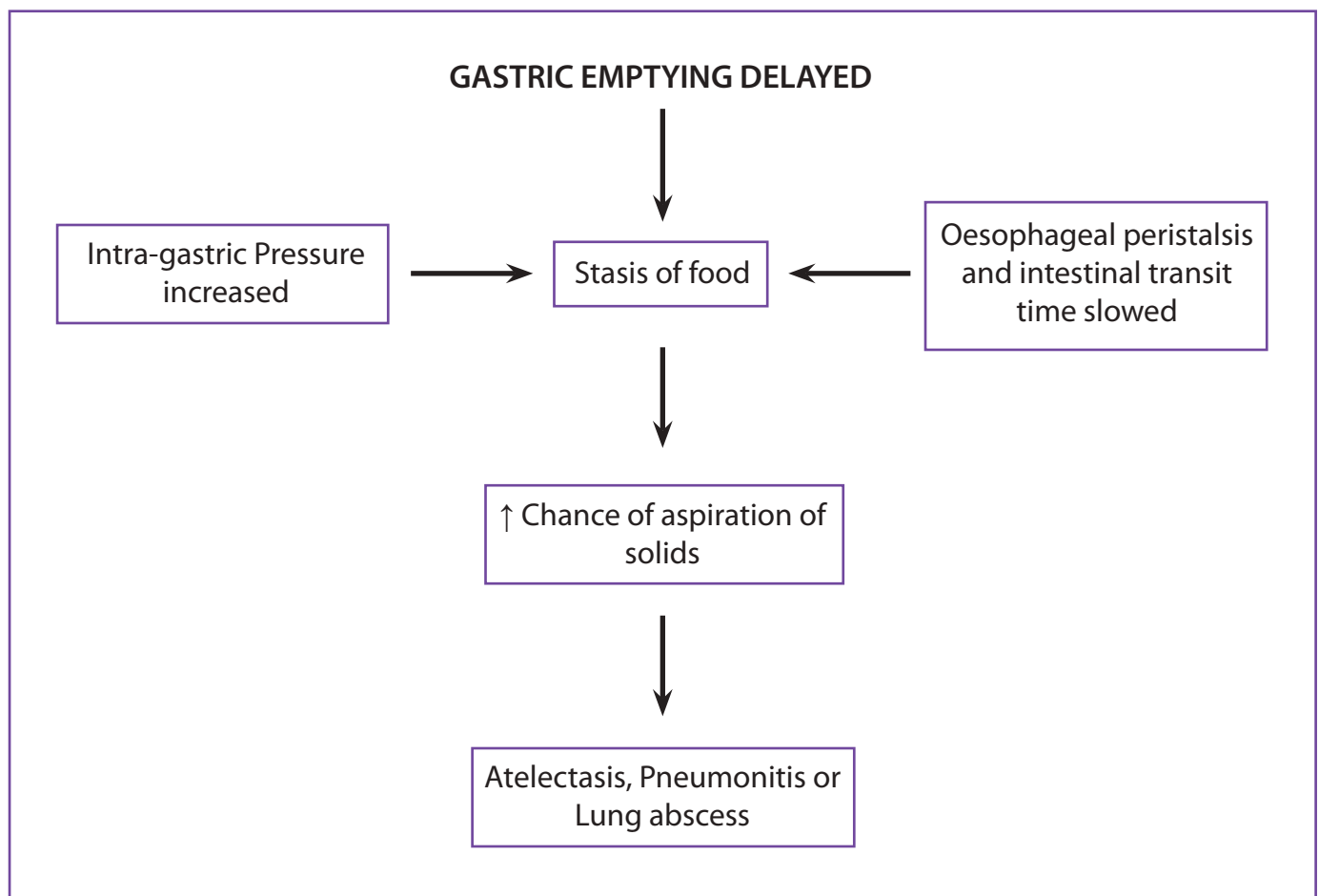
- Increased factor concentration:
  - Factor I (Fibrinogen).
  - Factor VII (Proconvertin).
  - Factor VIII (Antihemophilic factors).
  - Factor IX (Christmas factor).
  - Factor X (Stuart Prower factor).
  - Factor XII (Hageman factor).
- Unchanged factor concentrations:
  - Factor II (Prothrombin).
  - Factor V (Proaccelerin).
- Decreased factor concentrations:
  - Factor XI (Thromboplastin antecedent).
  - Factor XIII (Fibrin stabilising factor).
- Prothrombin time = -20% (shortened).
- Partial thromboplastin time = -20% (shortened).
- Antithrombin III = decreased.



- Platelet count = no change or decreased.
- Bleeding time = -10% (shortened).
- Fibrin degradation product = increased.
- Plasminogen = increased.

\* **GASTROINTESTINAL SYSTEM:**

Consider every pregnant woman to be full stomach second trimester onwards, so take adequate precautions thereafter



## Aspiration is more common in pregnant women

Enlarging uterus pushes stomach upwards into left side of diaphragm



Displaces intra-abdominal segment of esophagus into thorax



Gastro esophageal angle changes

+



Prevents rise in lower esophageal tone, which normally accompanies an increase in intra-gastric pressure.

Reduction in the tone of lower esophageal sphincter



All these factors increase the chances of reflux



The chances of acid aspiration increase



Chemical pneumonitis known as Mendelson syndrome  
Effects of analgesia during labour on gastric function



Opioids

++

Impaired gastric emptying + reduced tone of Lower Oesophageal high-pressure zone

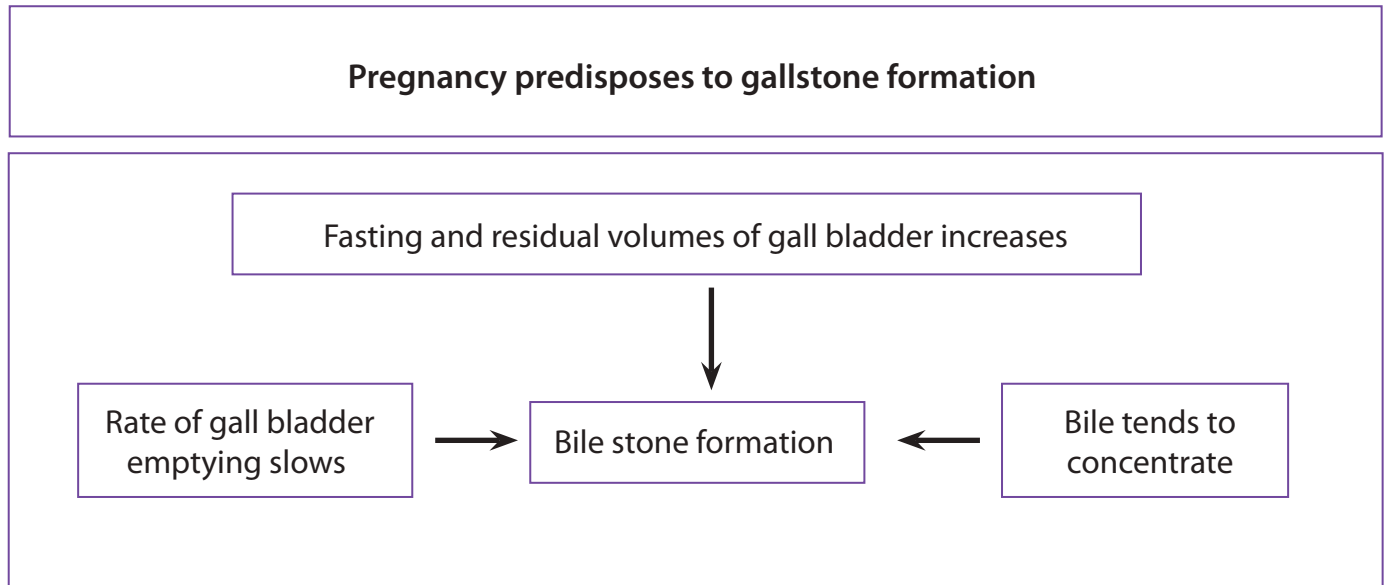
--

Epidural local anaesthetic

## Liver and gall bladder:

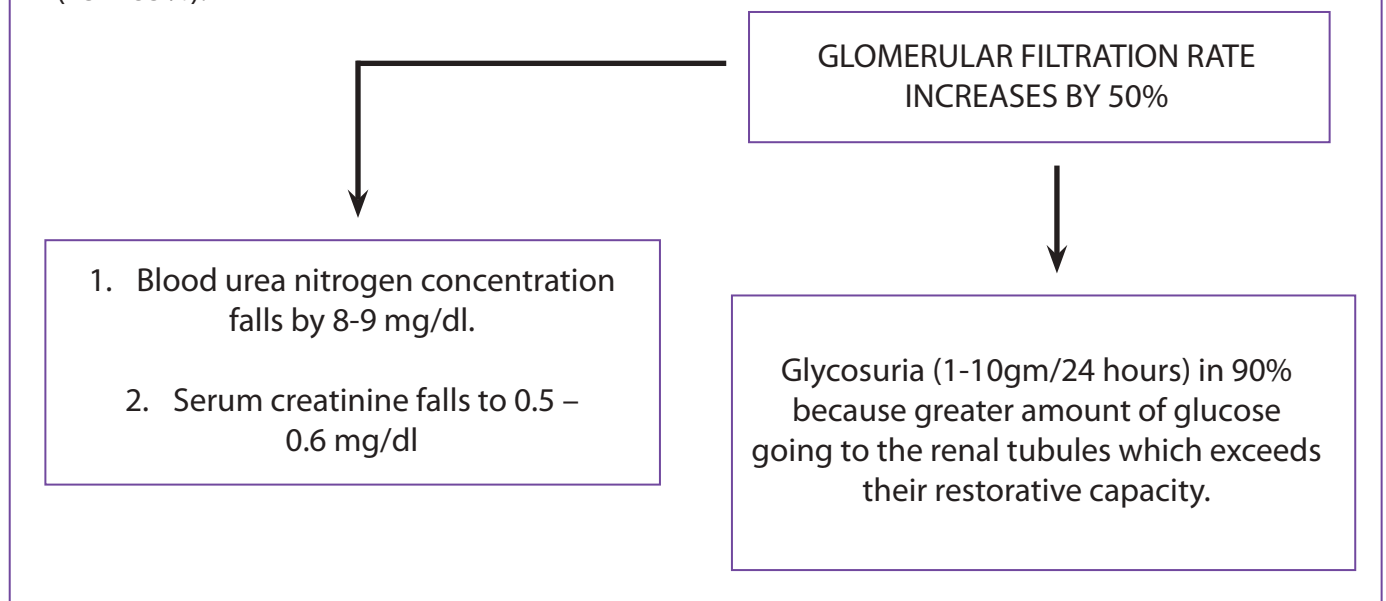
Liver size/morphology/blood flow do not change during pregnancy.

- Serum bilirubin/SGPT/SGOT/lactic dehydrogenase to upper limits of the normal range.
- Alkaline phosphatase activity increases 2–4 folds mostly from the production by the placenta.



## \* RENAL SYSTEM:

- Kidneys enlarge in size.
- Ureters and renal pelvis dilate.
- Filtration fraction decreases.
- Greater increase in renal plasma flow (75 – 85%).



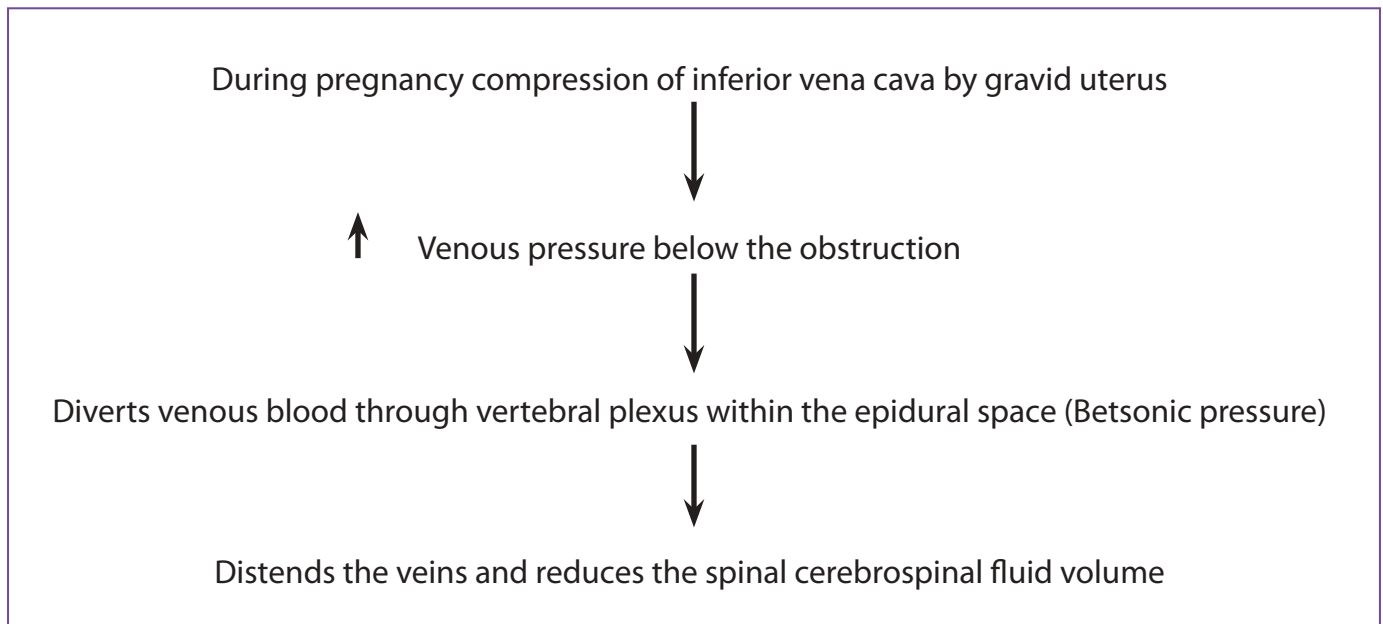
## \* NERVOUS SYSTEM:

### i. Pregnancy-induced analgesia:

The analgesic requirement is reduced in pregnancy due to the elevated threshold for pain during gestation; the role of endorphin (Specially  $\beta$ -endorphin implicated).

### ii. Vertebral Column:

Epidural space may be regarded as a rigid tube, which contains two fluid-filled structures, the Dural sac and the epidural venous plexus. When the volume within one distensible tube increases, there is the compensatory loss of fluid from the other.

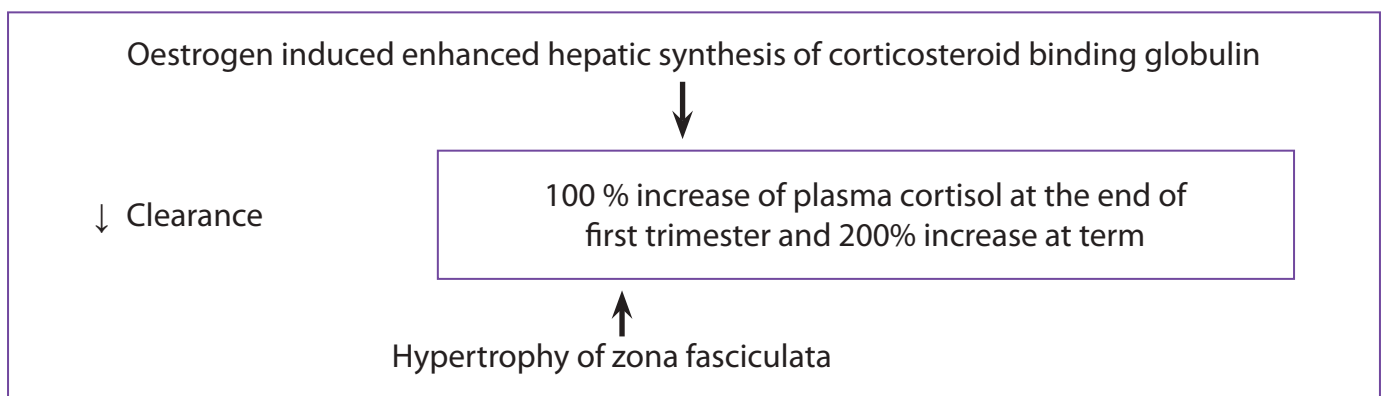


## \* ENDOCRINE SYSTEM:

### i. Thyroid function:

- The thyroid gland enlarges  $\rightarrow$   $\uparrow$  vascularity + follicular hyperplasia.
- 50% increase in total  $T_3$  and  $T_4$  concentrations (due to oestrogen induced increase in thyroid binding globulin).
- Concentration of free  $T_3$  and  $T_4$  unchanged.
- TSH  $\downarrow$  in the first trimester but comes to normal at term.

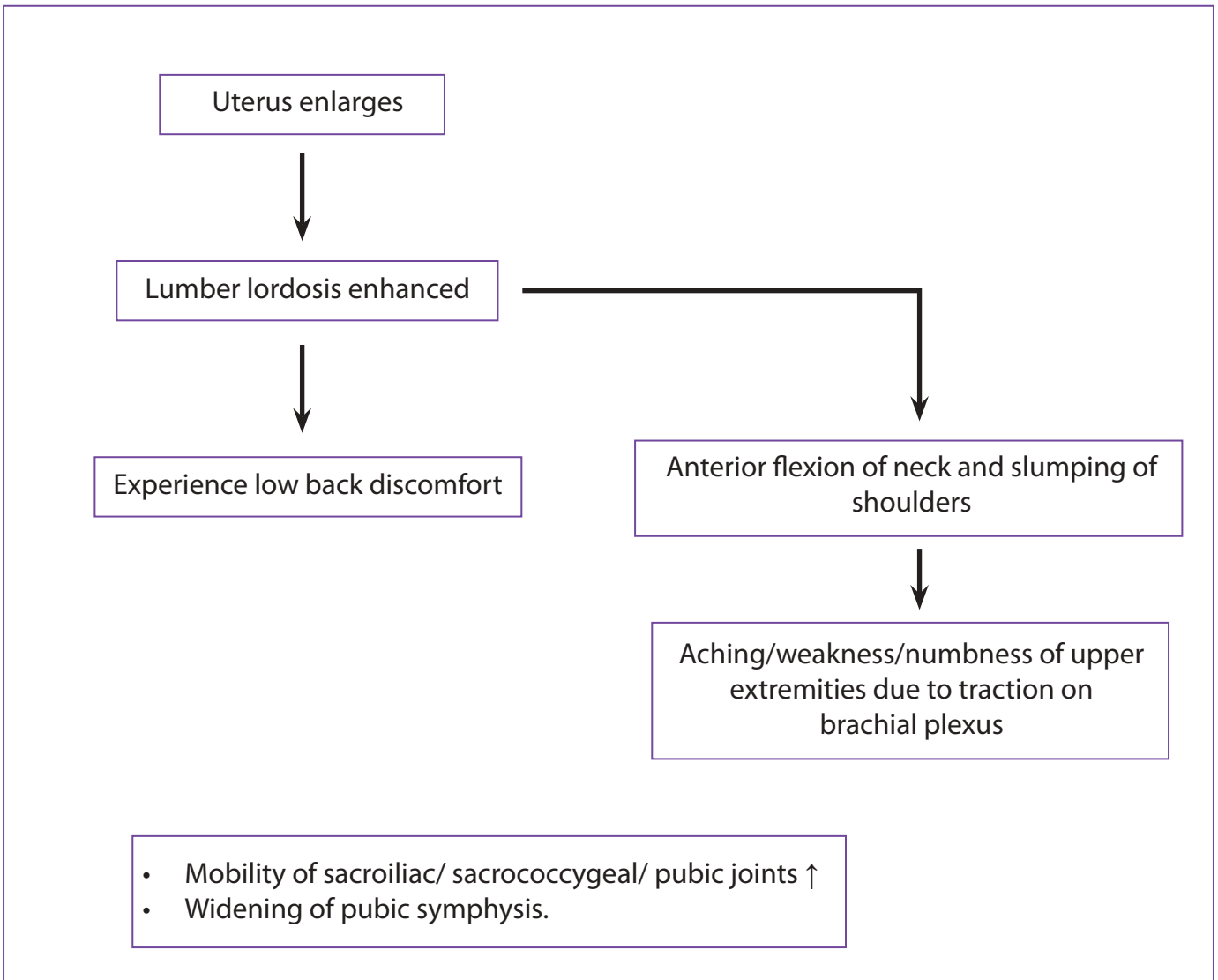
### ii. Adrenal Cortical function:



### iii. Pancreas and glucose metabolism:

- Pregnancy is a diabetogenic state, as the placenta secretes placental lactogen leading to reduced tissue sensitivity to insulin.
- Altered fasting blood glucose due to high glucose use of the feto-placental unit.
- Pregnant women exhibit an EXAGGERATED STARVATION KETOSIS.

### \* MUSCULOSKELETAL SYSTEM:



## \* IMMUNE SYSTEM:

- The blood leucocyte count rises from 6000/mm<sup>3</sup> to approximately 9000 - 11000/mm<sup>3</sup>.
- Serum concentration of immunoglobulin A, G and M UNCHANGED although humoral antibody titres to certain viruses DECREASED.
- Polymorphonuclear leukocyte function IMPAIRED during pregnancy.



Depressed neutrophil chemotaxis and adherence.



Increased incidence of infections with improvement of symptoms in pregnant women with autoimmune disease.

## \* ANAESTHETIC IMPLICATIONS:

### • Positioning the pregnant patient:W

- Accompanied by placing a cushion or wedge under the parturient's right hip or placing her in the lateral decubitus position.

### • Blood replacement:

- At delivery, maternal vascular capacitance is reduced by the volume of the intervillous space, i.e. at least 500 ml.
- Haemoconcentration occurs as maternal blood volume declines from 85 ml/kg to 65 – 70 ml/kg. These facts should be considered when making a decision as to whether a parturient should receive crystalloid, colloid or blood for volume replacement.

## i. General anaesthesia:

### i. Anaesthetic implications of maternal physiologic changes

- Endotracheal intubation:
  - Smaller endotracheal tubes required. (6.5 or 7.0 mm).
  - Increased risk of trauma with nasotracheal intubation.
  - Increased chance of difficult and failed intubation.
- Maternal oxygenation:
  - Increased physiologic shunt when supine.
  - Increased rate of deoxygenation.
  - Increased rate of decline of PaO<sub>2</sub> during apnoea.

- Maternal ventilation:
- Increased minute ventilation required.

## ii. General Anaesthesia: Change in pharmacology during pregnancy

- **Inhalation anaesthetics:**
  - Minimum alveolar concentration reduced by 20 – 40%.
  - Rate of induction increased.
- **Induction agents:**
  - ED<sub>50</sub> of thiopental reduced by 35% but the volume of distribution is increased.
  - The elimination half-life of thiopental is prolonged.
  - Propofol- Induction dose decreased
  - The elimination half-life of propofol unaltered.
- **Meperidine:**
  - Elimination half-life unaltered.
- **Succinylcholine:**
  - Duration of blockade unaltered (or decreased).
  - Sensitivity reduced.
  - Pseudocholinesterase activity is decreased.
- **Nondepolarising muscle relaxant:**
  - ED<sub>50</sub> of vecuronium reduced.
  - The elimination half-life of vecuronium and pancuronium shortened.
  - Rocuronium- increased sensitivity
  - Duration of the blockade of atracurium unaltered.
- **Chronotropic agents:**
  - Response diminished.
- **Vasopressors:**
  - Response variable.

## ii. Regional anaesthesia:

### i. Regional Anaesthesia: Anaesthetic implications of maternal physiologic changes

- Technical consideration:
  - Lumbar lordosis increased.
  - Head-down tilt when in lateral position.
  - CSF return unaltered.
  - Reduced sensitivity of “hanging drop technique.
- Hydration:
  - Increased fluid requirements to prevent hypotension.
- Local anaesthetic dose requirements:



- Subarachnoid dose reduced by 20 – 33%.
- Epidural dose unaltered or slightly reduced.
- Relative to that required by nonpregnant women.

Pregnant patients are particularly prone to hypotension and hemodynamic instability from the sympathetic block induced by neuraxial anaesthesia

### KEY POINTS TO REMEMBER:

- Oxygen consumption is increased by 30-40% in pregnancy; hence the pregnant patient is susceptible to rapid desaturation.
- Pregnant women are at increased risk for difficult or failed tracheal intubation.
- Due to aortocaval compression by the gravid uterus, it is advisable to have 15 degrees left lateral tilt in term pregnant patient. Placing a wedge under the right hip is an easy way.
- Due to caval compression, there is engorgement of epidural veins, increasing the chances of intravascular injection while attempting an epidural injection and reduces the local anaesthesia dose required to attain the same level of block.
- Gastric emptying is delayed in pregnancy. Hence the chances of acid aspiration are more. Adequate precaution should be taken before and during induction.
- Pregnant women have a greater sympathetic tone than nonpregnant women.

### CHECK YOUR PROGRESS:

- All of the following Cardio-vascular parameters change during pregnancy except:
  - Cardiac Output.
  - Blood Volume.
  - Central Venous Pressure.
  - Systemic Vascular Resistance.
- All are true about supine hypotension syndrome except:
  - Hypotension associated with pallor.
  - Relieved by putting a wedge under parturient's left hip.
  - Trendelenburg position may exacerbate the condition.
  - Occurs during the latter half of the pregnancy.
- All of the following drugs cross the placenta except:
  - Thiopental.
  - Glycopyrrolate.
  - Diazepam.
  - Morphine.
- All of the following are the complications of the oxytocin except:
  - Fetal distress.

- b. Uterine activity.
  - c. Transient systemic hypertension.
  - d. Maternal water intoxication.
- v. All of the following are true regarding the changes in the respiratory physiology during pregnancy except:
- a. ↑ Oxygen consumption.
  - b. ↑ Tidal volume.
  - c. Decreased PaCO<sub>2</sub>.
  - d. ↑ Functional residual capacity.
- vi. Following factors contribute to a decrease in the uterine blood flow during pregnancy except:
- a. Systemic hypotension.
  - b. Uterine vasoconstriction
  - c. Uterine contraction.
  - d. Alpha-adrenergic antagonists.
- vii. Drug of choice for hypotension during pregnancy is:
- a. Ephedrine.
  - b. Mephenteramine.
  - c. Methoxamine.
  - d. Metaraminol.
- viii. Absolute contraindication to regional anaesthesia include all except:
- a. Infection at the injection site.
  - b. Coagulopathy.
  - c. Pre-existing neurological disease.
  - d. True allergy to local anaesthetics.
- ix. Decreased segmental dose requirement of local anaesthetics can be due to all of the following except:
- a. Reduction of spinal CSF volume.
  - b. Enhanced neural susceptibility to local anaesthetics.
  - c. Injections made with the patients in the lateral position.
  - d. Injections made with the patients in the sitting position.
- x. Following haematological changes occur during pregnancy except:
- a. Factor II (Prothrombin) increases.
  - b. Hypercoagulable state.

- c. Dilutional anemia.
  - d. Nutritional anemia.
- xi. Which of the following agents may be administered to suppress uterine activity in pre-term labour:
- a. MgSO<sub>4</sub>.
  - b. Ethanol.
  - c. Beta-sympathomimetics.
  - d. Glucocorticoids.
- xii. Haemodynamic measurements taken in pre-eclamptic patients prior to therapeutic intervention likely would reveal:
- a. A high systemic vascular resistance.
  - b. A decrease in Cardiac index.
  - c. An increase in heart rate.
  - d. An increased intravascular volume.

**State true or false:**

- xiii. Cell-mediated immunity is markedly depressed in pregnancy.
- xiii. Increase in serum pseudocholinesterase activity occurs in pregnancy.
- xiii. 'Pyrosis' is an uncommon feature in a pregnant woman.
- xiii. Intra-gastric pressure is unchanged during pregnancy.
- xiii. Serum Alkaline Phosphatase is secreted by the placenta.
- xiii. Minimal alveolar concentration increases during pregnancy.
- xiii. Naso-tracheal intubations should be avoided in pregnant women.
- xiii. Physiological dead space decreases towards term in pregnancy.

**Answers**

- i. c
- ii. b
- iii. b
- iv. c
- v. d
- vi. d
- vii. a
- viii. c

- ix. d
- x. a
- xi. a
- xii. a
- xiii. T
- xiv. F
- xv. F
- xvi. F
- xvii. T
- xviii. F
- xix. T
- xx. T

**Further Readings:**

- Obstetric Anesthesia – Chestnut.
- Clinical Anesthesia – Bara.

# 07

## Pre-Anesthesia Checkup

---

### INTRODUCTION:

In an obstetric emergency, the anaesthesia caregiver can be called for:

- An emergency caesarean section (LSCS):
  - Foetal distress.
  - Obstetric haemorrhage.
- Removal of retained products of the placenta.
- Management of:
  - Uterine rupture.
  - Postpartum haemorrhage.

In such cases, the Anaesthesiologist has to respond promptly and take hold of the situation. Every woman admitted to the labour and delivery unit is a potential candidate for emergency administration of anaesthesia. Therefore, evaluate every patient after admission.

This module will help the Anaesthesiologist to assess the patients, their preparation & premedication and in preparing the operation theatre for them.

### OBJECTIVES:

After going through this module, the Anaesthesiologist should be able to:

- Describe how to prepare the patient, take relevant history and perform preoperative assessment & examination.
- Describe patient and theatre preparation.

### SKILLS:

- Preoperative Anaesthesia assessment
- Anaesthesia Machine check
- Communication skills

### \* PATIENT PREPARATION:

- Administer a clear antacid (30 ml of 0.3 M sodium citrate) about 30 minutes before surgery. Since sodium citrate is not readily available; administer Ranitidine 50 mg IV slowly or 150mg oral if time available, i.e., 30 minutes before the scheduled time of operation and Metoclopramide 10 mg oral if time available or IV as soon as surgery is decided.

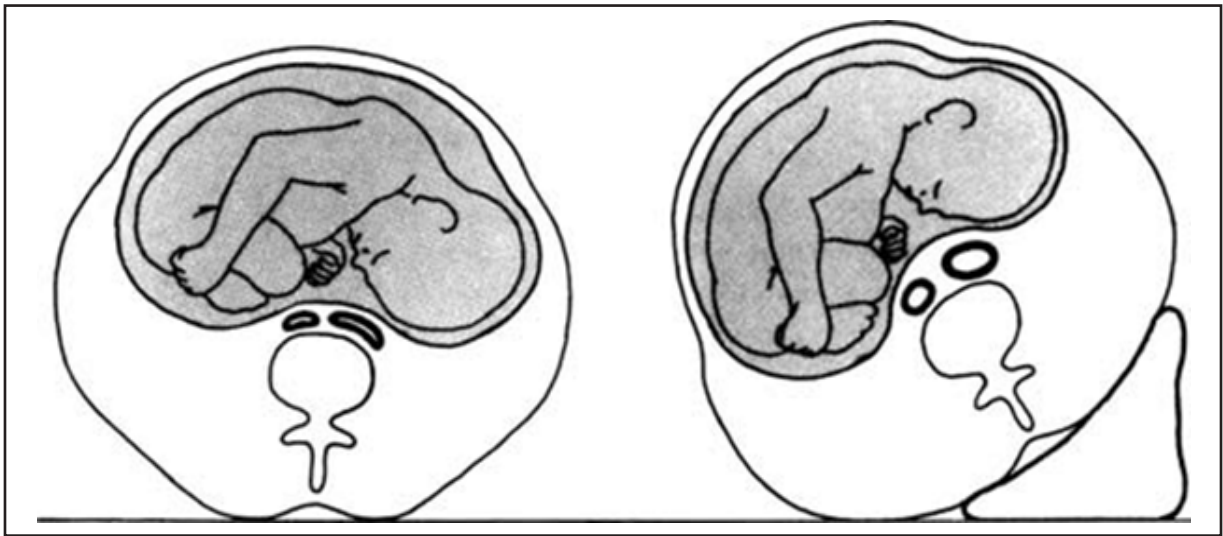
- Optimise maternal position.

A left uterine displacement has to be maintained to avoid aortocaval compression.

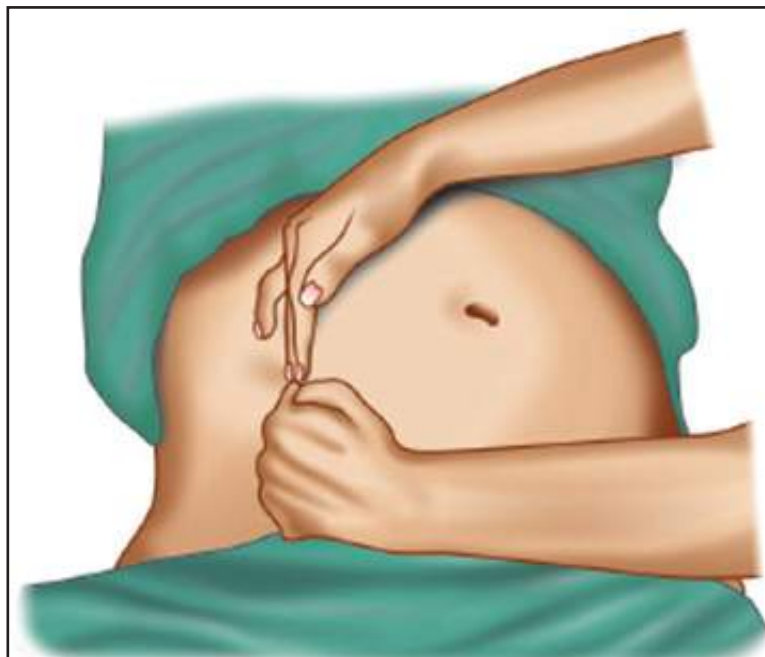
This is done by placing a wedge below the right buttock, at least at an angle of 15° (to 45°).

### Left uterine displacement

- Ensures adequate venous return by displacing the uterus from the inferior vena cava.
- Minimizes compression of aorta.
- Prevents decrease in uterine artery perfusion.



Alternatively, manual uterine displacement can be used



Also, change position to relieve umbilical cord compression.

- Administer oxygen by facemask at 4-5 liters/minute.

- Maintain maternal circulation.
  - A good IV line has to be established using 18 or 20 Gauge cannula.
  - Start resuscitation with IV fluid crystalloid/colloid (non-dextrose solution should be used).
  - Maternal hypotension should be promptly treated with ephedrine, which is an alpha and beta-agonist with a mixed action. Dose – 2.5-10 mg IV. The dose may be repeated if needed. IV Mephentermine could also be used in incremental doses of 3 mg.
  - If there is no improvement, use Injection phenylephrine 0.3-1 µg/kg boluses.

## \* QUICK ASSESSMENT OF PATIENT

### i. Focused history

- History of any significant illness
  - Diabetes.
  - Hypertensive disorder.
  - Asthma.
  - Allergy or anaphylaxis.
  - Heart disease.
  - Neurological illness.
  - Anaemia/ Sickle cell disease.
  - Any other past significant illness.
  - Obstetric history.
  - History of previous surgery and anaesthesia.
  - Any adverse events in pregnancy should be noted.

### ii. History of previous operation and anaesthesia

- Any problem faced during airway management or neuraxial block during previous surgeries
- The outcome of anaesthesia.

### iii. History of any complication during previous anaesthesia exposure

- Malignant hyperthermia.
- Nausea, vomiting.
- Delayed recovery.
- Postpartum Haemorrhage.

### iv. History of oral intake

- Liquid.
- Solid.
- The time of last oral intake.

## \* EXAMINATION

### i. General physical examination

- Hydration.
- Anaemia.
- Nutritional status.
- Pulse rate.
- Blood pressure.
- Jugular venous pressure (JVP).
- Oedema.

### ii. Airway assessment

- Profile examination of head, neck and face (Patient with a short neck, receding chin causes difficulty in intubation).
- Mouth opening (Mouth opening less than three finger breadths causes difficulty in oral intubation).
- Neck movements- look for any restriction in flexion or extension.
- Thyromental distance/compliance of the floor of the mouth.
- An enlarged breast can also make laryngoscopy difficult.

### iii. Modified Mallampati score

Ask the patient to open mouth as wide as possible and protrude the tongue to the maximum without vocalising oral cavity is visualised.

Class I - Able to visualise tonsillar pillars, uvula, soft palate.

Class II- Uvula and soft palate.

Class III- Soft palate

Class IV- Only hard palate

[Class IV is almost always associated with difficult intubation]

### iv. Teeth

- Loose teeth.
- Caps/crown.
- Denture.
- Protruding maxillary teeth.

### v. Back Examination

- Skin for infection, oedema, or deformity of the spine.

### vi. Systemic Examination

- Cardiovascular system: Auscultation of heart sounds-Any murmur (All diastolic murmurs are organic, palpable thrill is indicative of organic disease).



- Respiratory system: Auscultation of breath sounds. Any added sounds like crepitation and rhonchi.
- Abdominal examination: Any hepatosplenomegaly (Spleno-megaly is found in thalassemia).

### \* **PSYCHOLOGICAL PREPARATION**

- Reassure the patient.
- Tell the patient you are here for her.
- Tell her you will look after her during the whole procedure.
- Do not forget to tell a lady suffering from labour pain that you will relieve her pain. By this psychological assurance patient usually calms down.

### \* **ADMINISTRATIVE CONSIDERATIONS**

- Ask the name of the patient.
- Check the consent form- whether it is signed or not. A duly informed written consent to be taken.
- Confirm she is the same patient to be operated.

### \* **THEATRE PREPARATION**

#### i. **Anaesthesia equipment checklist**

- Back up ventilation (Ambu bag and mask, T-piece Bag-Mask Assembly with oxygen flow).
- High-pressure system (Check whether cylinders available or not and full or empty).
- O<sub>2</sub> fail-safe mechanism (Oxygen alarms).
- Low- pressure system (Flowmeters).
- Breathing system/ soda-lime/ presence of alternate circuit like Bain's
- Vaporisers with inhalational agent in it

#### ii. **Resources for airway management**

- Two **functioning laryngoscopes** and assorted blades.
- Endotracheal (ET) tubes with the stylet.
- Tube exchanger/ Bougie.
- A suction source with tubing and catheter.
- Medication for hypnosis, relaxation and blood pressure support.

#### iii. **Resources for difficult airway management:**

- Rigid laryngoscope blade.
- ET tubes of different size.
- LMA/ I – GEL or any second-generation Supraglottic devices.
- Jet ventilation/cricothyrotomy unit with TTJV.
- Combitube.
- Semirigid stylet.

- Equipment for emergent surgical airway (e.g., - cricothyroidotomy/tracheostomy set etc).
- Topical anaesthesia and vasoconstrictor.
- Fibreoptic bronchoscope.

#### iv. Resources for Obstetric Haemorrhagic Emergency:

- Large-bore IV catheter.
- Fluid warmer.
- Forced air body warmer.
- Blood bank resource.
- Pressure bags and automated rapid infusion device.
- Tranexamic acid

### \* MONITORING EQUIPMENT

#### i. Maternal monitoring:

- ECG.
- Blood pressure (noninvasive).
- Pulse oximetry.
- Temperature.
- Capnography.

#### ii. Foetal Monitoring:

- Foetal heart rate.

### KEY POINTS TO REMEMBER

- A brief but thorough pre-anaesthesia check-up of the patient is essential even in emergency circumstances.
- Administration of non-particulate antacid (30 ml 0.3 m sodium citrate) 30 minutes before surgery raises the gastric pH.
- Once the patient is shifted to the operation theatre, administer oxygen by face mask to the mother.
- Always maintain left uterine displacement with the help of wedge.
- Start a large-bore intravenous line (18 G) before the commencement of any procedure.
- A functioning suction and airway equipment should always be at hand.

### CHECK YOUR PROGRESS

- Indicate whether true or false (T/F)
  - Sodium citrate is available as a 0.6 molar solution. (T/F)
  - Mouth opening less than 4 cm is associated with difficulty in intubation. (T/F)

ii. Fill in the blanks

- a. A non-particulate antacid e.g. sodium citrate should be given \_\_\_\_\_ minutes before surgery.
- b. A left uterine displacement is provided to avoid \_\_\_\_\_ compression.
- c. In modified Mallampati class IV, only \_\_\_\_\_ is visible.

iii. What structure(s) is/ are visible of the following represent modified Mallampati class III.

- a. Hard palate & soft palate.
- b. Hard palate only.
- c. Hard palate, soft palate & uvula.
- d. Hard palate & fauces.

**Answers**

- i. (a) False.
  - i. (b) True.
  - ii. (a) 30-45 minutes.
  - ii. (b) Aortocaval.
  - ii. (c) Hard palate.
  - iii. a
-

# Week 3 - Module

## Airway Management



# 08, 09, & 10

## Airway management I, Airway Gadgets II & Airway gadgets III

---

### \* PREOPERATIVE ASSESSMENT OF AIRWAY

Preoperative assessment of airway is compulsory for all patients coming for anaesthesia. This helps to formulate and prepare a plan of action. A difficulty, which has not been anticipated and evaluated, can lead to a delay in placing the ETT and may also be fatal. Airway assessment – can be done globally, regionally and radiologically.

#### i. Global:

General examination of the body, head and neck to look for the following (as all these factors may interfere with ventilation/intubation or both):

- Facial profile.
- Symmetry.
- Proportions of face and neck.
- Presence of beard.
- Double chin.
- Flat bridge of the nose.
- Oedema.
- Swelling or scarring.

#### ii. Regional examination

The examination of the airway includes an examination of the oral cavity, relative tongue/pharyngeal size, atlanto-occipital joint extension and mandibular space. Some details of these are given below.

#### Oral cavity

Look for

- Mouth opening-Adequacy (an inter incisor gap of at least 4 cm).
- Lip and palate- Growth/deformity.
- Teeth- Number, loose or missing teeth.

## Relative tongue size with respect to pharynx:

Mallampati and subsequently Samsoon and Young described a test, which assesses the size of the tongue and its effect on laryngoscopy. If the base of the tongue is disproportionately large, viewing of the larynx with direct laryngoscopy is likely to be difficult.

Similarly, a large tongue may obscure viewing of the faucial pillars uvula and soft palate. With the patient sitting upright, head in the neutral position, mouth fully opened and tongue maximally protruded, the observer sitting opposite the patient with eyes at the level of the pharynx to assess the pharyngeal structures. Laryngoscopy is likely to be difficult when the base of the tongue obscures viewing of the facial pillars; uvula and soft palate.

Depending on the structures visualised, the patient may be assigned to one of the following classes. Samsoon and Young's modification of Mallampati classification

- Class I: Soft palate, uvula, tonsillar pillars seen
- Class II: Soft palate and fauces seen
- Class III: Soft palate seen
- Class IV: Hard palate only seen
- Class I & II: Intubation likely to be easier.
- Class III & IV: Intubation likely to be more difficult.

## Atlanto-occipital joint extension:

Extension of the head with the neck flexed brings the axis of the mouth into alignment with the axes of the larynx and pharynx. Measure the range of head and neck movement – by asking the patient to extend the head and neck and keeping a pencil on the forehead with its orientation parallel to a window frame and then sighting it against the horizontal of the window frame to see if it has moved through 90 degrees. When the movement at this joint is less than 30 degrees, difficulty in intubation is to be anticipated.

## Mandibular space:

The Thyromental distance reflects the mandibular space, which is the space into which the tongue gets displaced during laryngoscopy in order to align the oral, pharyngeal and laryngeal axes.

- Is the distance from the thyroid notch to the mental prominence when the neck is extended fully
- The normal distance is 6.5cm or greater.
- 6.0-6.5 cm- without other anatomical problems laryngoscopy and intubation are difficult but usually possible.
- Less than 6.0 cm-Laryngoscopy may be impossible.

## A rapid assessment of the airway by the rule of 1-2-3:

Three factors determine the ease of visualisation of the glottis.

- Movement of temporomandibular joint.
- The extent of Mouth opening.
- Size of Mandibular space

This consists of 3 basic steps:

- **Step 1:** Ability to insinuate one finger in from the tragus while the patient opens his mouth (establishes movement at the temporomandibular joint).
- **Step 2:** Determining the adequacy of mouth opening by quantifying the inter incisor gap, which would be at least two fingerbreadths.
- **Step3:** Measurement of thyromental distance, which should be at least 3 fingerbreadths.

### Radiological Assessment:

- Posterior depth of the mandible.
- The gap between the occiput and C1 vertebra.

These days ultrasound-based parameters like tongue volume, skin to vocal cord distance and mandibular condylar mobility etc., are also being used.

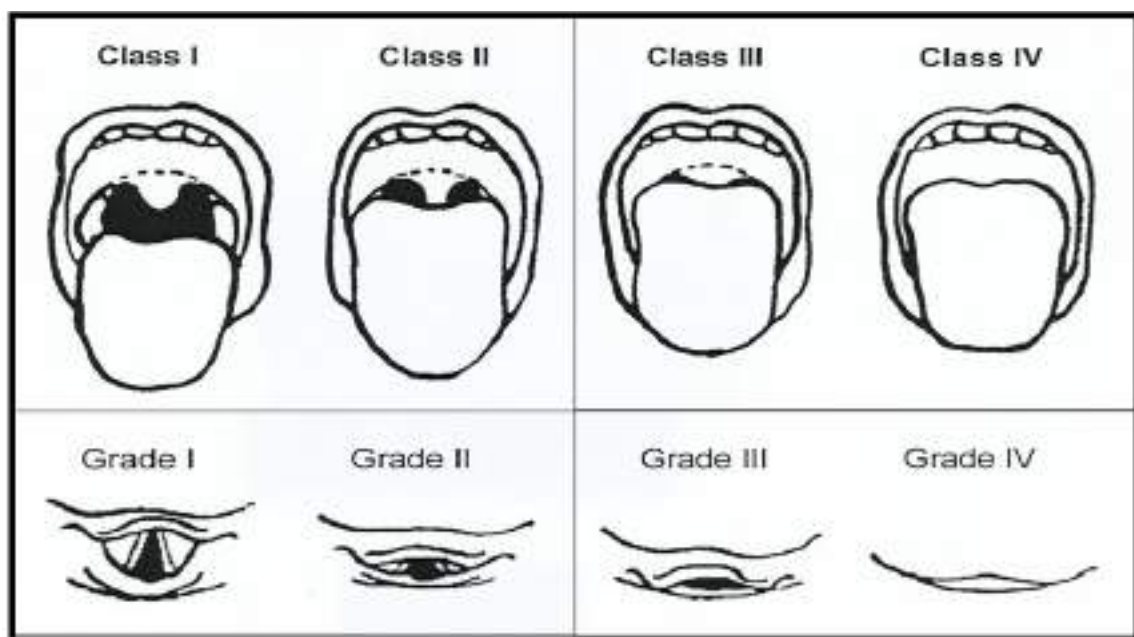
**Note:** No one factor can predict difficulty in intubation accurately as the adverse effect of one factor may be offset by favourable features, among others. When more than one adverse factors are identified, it is important to plan for difficult intubation.

### \* Grade of glottic exposure:

Described by Cormack and Lehane.

- **Grade-1** Glottis (including the anterior and posterior commissures) could be fully exposed.
- **Grade-2** Glottis could be partly exposed (anterior commissure could not be visualised).
- **Grade-3** Glottis could not be exposed (corniculate cartilages only could be visualised).
- **Grade-4** Glottis, including corniculate cartilages, could not be visualised.

### Mallampati Classification & Cormack Lehane Grade





\* **Airway assessment-deductions derived:**

- Whether the airway can be maintained with a mask.
- Whether mask ventilation is sufficient or intubation would be needed.
- If intubation is needed, can it be performed safely with the patient anaesthetised or awake intubation would be necessary?
- Whether the patient can be safely paralysed or spontaneous respiration needs to be maintained
- If nasal intubation is needed, if whether a direct view is possible or must it be blind.

**LEMON Airway Assessment Method:**

**L:** Look externally (Facial trauma, Large incisors, Beard or Moustache, Large tongue).

**E:** Evaluate the 3-3-2 rule (Incisor distance -3 fingers' breadth (FB), Hyoid-mental distance -3FB, Thyroid to mouth distance -2FB).

**M:** Mallampati classification (Score > 3).

**O:** Obstruction (Presence of any condition like Epiglottitis, Peritonsillar abscess, trauma).

**N:** Neck mobility (Limited neck mobility).

No one factor can predict difficulty in intubation accurately as the adverse effect of one factor may be offset by favourable features, among others. When more than one adverse factors are identified, it is important to plan for difficult intubation.



# 11

## Assessment and Management of Airway Including Difficult Airway

---

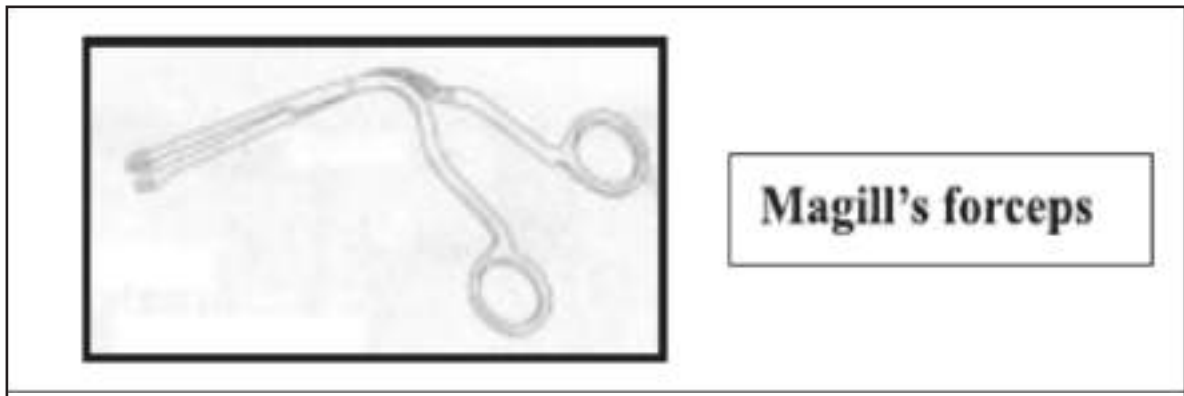
### DEFINITIONS:

- The difficult airway is a clinical situation in which a conventionally trained Anaesthesiologist experiences difficulty with face mask ventilation of the upper airway, difficulty with tracheal intubation or both.
- Difficult Laryngoscopy: It is not possible to visualise any portion of the vocal cords after multiple attempts at conventional laryngoscopy.
- Difficult tracheal intubation is defined Tracheal intubation requires multiple attempts in the presence or absence of tracheal pathology.
- Difficult mask ventilation is defined in various ways, e.g. is Inability to maintain O<sub>2</sub> saturation > 90% using 100% O<sub>2</sub>.
- Or It is combined with Difficult facemask or Supraglottic airway ventilation: Where it is not possible for Anaesthesiologist to provide adequate ventilation because of one or more reasons.

### \* DIFFICULT AIRWAY CART- CONTENTS:

- Face masks –All sizes.
- Endotracheal tubes – all sizes with intact cuffs.
- Tongue depressor.
- Rigid mouldable stylets.
- At least two working laryngoscopes with all sizes of blades both curved and straight types.
- Airways of all sizes, both oropharyngeal and nasopharyngeal.
- Magill's forceps.
- Suction apparatus with suction catheters.
- Oxygen source.
- A ventilating apparatus with suitable adaptors to the mask and tube.
- A head rest or a pillow with a minimum height of 10 cms.
- LMA-All sizes.
- Flexible fiberoptic laryngoscope/Bronchoscope.
- Tracheostomy kit.
- Light wand.

- Equipment for retrograde intubation and needle cricothyrotomy.
- Combitube.

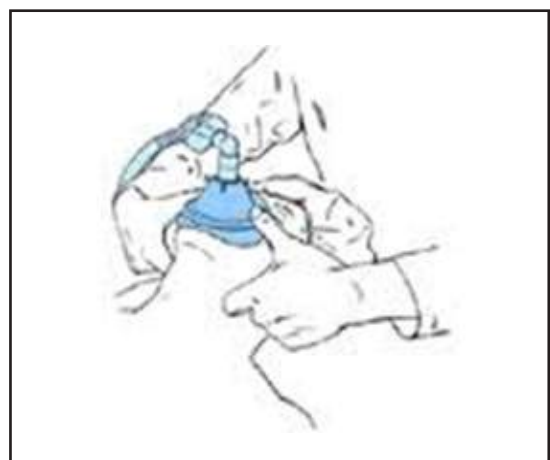


\* **CERTAIN USEFUL AIRWAY EQUIPMENT:**

**i. Face mask:**

Anaesthesia facemasks are made of either rubber or plastic and are employed to administer oxygen and anaesthetic gases and to ventilate the non-intubated patient.

- Three parts-
  - Body- if transparent allows observation for secretions, condensation of exhaled gases.
  - Seal (rim, flap)- 2 types, pad & flange.
  - Connector- 22 mm ID, hooks may or may not be present.
- *Mask is held by thumb and index finger and upward pull on the jaw by other three fingers to obtain an airtight seal.*
- *One hand or two hands- E-C clamp.*
- *Avoid pressures on eyes, soft tissues.*





Ventilation with mask requires a tight fit that involves:

- Downward displacement of the mask with the thumb and index finger.
- Upward displacement of the mandible with the other three fingers.
- Mandibular displacement along with upper cervical extension and chin lift all tend to pull the tongue and soft tissues up off the posterior pharyngeal wall and relieve the upper airway obstruction that occurs in the anaesthetised or unconscious patient.
- This may require holding the mask with two hands and vigorously pulling the mandible forwards.

## ii. Mechanical airways:

When airway integrity cannot be maintained with manipulation of mask, mandible or neck a mechanical airway may help restore airway patency. Both oral and nasal airways serve to separate the tongue from the posterior pharyngeal wall.

### Oral Airways:

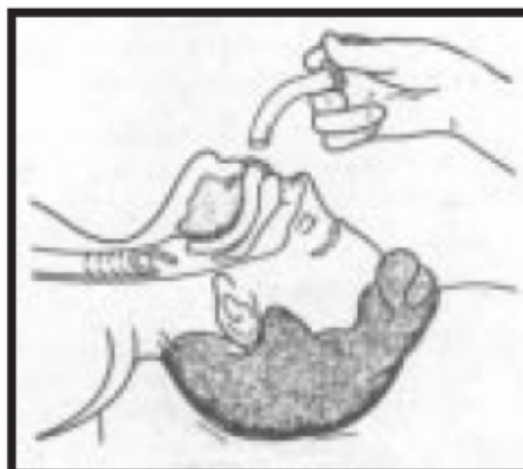
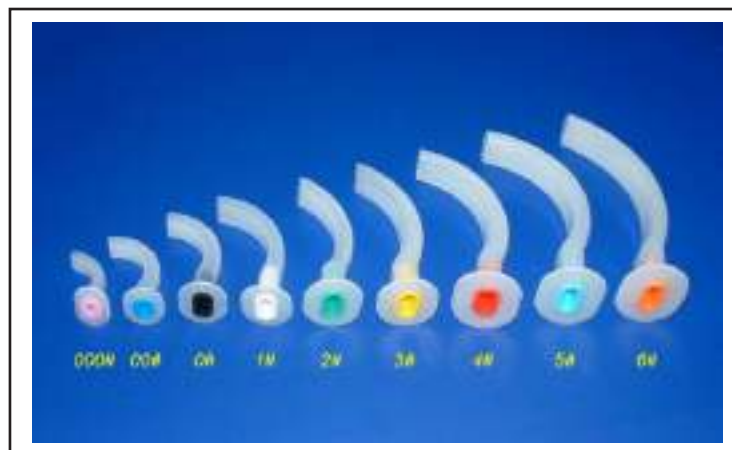
- Purpose- to lift the tongue & epiglottis away from the posterior pharyngeal wall & prevent them from obstructing the space above the larynx.
- All oral airways have a flange to prevent over-insertion, a straight bite block portion & a curve section leading to air channel.
- It is inserted upside down and then rotated 180 degrees into the position of function. Avoid trauma to the teeth as well as a misplacement in which the airway pushes the tongue back into the pharynx and actually increases airway obstruction. For this, the selection of an appropriately sized oral airway is vital. This can be done by selecting an airway whose length from flange to tip equals the distance between the angle of the mouth to the angle of the mandible. Too small-may cause the tongue to kink & force part of it against the roof of the mouth, causing the obstruction. Too large- obstruction by displacing the epiglottis posteriorly & may traumatise the larynx.



**Correct sizing**

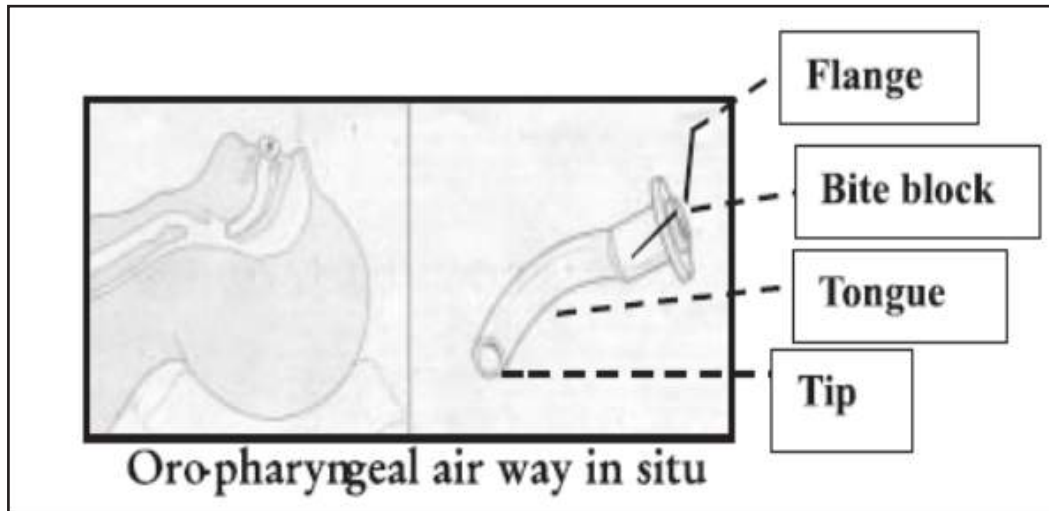
After intubation, an airway may be inserted to prevent the patient from biting down on the tube. It is generally made of plastic. Pharyngeal and laryngeal reflexes should be depressed before insertion.

**Different sizes**



### Insertion of Oro-pharyngeal Airway to maintain airway patency

- Sizes Adult – 80, 90 and 100 mm (nos. 3, 4 & 5 respectively).
- Children – 50, 60, 70 mm (nos. 0, 1 & 2).
- Special small airways (00,000) for premature and newborn babies.

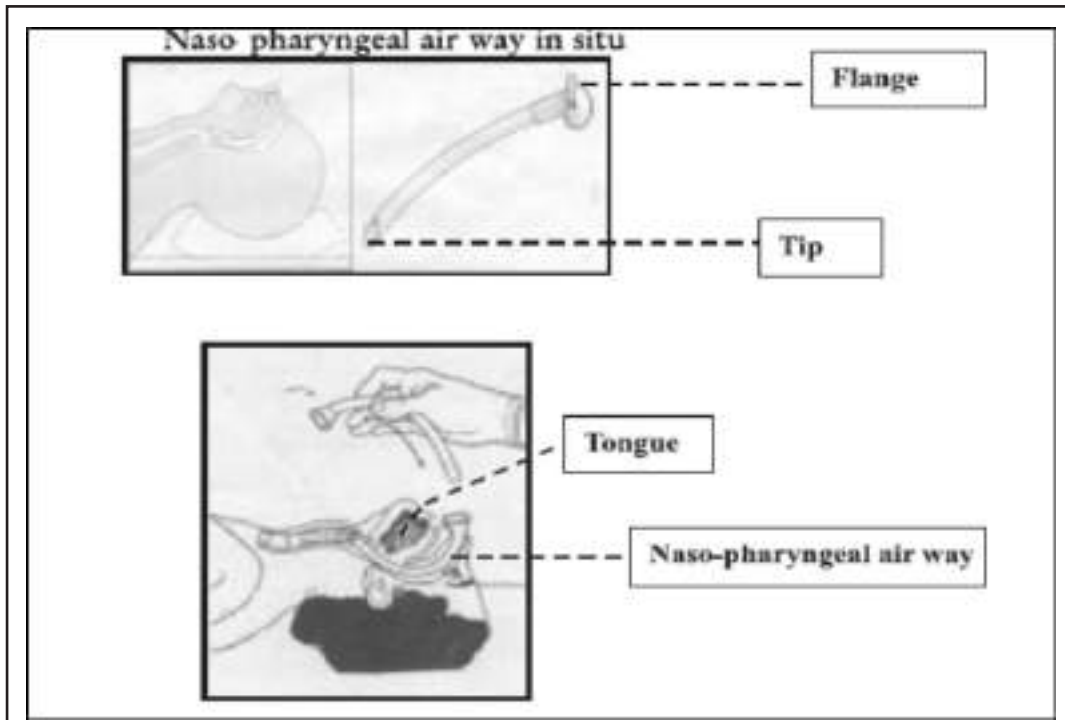


### Nasal Airway:

- Nasal airways are softer and are useful in patients who are not deeply anaesthetised since they tend to provoke less of a gag reflex.
- Vasoconstriction with phenylephrine nasal drops (and topical anaesthesia with lidocaine if the patient is awake) should precede insertion. However, in the acute situation, the lubricating quality of lidocaine ointment is sufficient. Tip of the Airway is inserted perpendicular to the face and not upwards towards the cribriform plate. Length of the Airway should correspond to the distance from the tip of the nose to meatus of the ear. It is better to avoid nasal airway insertion in the presence of coagulopathy, basilar skull fractures, nasal infections or deformities. Different types- Portex, Rusch, Linder, cuffed, bi-nasal.



Sizing



### Insertion of Nasopharyngeal Airway to maintain airway patency

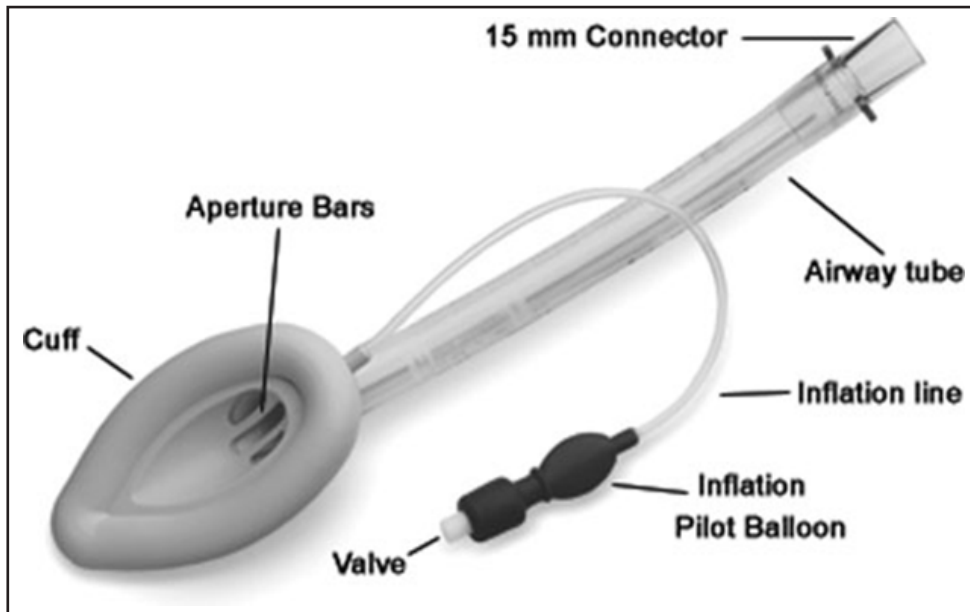
Contraindications of NPA insertion- Haemorrhagic disorders, anticoagulants or a coagulopathy, basilar skull fracture or pathology, sepsis, severe deformity of the nose or nasopharynx, history of epistaxis requiring medical treatment. It should be avoided in pregnant women because of increased vascularity.

### iii. The Laryngeal Mask Airway (LMA):

LMA allows administration of inhaled anaesthetics through a minimally stimulated airway. Its relative ease of insertion suggested its potential usefulness in fields of airway management of difficult or failed intubation.

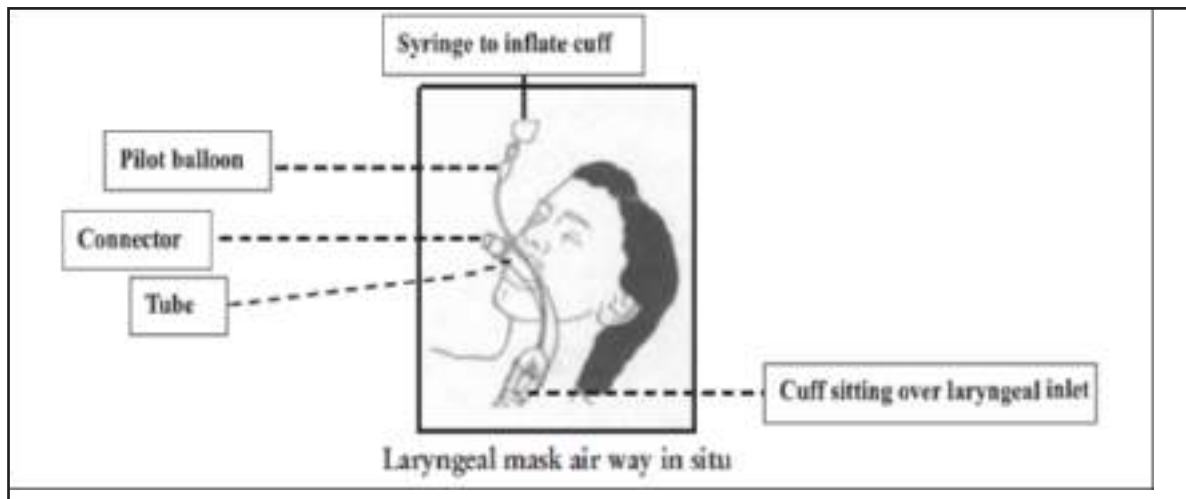
**Design** - It consists of a tube, cuff, and pilot tube.





LMA Sizes	Patient Weight (Kg)	Maximum Cuff Volume (ml)
1	Upto 5	4
1.5	5 - 10	7
2	10 - 20	10
2.5	20 - 30	15
3	Small Adult	20
4	Average Sized Adult	30
5	Large Sized Adult	40

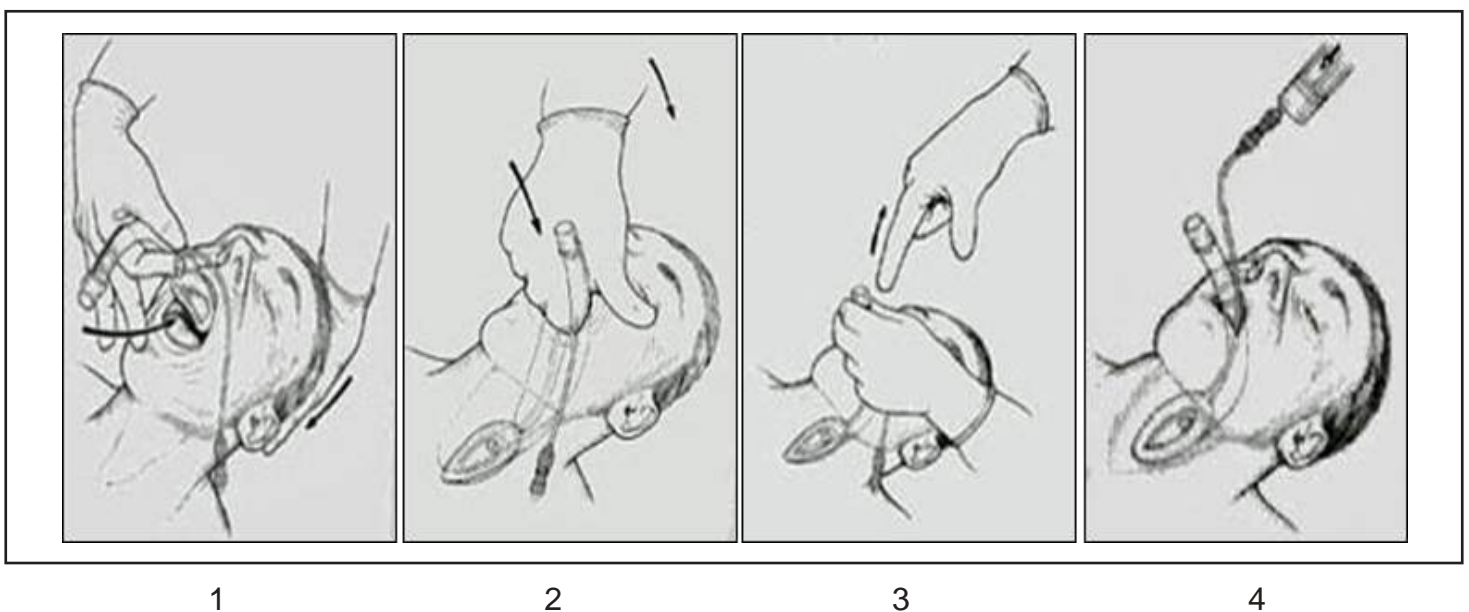




### Technique of insertion:

- Head position (recommended by Brain) for insertion is “SNIFFING THE MORNING AIR” (i.e. neck flexion and head extension).
- Lubrication - only the posterior aspect of cuff is lubricated (because any gel on the anterior aspect of the cuff may cause airway obstruction or laryngospasm at light levels of anaesthesia).
- The Index finger of the operator’s hand may be used to guide the LMA over the back of the tongue.
- The tip of the cuff is pressed posteriorly against the hard palate.
- The black longitudinal line on the shaft of the LMA should face the midline of the upper lip.
- IPPV is usually accompanied by an audible leak around the LMA.
- Removal - done when the patient is awake and obeying commands.
- Physiologic responses to insertion are of a lesser magnitude compared to that of tracheal tube insertion.

### LMA Insertion technique





#### Insertion steps:

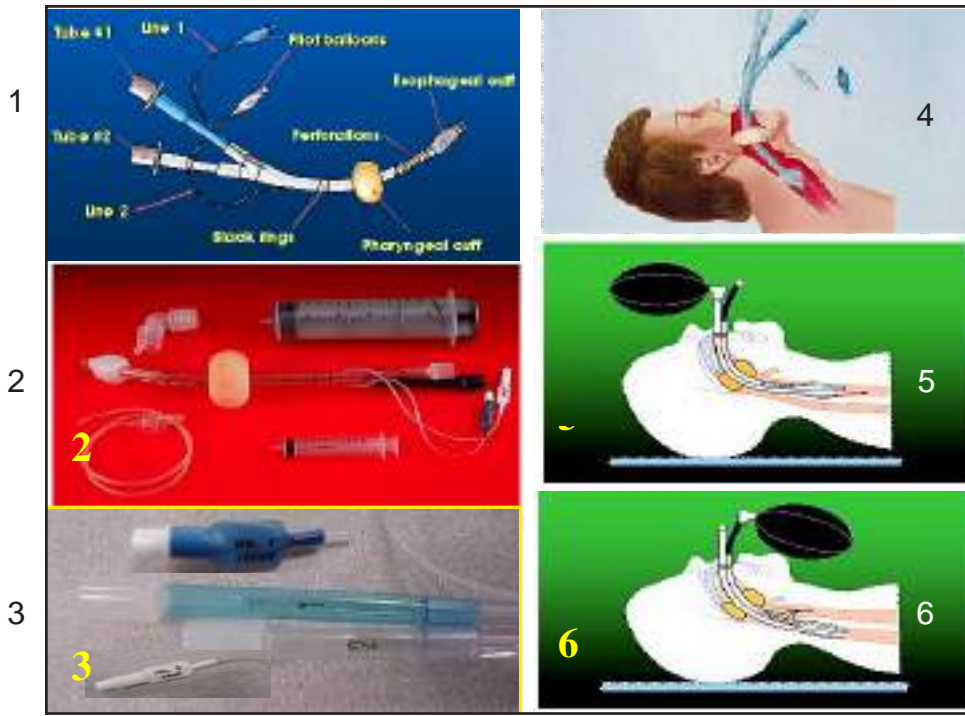
1. Press mask tip upwards against the hard palate to flatten it out and advance the mask into the pharynx using the index finger.
2. With neck flexed and head extended, press the laryngeal mask airway into the posterior pharyngeal wall using the index finger.
3. Complete the insertion by exerting cephalad pressure by the nondominant hand prior to removing the index finger.
4. Inflate laryngeal mask airway (see Table for details) and secure in place with tape. 6 for details) and secure in place with tape.

#### Indicators of correct positioning

- Inflation of cuff causes
- slight upward movement of the device
- bulging of the front of the neck
- Auscultation of normal breath sounds
- The black line faces the patient
- Expired CO<sub>2</sub> waveform
- Absence of stridor, tracheal tug or out of respiratory phase movement of chest & abdomen

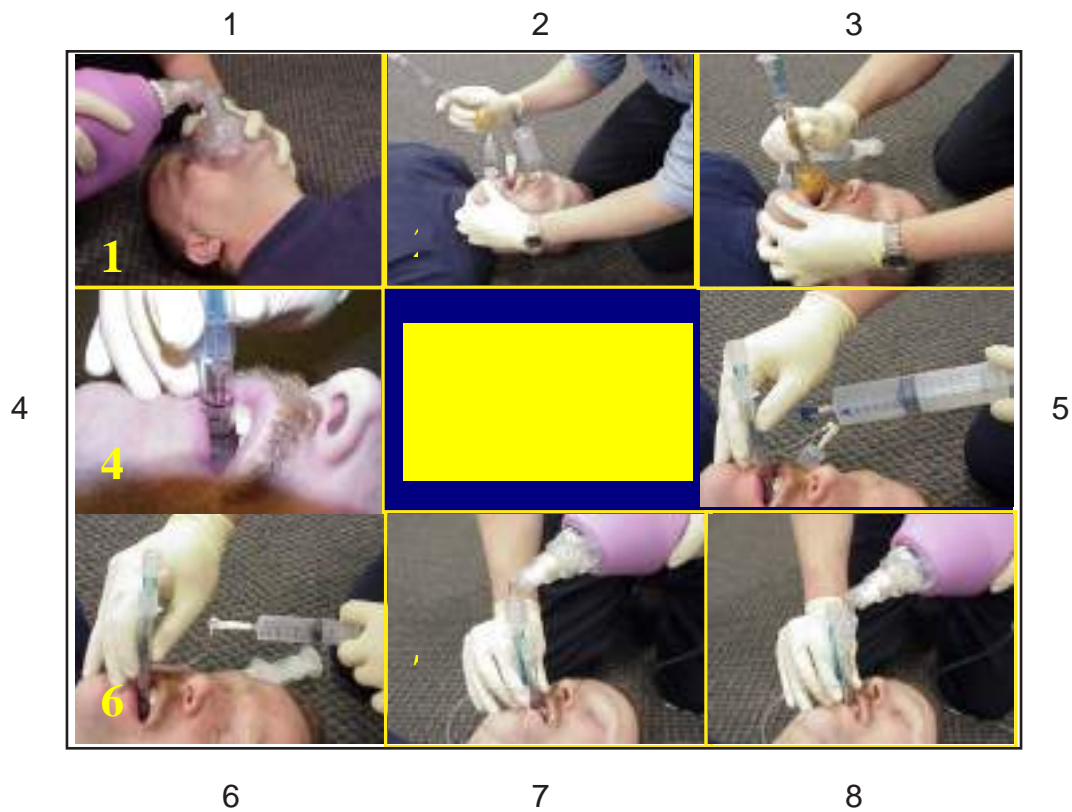
#### iv. The combitube (oesophago-tracheal combitube):

It is a double-lumen tube that is inserted blindly orally. The oesophageal lumen tube has a closed distal end; it has flexibility in that it may be used regardless of which orifice the tube enters, e.g. the trachea or the oesophagus. If the tube enters the oesophagus, which is the most likely pathway, following blind insertion, the oesophageal cuff is inflated to prevent regurgitation around the tube. The proximal cuff occupies the pharynx above the airway and prevents leakage externally through the mouth and nose. Perforations in the oesophageal lumen of the combitube allow ventilation of the lungs. If the oesophageal tracheal tube enters the trachea, ventilation may take place via the tracheal lumen. The combitube is an excellent alternative to endotracheal tube for cardiopulmonary resuscitation or failed endotracheal intubation, which could be used by paramedical staff in the ICU or at the site of the accident.



1. Components of a TE-Combitube.
2. TE-Combitube Intubating equipments.
3. Tube with corresponding pilot balloons.
4. Intubated patient.
5. Esophageal intubation.
6. Tracheal intubation.

### Combitube Insertion Technique



1. Place the patient in a supine position. Provide artificial ventilation via Bag Mask and hyperventilate the patient with 100% oxygen prior to device insertion
2. Position the patient's neck in a neutral position. Lubricate the tube with sterile, water soluble lubricant. Lift the tongue and lower jaw upward to open the oropharynx.
3. Insert the Combitube so that it curves in the same direction as the natural curvature of the pharynx. If resistance is met, withdraw tube and attempt to reinsert.
4. Advance tube until the patient's teeth are between the two black lines.
5. Inflate the #1 blue pilot cuff with 100 ml (41 Fr)/ 85 ml (37 Fr) of the air with large (41 Fr) syringe.
6. Inflate the #2 white pilot cuff with 15 ml (41 Fr)/ 12 ml (37 Fr) of the air with small (41 Fr) syringe.
7. Begin ventilation through the longer blue tube labeled #1. If auscultation of breath sounds is good and gastric inflation is negative, continue.
8. If auscultation of breath sounds is absent and gastric inflation is positive, then begin ventilation through the shorter clear tube labeled #2
9. Place the patient in a supine position. Provide artificial ventilation via BVM and hyperventilate the patient with 100% oxygen prior to device insertion
10. Position the patient's neck in a neutral position. Lubricate the tube with sterile, water soluble lubricant. Lift the tongue and lower jaw upward to open the oropharynx.
11. Insert the Combitube so that it curves in the same direction as the natural curvature of the pharynx. If resistance is met, withdraw tube and attempt to reinsert.
12. Advance tube until the patient's teeth are between the two black lines.
13. Inflate the #1 blue pilot cuff with 100 ml (41 Fr)/ 85 ml (37 Fr) of the air with large (41 Fr) syringe.
14. Inflate the #2 white pilot cuff with 15 ml (41 Fr)/ 12 ml (37 Fr) of the air with small (41 Fr) syringe.
15. Begin ventilation through the longer blue tube labeled #1. If auscultation of breath sounds is good and gastric inflation is negative, continue.
16. If auscultation of breath sounds is absent and gastric inflation is positive, then begin ventilation through the shorter clear tube labeled #2.

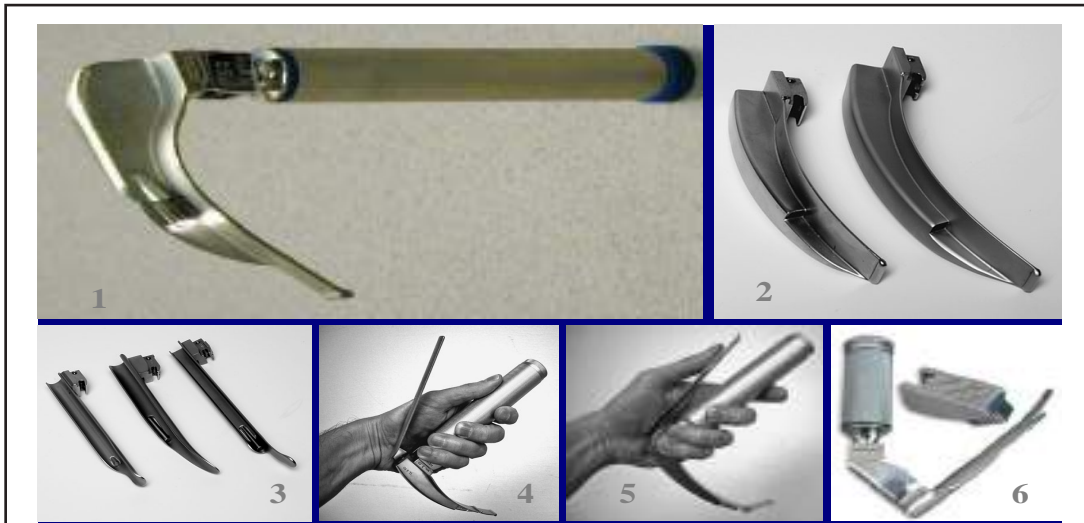
#### **v. Laryngoscopes:**

Standard rigid laryngoscope consists of a detachable blade with the removable bulb that connects to a battery-containing handle. Curved blade introduced by MacIntosh is probably most popular for adult use. A variant of the MacIntosh blade is the McCoy blade, which has a flexible tip controllable through a lever attached to the handle. The commonly used straight blade is the Miller blade.

Straight blade - only advantageous when the mouth opening is limited, or larynx is anterior.

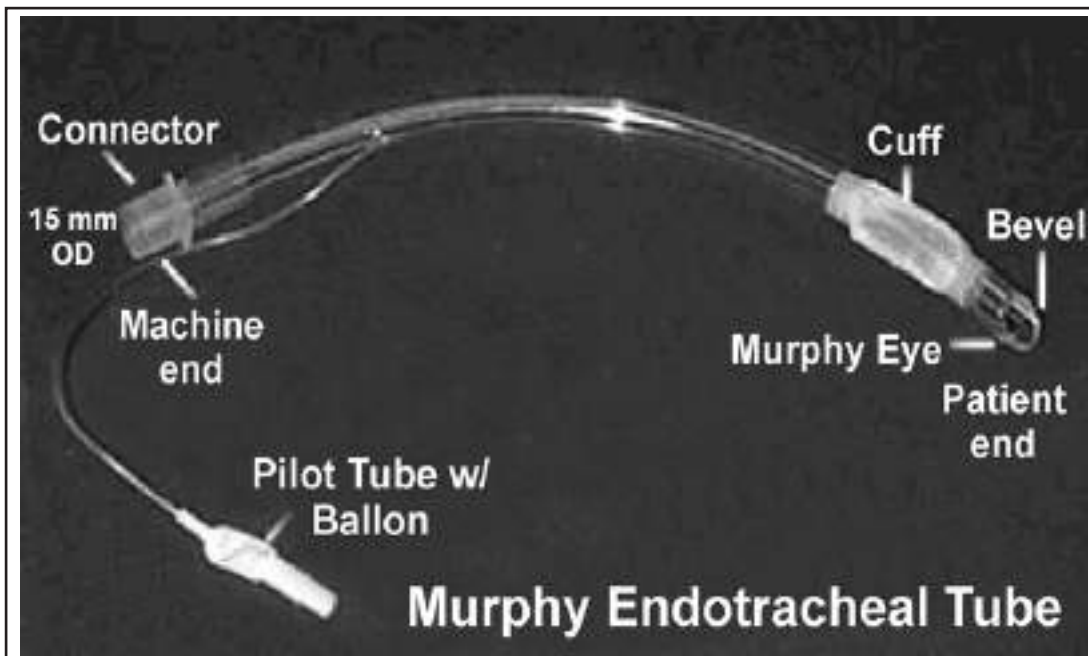
Curved blade - advantageous when more room is desired to perform instrumentation (e.g. use of Magill's forceps; changing tubes; intubation with oesophageal obturator in place).

## Laryngoscopes



1. Mac Intosh laryngoscope
2. Curve Blades
3. Straight Blades
4. McCoy (Normal)
5. McCoy (in Use)
6. Howland Lock laryngoscope with stubby handle

## Endotracheal tube part



## Introducers



### \* **NEEDLE CRICOTHYROTOMY (TTJV):**

In the event of inability to intubate the trachea or ventilate the lungs needle cricothyrotomy or tracheostomy are the final recourse.

### **Advantage of Cricothyrotomy over Tracheostomy:**

- Can be performed in lateral position.
- Easier to perform.
- Fewer instruments needed.
- Takes shorter time.
- 

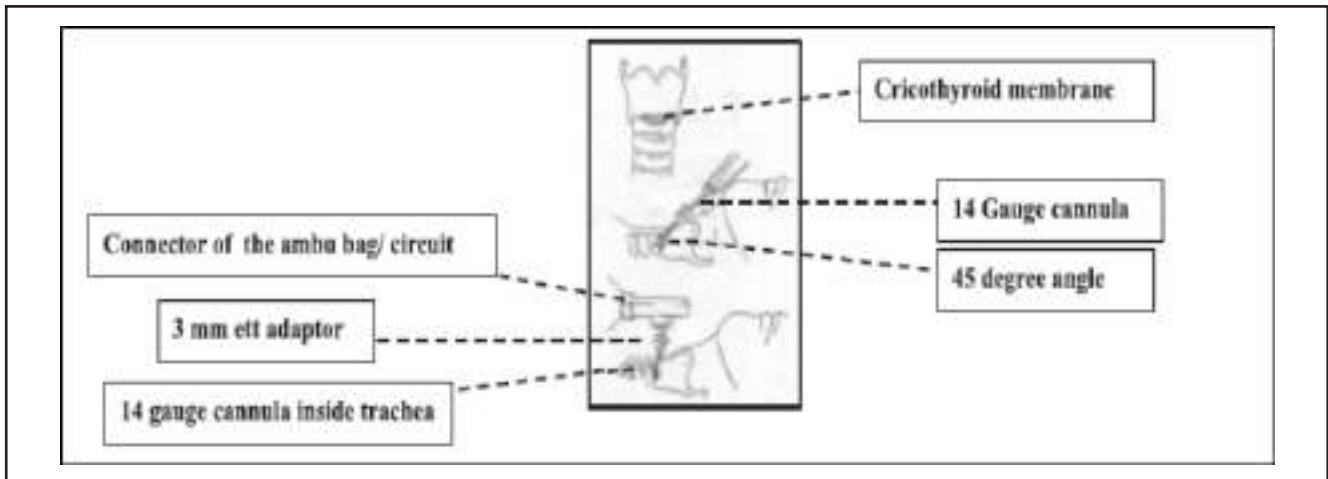
### **Procedure:**

It is performed by placing a 12-14 gauge needle or catheter through the cricothyroid membrane into the trachea. An alternative site - is the subcricoid region between the cricoid cartilage and first tracheal ring. The correct placement of the needle is confirmed by aspiration of air from the trachea.

A needle is preferred to a plastic intravenous cannula as the latter may kink and occlude. An artery forceps is clipped onto the needle where it penetrates the skin to hold it in position. Intermittent pressurised oxygen provides the most suitable method for ventilation through these small diameter needles, and the simplest method is to use the emergency O<sub>2</sub> flush button. The pressurised O<sub>2</sub> is delivered from the common gas outlet via a length of tubing with a Luer lock connector for attachment to the needle. A three-way tap interposed between the tubing & needle will provide the initial facility to aspirate air from the trachea, thus confirming correct placement. In order to avoid barotraumas, it is important to allow deflation of the lungs to occur between inflation.

This takes place passively through the mouth, and it is usually possible since most airway obstructions are inspiratory.





### \* **FAILED INTUBATION DRILL**

If intubation failed for two times by the same Anaesthesiologist,

Call for help,

Ventilate with 100% oxygen,

Use:

- Face mask.
- Laryngeal mask airway (LMA) with cricoid pressure.
- Combitube.

Assess ventilation and oxygenation.

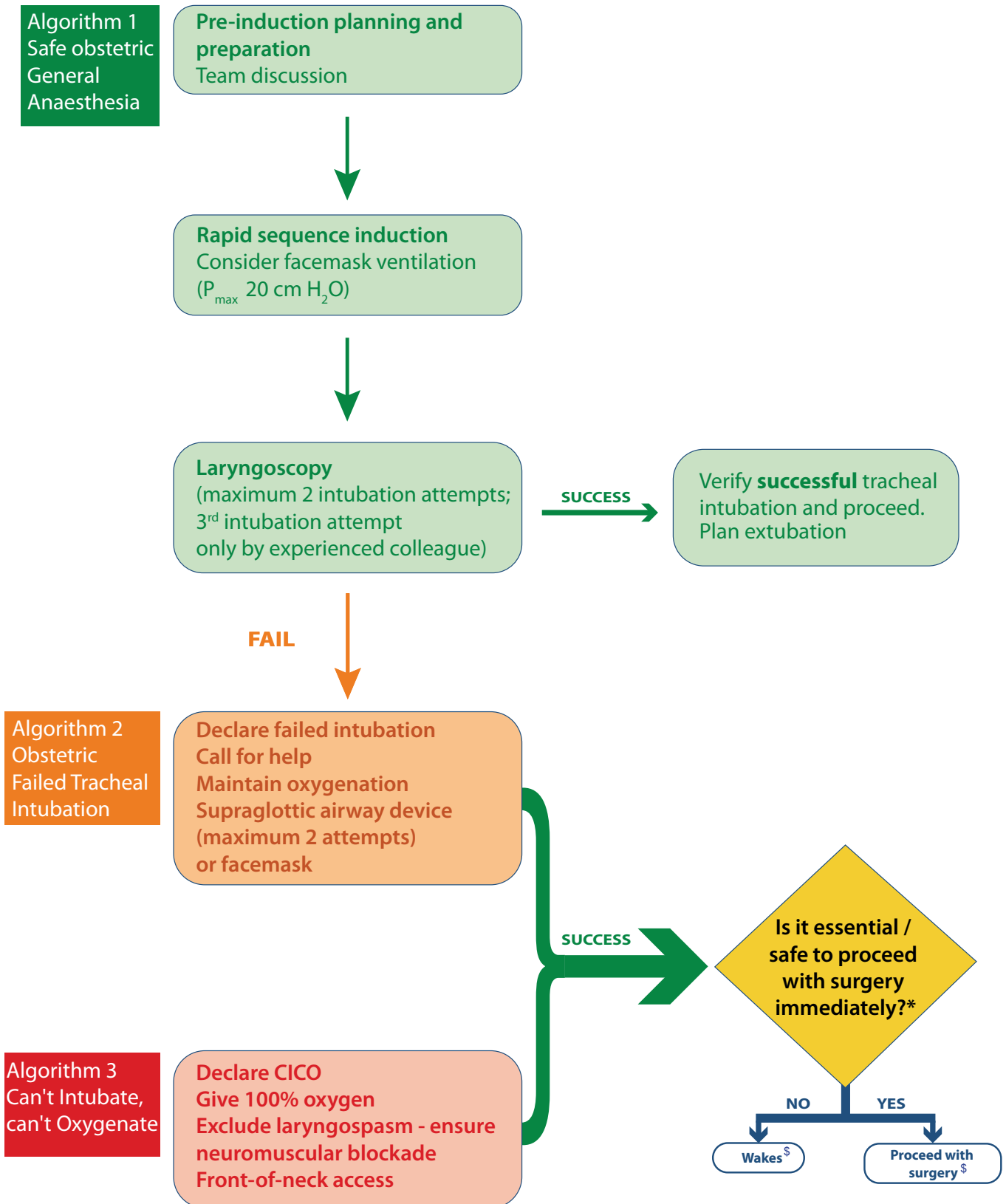
### **Difficult Airway:**

If intubation failed for two times by the same Anaesthesiologist.



- \* Call for help
- \* Ventilate with 100% oxygen.
- \* Use Facemask, LMA or Combitube.
- \* Assess ventilation and oxygenation.

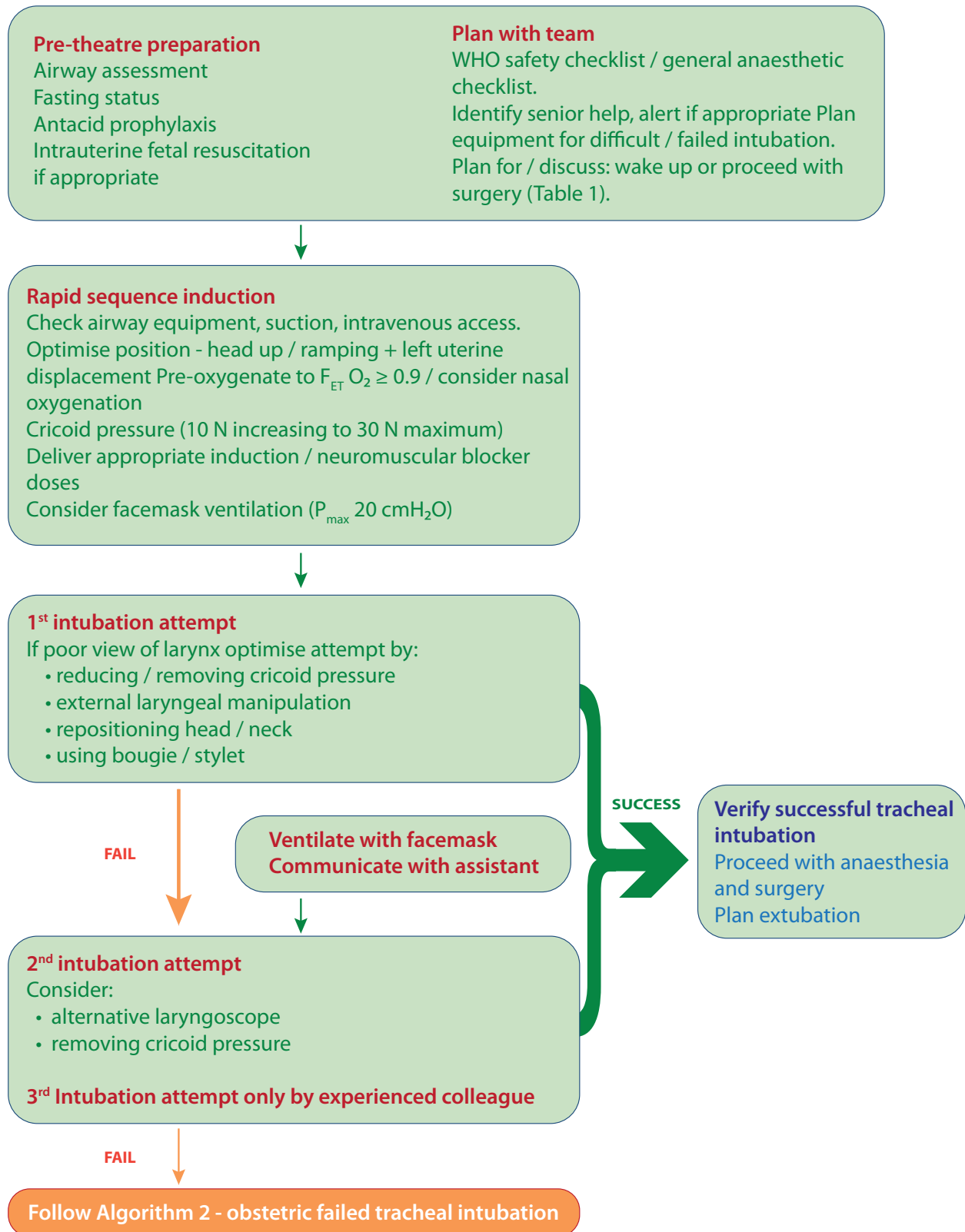
## Master algorithm - Obstetric General Anaesthesia and Failed Tracheal Intubation



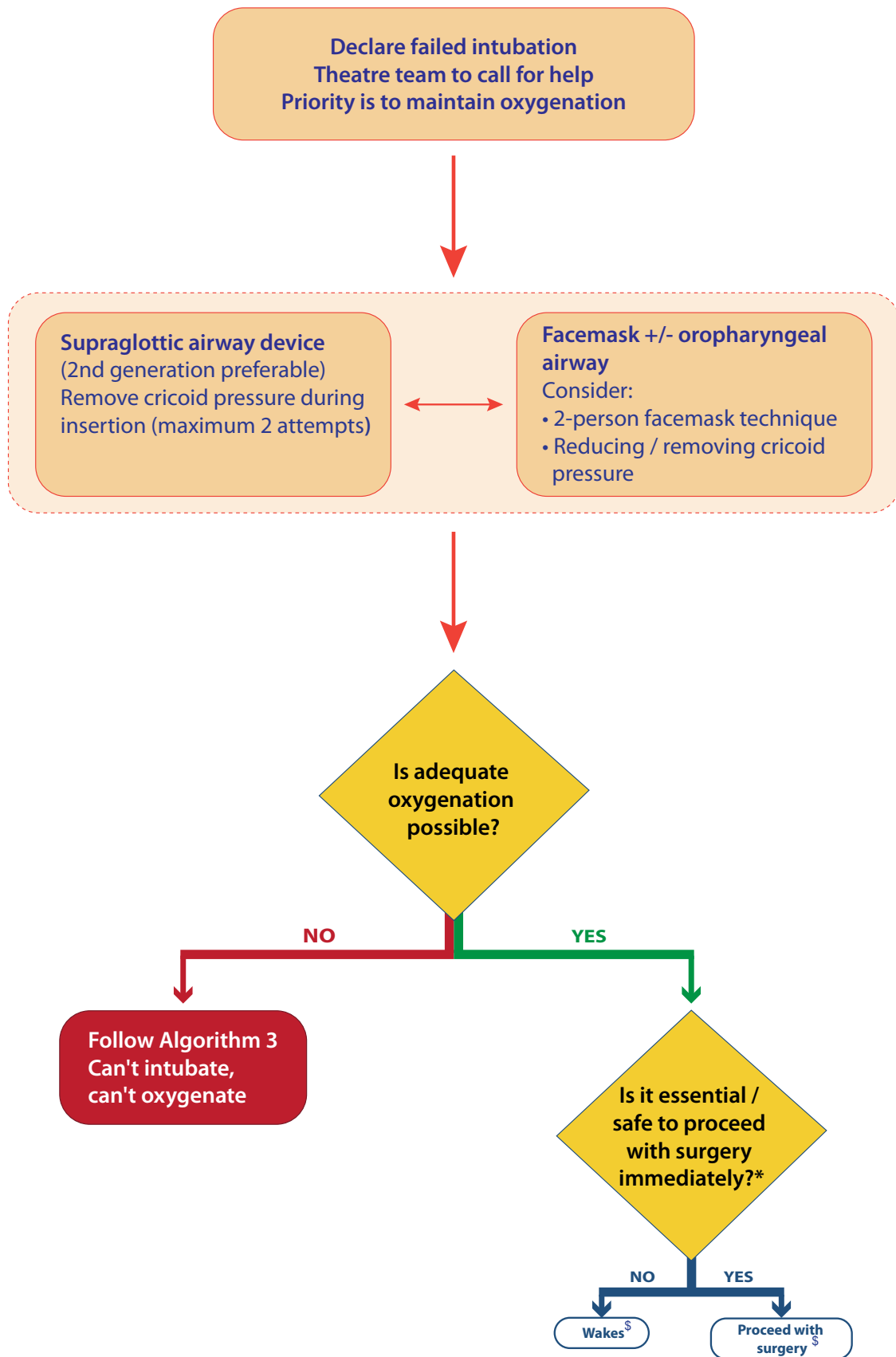
\*See Table 1, §See Table 2



## Algorithm 1 - Safe Obstetric General Anaesthesia



## Algorithm 2 - Obstetric Failed Tracheal Intubation



\*See Table 1, §See Table 2

### Algorithm 3 - can't intubate, can't oxygenate

Declare emergency to theatre team  
Call additional specialist help (ENT surgeon, intensivist)  
Give 100% oxygen  
Exclude laryngospasm - ensure neuromuscular blockade

Perform front-of-neck procedure

Is oxygenation restored?

NO

YES

Maternal advanced  
life support  
Perimortem caesarean  
section

Is it essential /  
safe to proceed  
with surgery  
immediately?\*

NO

YES

Wakes<sup>§</sup>

Proceed with  
surgery<sup>§</sup>

\*See Table 1, <sup>§</sup>See Table 2

**Table 1 - Proceed with Surgery?**

Factors to consider		WAKE	↔	PROCEED	
<b>Before induction</b>	<b>Maternal condition</b>	<ul style="list-style-type: none"> <li>No compromise</li> </ul>	<ul style="list-style-type: none"> <li>Mild acute compromise</li> </ul>	<ul style="list-style-type: none"> <li>Haemorrhage responsive to resuscitation</li> </ul>	<ul style="list-style-type: none"> <li>Hypovolaemia requiring corrective surgery</li> <li>Critical cardiac or respiratory compromise, cardiac arrest</li> </ul>
	<b>Fetal condition</b>	<ul style="list-style-type: none"> <li>No compromise</li> </ul>	<ul style="list-style-type: none"> <li>Compromise corrected with intrauterine resuscitation, pH &lt;7.2 but &gt; 7.15</li> </ul>	<ul style="list-style-type: none"> <li>Continuing fetal heart rate abnormality despite intrauterine resuscitation, pH &lt;7.15</li> </ul>	<ul style="list-style-type: none"> <li>Sustained bradycardia</li> <li>Fetal haemorrhage</li> <li>Suspected uterine rupture</li> </ul>
	<b>Anaesthetist</b>	<ul style="list-style-type: none"> <li>Novice</li> </ul>	<ul style="list-style-type: none"> <li>Junior trainee</li> </ul>	<ul style="list-style-type: none"> <li>Senior trainee</li> </ul>	<ul style="list-style-type: none"> <li>Consultant / specialist</li> </ul>
	<b>Obesity</b>	<ul style="list-style-type: none"> <li>Supermorbid</li> </ul>	<ul style="list-style-type: none"> <li>Morbid</li> </ul>	<ul style="list-style-type: none"> <li>Obese</li> </ul>	<ul style="list-style-type: none"> <li>Normal</li> </ul>
	<b>Surgical factors</b>	<ul style="list-style-type: none"> <li>Complex surgery or major haemorrhage anticipated</li> </ul>	<ul style="list-style-type: none"> <li>Multiple uterine scars</li> <li>Some surgical difficulties expected</li> </ul>	<ul style="list-style-type: none"> <li>Single uterine scar,</li> </ul>	<ul style="list-style-type: none"> <li>No risk factors</li> </ul>
	<b>Aspiration risk</b>	<ul style="list-style-type: none"> <li>Recent food</li> </ul>	<ul style="list-style-type: none"> <li>No recent food</li> <li>in labour</li> <li>opioids given</li> <li>Antacids not given</li> </ul>	<ul style="list-style-type: none"> <li>No recent food, In labour</li> <li>Opioids not given</li> <li>Antacids given</li> </ul>	<ul style="list-style-type: none"> <li>Fasted</li> <li>Not in labour</li> <li>Antacids given</li> </ul>
	<b>Alternative anaesthesia</b> <ul style="list-style-type: none"> <li>regional</li> <li>securing airway awake</li> </ul>	<ul style="list-style-type: none"> <li>No anticipated difficulty</li> </ul>	<ul style="list-style-type: none"> <li>Predicted difficulty</li> </ul>	<ul style="list-style-type: none"> <li>Relatively contraindicated</li> </ul>	<ul style="list-style-type: none"> <li>Absolutely contraindicated or has failed</li> <li>Surgery started</li> </ul>
<b>After failed intubation</b>	<b>Airway Device / Ventilation</b>	<ul style="list-style-type: none"> <li>Difficult facemask ventilation</li> <li>Front-of neck</li> </ul>	<ul style="list-style-type: none"> <li>Adequate facemask ventilation</li> </ul>	<ul style="list-style-type: none"> <li>First generation supraglottic airway device</li> </ul>	<ul style="list-style-type: none"> <li>Second generation supraglottic airway device</li> </ul>
	<b>Airway Hazards</b>	<ul style="list-style-type: none"> <li>Laryngeal oedema</li> <li>Stridor</li> </ul>	<ul style="list-style-type: none"> <li>Bleeding</li> <li>Trauma</li> </ul>	<ul style="list-style-type: none"> <li>Secretions</li> </ul>	<ul style="list-style-type: none"> <li>None evident</li> </ul>

Criteria to be used in the decision to wake or proceed following failed tracheal intubation. In any individual patient, some factors may suggest waking and others proceeding. The final decision will depend on the anaesthetist's clinical judgement. Obstetric Anaesthetists' Association / Difficult Airway Society (2015)

**Table 2 - management after failed tracheal intubation**

WAKE	Proceed with Surgery
<ul style="list-style-type: none"> <li>• Maintain oxygenation.</li> <li>• Maintain cricoid pressure if not impeding ventilation.</li> <li>• Either maintain head-up position or turn left lateral recumbent.</li> <li>• If rocuronium used, reverse with sugammadex.</li> <li>• Assess neuromuscular blockade and manage awareness if paralysis is prolonged</li> <li>• Anticipate laryngospasm / can't intubate, can't oxygenate</li> </ul>	<ul style="list-style-type: none"> <li>• Maintain anaesthesia.</li> <li>• Maintain ventilation - consider merits of:               <ul style="list-style-type: none"> <li>• controlled or spontaneous ventilation.</li> <li>• paralysis with rocuronium if sugammadex available.</li> </ul> </li> <li>• Anticipate laryngospasm / can't intubate, can't oxygenate.</li> <li>• Minimise aspiration risk:               <ul style="list-style-type: none"> <li>• maintain cricoid pressure until delivery (if not impeding ventilation).</li> <li>• after delivery maintain vigilance and reapply cricoid pressure if signs of regurgitation.</li> <li>• empty stomach with gastric drain tube if using second-generation supraglottic airway device.</li> <li>• minimise fundal pressure.</li> <li>• administer H<sub>2</sub> receptor blocker i.v. if not already given.</li> </ul> </li> <li>• Senior obstetrician to operate.</li> <li>• Inform neonatal team about failed intubation.</li> <li>• Consider total intravenous anaesthesia.</li> </ul>
AFTER WAKING	
<ul style="list-style-type: none"> <li>• Review urgency of surgery with obstetric team.</li> <li>• Intrauterine fetal resuscitation as appropriate.</li> <li>• For repeat anaesthesia, manage with two anaesthetists.</li> <li>• Anaesthetic options:               <ul style="list-style-type: none"> <li>• Regional anaesthesia preferably inserted in lateral position.</li> <li>• Secure airway awake before repeat general anaesthesia</li> </ul> </li> </ul>	

One must remember that the mother's life takes priority over the life of the fetus.

**KEY POINTS TO REMEMBER:**

- Preoperative airway assessment is compulsory for all patients coming for anaesthesia.
- Airway assessment includes the global or general examination, regional and radiologic assessment.
- A difficult airway cart should be equipped and ready for use in case of anticipated difficult intubation or an anticipated difficult airway.
- The answer to almost every difficult airway is 'Awake Intubation'.
- In case of anticipated difficult intubation, it is preferable to use a subarachnoid block.

**CHECK YOUR PROGRESS:**

- True/ False
  - The Mallampati test measures the tongue size with respect to that of the larynx. (T/F)

- b. The thyromental distance reflects the mandibular space. (T/F)
- c. The recommended position for LMA insertion is 'sniffing the morning air'. (T/F)
- d. Radiology cannot guide regarding the estimation of ease of intubation. (T/F)
- e. Oesophago-tracheal combitube is available in paediatric sizes. (T/F)

ii. Fill in the blanks

- a. Intubation is called difficult when an anaesthesiologist is unable to intubate in \_\_\_\_\_ attempts or \_\_\_\_\_ minutes.
- b. Laryngoscopy may be difficult if the thyromental distance is less than \_\_\_\_\_ cms.
- c. Sniff position is obtained by extension of \_\_\_\_\_ and flexion of \_\_\_\_\_.

iii. In the average size adult, the LMA used is

- a. 2.5
- b. 3
- c. 4
- d. 5

iv. In Carmack and Lehane grade 3

- a. Glottis is fully exposed.
- b. Posterior commissure only visualised.
- c. Epiglottis visualised.
- d. Not even epiglottis visualised.

v. Emergency cricothyrotomy is usually done with \_\_\_\_\_ size needle.

- a. 12-16 G
- b. 18-20 G
- c. 20-24 G

**ANSWERS:**

- i. (a) F      (b) T      (c) T      (d) F      (e) F
- ii. (a) 3, 10      (b) 6      (c) Head, Cervical Spine
- iii. C
- iv. C
- v. A

**Further findings:**

- Obstetric anaesthesia – Chestnut.
- Airway Management – Benumof.

# Week 4 - Module

## Oxygen Therapy, Spinal and General Anesthesia





# 12

## Oxygen Therapy

---

### OBJECTIVES

After reading this chapter, one would be able to:

- Describe when oxygen (O<sub>2</sub>) therapy is needed.
- Assess the need for O<sub>2</sub> therapy.
- Describe what precautions and complications are associated with O<sub>2</sub> therapy.
- Select an O<sub>2</sub> delivery system appropriate for the respiratory care plan.
- Describe how to administer O<sub>2</sub> systems.
- Assess and monitor a patient's response to O<sub>2</sub> therapy

### INTRODUCTION:

Oxygen is in the air we breathe and is necessary to live. The three basic nutrients without which planet earth could not exist as a home for living things are Oxygen, Light and Water.

Oxygen may be classified as an element, a gas and a drug.

### DEFINITION:

Oxygen therapy is the administration of oxygen at concentrations greater than that in room air to treat or prevent hypoxaemia (Not enough oxygen in the blood).

### Purpose:

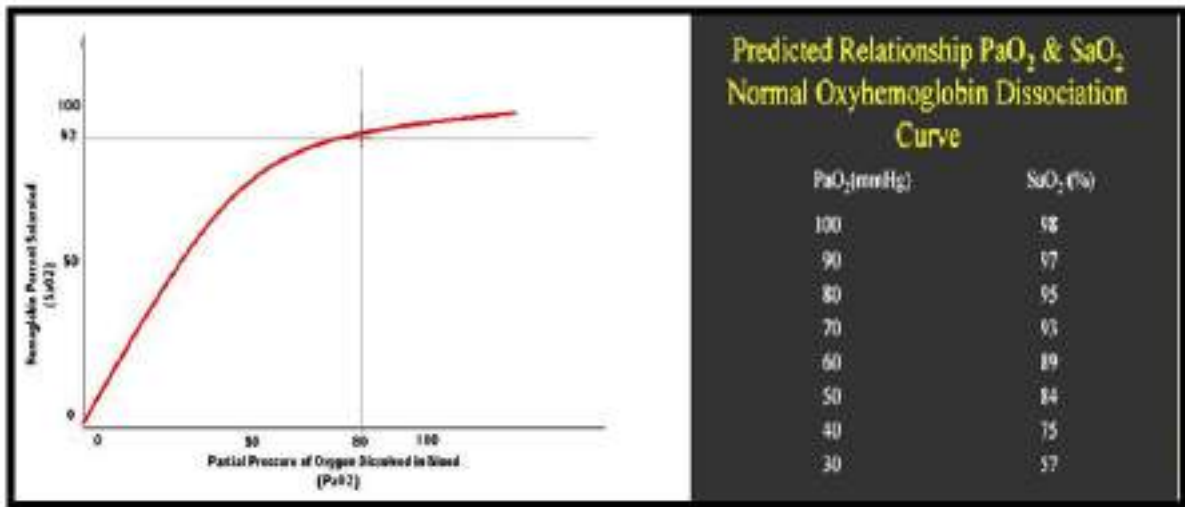
- The body is constantly taking in O<sub>2</sub> & releasing CO<sub>2</sub>. If this process is inadequate, oxygen levels in the blood decrease, and the patient may need supplemental oxygen. Oxygen therapy is a key treatment in respiratory care.
- The purpose is to increase oxygen saturation in tissues where the saturation levels are too low due to illness or injury.

### OXYHAEMOGLOBIN DISSOCIATION CURVE:

- **Definition:** A relationship between the amount of oxygen dissolved in the blood and the amount attached to the hemoglobin. This is called the normal Oxyhemoglobin dissociation curve.
- Oxygen can be measured in two forms:
  - The partial atmospheric pressure of oxygen (PaO<sub>2</sub>).

- Oxygen saturation (SaO<sub>2</sub>).
- Calculated estimate of oxygen saturation (SpO<sub>2</sub>): an indirect SaO<sub>2</sub>.

### Normal Oxyhemoglobin Dissociation Curve:

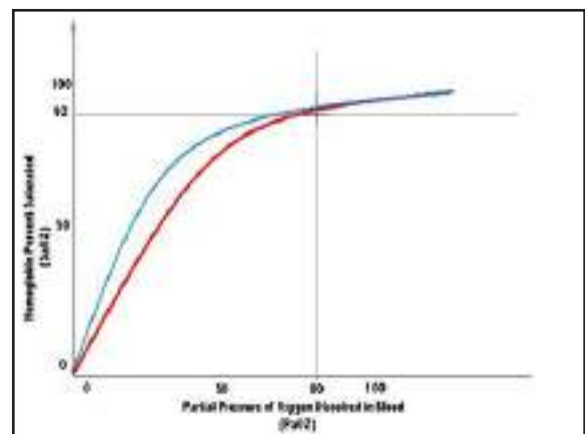


- 97% Saturation = 97 PaO<sub>2</sub> (Normal).
- 90% Saturation = 60 PaO<sub>2</sub> (Danger).
- 80% Saturation = 45 PaO<sub>2</sub> (Hypoxia).

Reference Ranges	Arterial Blood	Venous Blood
pH	7.35 - 7.45	7.35 - 7.43
pCO <sub>2</sub>	35 - 45 mmHg	38 - 50 mmHg
pO <sub>2</sub>	80 - 100 mmHg	30 - 50 mmHg
HCO <sub>3</sub>	22 - 26 mm	23 - 27 mm
O <sub>2</sub> Saturation	95 - 100%	60 - 85%

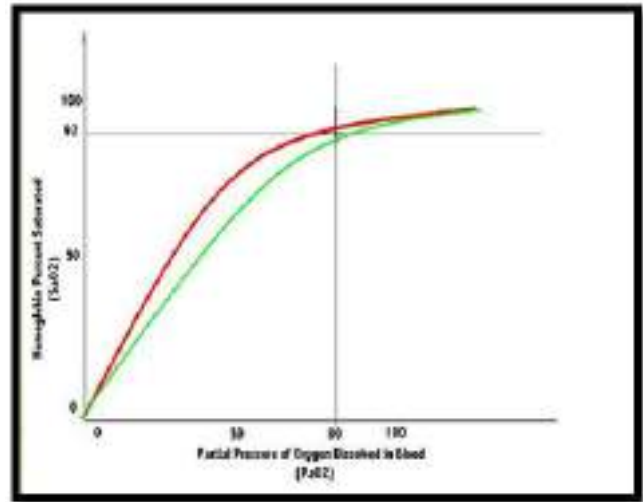
### Shift to Left:

- Increase in pH.
- Decrease in CO<sub>2</sub>.
- Decrease in 2,3-DPG.
- Decrease in temperature.



### Shift to Left:

- Increase in pH.
- Decrease in CO<sub>2</sub>.
- Decrease in 2,3-DPG.
- Decrease in temperature.



### MARKERS OF O<sub>2</sub> MONITORING:

- $PiO_2 = (760 - 47) \times 0.21 = 150 \text{ mmHg}$ .
- $FiO_2 = 0.21$ .
- $PAO_2 = 100 \text{ mmHg}$ .
- $PaO_2 = 90 \text{ mmHg}$ .
- $SaO_2 = O_2$  saturation derived from arterialised capillary blood.
- $SpO_2 = O_2$  saturation by pulse oximeter

### OXYGEN FLUX AND REQUIREMENTS:

The supply of oxygen is dependent upon the haemoglobin (Hb), O<sub>2</sub> saturation % (SaO<sub>2</sub>) and cardiac output (Q).

“Oxygen flux” denotes the total amount of oxygen delivered to the body per minute and is given by the equation:

$$\text{Oxygen flux} = 1.34 \times \text{Hb in g/dL} \times (\text{SaO}_2/100) \times (\text{Q in mL/min})/100 = 1000 \text{ mL/min.}$$

### ASSESSMENT OF NEED:

Need is determined by measurement of inadequate oxygen tensions and/or saturations, by invasive or noninvasive methods, and/or the presence of clinical indicators as previously described.

- Arterial blood gases.
- Pulse oximetry.
- Clinical presentation.

### How to Assess Oxygenation?

- Arterial blood gases.
- Pulse oximetry.

### Errors in Pulse Oximetry:

- Artificial fingernails. ▶ Nail Polish.
- Dark pigmentation. ▶ Pulsatile Venous System.
- Electrical. ▶ Radiated light.
- Intravenous dyes. ▶ Oedema.
- Movement.

### INDICATIONS OF O<sub>2</sub> THERAPY:

#### 1. Documented Hypoxaemia:

In adults, children, and infants older than 28 days, arterial oxygen tension (PaO<sub>2</sub>) of < 60 mmHg or arterial oxygen saturation (SaO<sub>2</sub>) of < 90% in subjects breathing room air or with PaO<sub>2</sub> and/or SaO<sub>2</sub> below desirable range for the specific clinical situation. In neonates, PaO<sub>2</sub> < 50 mmHg and/or SaO<sub>2</sub> < 88% or capillary oxygen tension (PcO<sub>2</sub>) < 40 mmHg.

2. An acute care situation in which hypoxaemia is suspected substantiation of hypoxaemia is required within an appropriate period of time following initiation of therapy.
3. Severe trauma.
4. Acute myocardial infarction.
5. Short-term therapy (e.g., Post-anaesthesia recovery).
6. Increased metabolic demands, i.e. burns, multiple injuries, severe infections.

#### \* Goal-Directed Approach:

- Post-Operative (Thoracic/Abdominal Surgery).
- Post-Extubation.
- Conscious State / Coughing.
- Redistribution of Fluid.
- Positioning.

### THREE CLINICAL GOALS OF O<sub>2</sub> THERAPY:

1. Treat hypoxaemia.
2. Decrease Work of Breathing (WOB).
3. Decrease in Myocardial Work.

### FACTORS THAT DETERMINE WHICH SYSTEM TO USE:

1. Patient comfort/acceptance by the patient.
2. The level of FiO<sub>2</sub> that is needed.

3. The requirement that the  $\text{FiO}_2$  be controlled within a certain range.
4. The level of humidification and /or nebulisation.
5. Minimal resistance to breathing.
6. Efficient & economical use of oxygen.

## O<sub>2</sub> DELIVERY METHODS:

- Low Flow Oxygen Delivery System (Variable Performance).
- High Flow Oxygen Delivery System (Fixed Performance).

## Classification

- According to design
  - Low flow- The gas flow of apparatus is insufficient to meet all inspiratory requirements.
  - Reservoir- Stores a reserve volume that equals or exceeds the patient tidal volume.
  - High flow- The gas flow of the apparatus is sufficient to meet all inspiratory requirements.
  - Enclosure.
- According to performance
  - Variable- If the system provides only some of the inspired gas, the patient draws the remaining from surrounding air.
  - Fixed- If the system provides all the patient's inspired gas.
- According to oxygen concentration

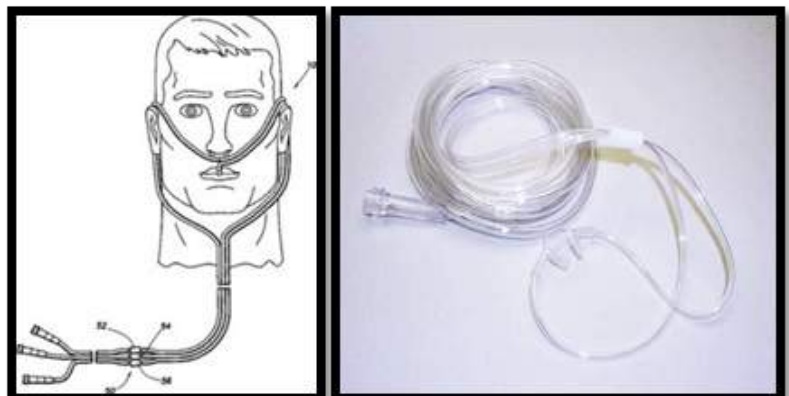
## LOW FLOW OXYGEN DELIVERY SYSTEM:

### $\text{FiO}_2$ depends on O<sub>2</sub> flow, patient factors and device factors:

- Nasal cannula.
- Simple face mask.
- Partial rebreathing mask.
- Non-rebreathing mask.

### \* Nasal Cannula:

- Simple plastic tubing + prongs.
- Flow from 1-6 LPM of O<sub>2</sub>.
- $\text{FiO}_2$  ranges from 24-44% of O<sub>2</sub>.
  - 1 - 24%.
  - 2 - 28%.
  - 3 - 32%.
  - 4 - 36%.
  - 5 - 40%.
  - 6 - 44%.
- Correct placement.
- No nasal obstruction.



## Errors in Pulse Oximetry:

Advantages	Disadvantages
<ul style="list-style-type: none"><li>• Inexpensive.</li><li>• Well tolerated, Comfortable.</li><li>• Easy to eat, drink.</li><li>• Used in patients with COPD.</li><li>• Used with humidity.</li></ul>	<ul style="list-style-type: none"><li>• Pressure sores.</li><li>• Crusting of Secretions.</li><li>• Drying of Mucosa.</li><li>• Epistaxis.</li></ul>

### \* Simple Face Mask:

The placing of a mask over the patient's face increases the size of the oxygen reservoir beyond the limits of the anatomic reservoir; therefore, a higher  $FiO_2$  can be delivered.

The oxygen flow must be run at a sufficient rate, usually 5 litres/minute or more to prevent rebreathing of exhaled gases.

#### Advantages:

Simple, Lightweight,  $FiO_2$  up to 0.60, Can be used with humidity.

#### Disadvantages:

Need to remove when Speak, Eat, Drink, Vomiting, Expectoration of Secretions, Drying/irritation of eyes, Uncomfortable when Facial burns / Trauma application problem when RT in SITU.



### \* Partial Rebreathing Bag:

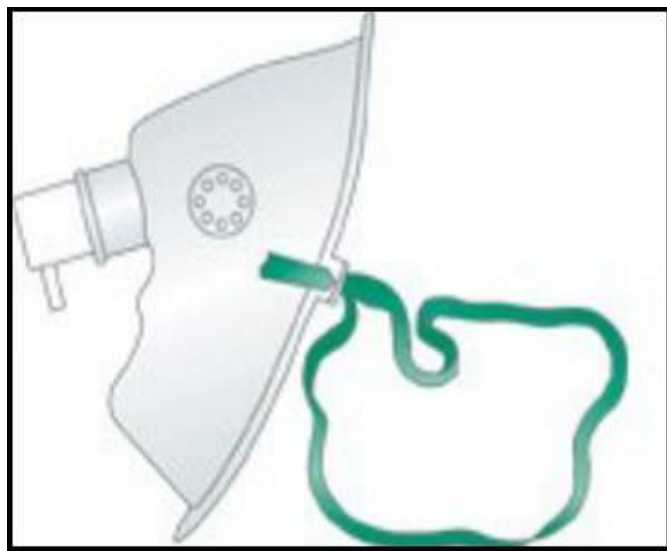
#### Advantages:

$FiO_2$  delivered  $>0.60$  is delivered in moderate to Severe Hypoxia, Exhaled oxygen from anatomic dead space is conserved.

#### Disadvantages:

The insufficient flow rate may lead to rebreathing of  $CO_2$ , Claustrophobia; Drying and irritation of eyes.

To avoid rebreathing, a flow of at least 5 L/minute should be used with  $O_2$  masks; for reservoir masks with bags, the flow must be sufficient to prevent bag collapse.



\* **Non-rebreathing Bag:**



**HIGH FLOW OXYGEN DELIVERY SYSTEM:**

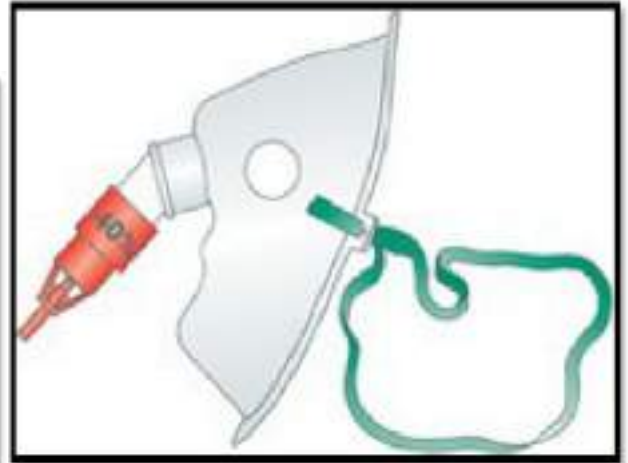
- Venturi mask.
- Face tent.
- Aerosol mask.
- Tracheostomy collar.
- T-piece.

\* **Venturi Valve:**

Colour	FiO <sub>2</sub>	O <sub>2</sub> Flow
Blue	24%	2 L/min
White	28%	4 L/min
Orange	31%	6 L/min
Yellow	35%	8 L/min
Red	40%	10 L/min
Green	60%	15 L/min



\* **Venturi Mask:**



Face Tent



Tracheostomy Collar



A high-flow nasal cannula (HFNC) can be useful in treating moderate hypoxaemia, especially for patients who do not tolerate oxygen masks and need supplemental humidity.

**HAZARDS & COMPLICATIONS OF OXYGEN THERAPY:**

- Oxygen-induced hypoventilation.
- Oxygen toxicity/O<sub>2</sub> narcosis.
- Absorption atelectasis.
- Retinopathy of prematurity
- Drying of mucous membranes.
- Infection.

**KEY POINTS TO REMEMBER**

\* O<sub>2</sub> therapy is used to (1) correct acute hypoxaemia, (2) decrease the symptoms of chronic

hypoxaemia, and (3) decrease cardiopulmonary workload.

- The need for supplemental O<sub>2</sub> can be assessed with laboratory measures, clinical history, and bedside patient evaluation
- The three Ps—purpose, patient, and performance of the device—should be considered in the selection or recommendation of an O<sub>2</sub> delivery system

### CHECK YOUR PROGRESS:

1. What is the first thing that should be done when administering oxygen?
  - a. Attach the delivery device
  - b. Fill the reservoir bag
  - c. Open the main valve
  - d. Explain the need for oxygen therapy
2. Approximately what percentage of oxygen is found in the air, we exhale?
  - a. 16%
  - b. 100%
  - c. 21%
  - d. 19%
3. Which oxygen-delivery device consists of two small plastic prongs?
  - a. Nasal cannula
  - b. Rebreather mask
  - c. Blow-by device
  - d. Nonrebreather mask

### ANSWER-

1. D
2. A
3. A

### Further Findings:

- Egan's respiratory care

# 13,14 &15

- **Physiology of spinal anesthesia**
- **Spinal Anaesthesia**
- **General anaesthesia**

---

## INTRODUCTION:

Obstetric anaesthesia is a demanding and gratifying subspecialty of Anaesthesiology. Most patients are young and healthy. The obstetric patients differ from their nonpregnant counterparts by the physiological changes of pregnancy and the presence of a foetus, both being affected by anaesthesia. The process is risky, and the death of a young and healthy individual would lead to disastrous consequences not only for the family but also for the society. Medico-legal consequences of this type of patients are in a rising trend. Therefore, complete knowledge and adequate skill are required to handle this type of special situation.

## OBJECTIVES:

After going through this module, one should be able to:

- Describe the guidelines regarding the administration of general or regional anaesthesia for the emergency obstetric procedure.
- Describe important considerations to be kept in mind while anaesthetising a patient for emergency caesarean section.

### \* **Pre anaesthesia check-up:**

- History in these patients is very important.
- Any events during pregnancy should be noted.
- Any co-existing disease.
- Coordination with the obstetrician is vital for the management of cases.

### \* **REGIONAL ANAESTHESIA:**

Regional anaesthesia provides the labouring mother to have the most effective and reliable method of pain relief. The mother remains awake and able to participate in the birth.

#### i. **Choice of the drugs for the regional anaesthesia:**

**Local Anaesthetics** - Bupivacaine, Lignocaine.

**Opioids** as adjuvants to improve quality and duration – Morphine, Fentanyl, Sufentanil,

Dexmedetomidine.

ii. Individual techniques

**For Regional Anaesthesia.**

**\* SPINAL ANAESTHESIA:**

• **Definition:**

- Spinal Anaesthesia is the regional anaesthesia obtained by blocking (anaesthetising) the spinal nerves in the subarachnoid space.
- The anaesthetic agents are given in the subarachnoid space & act on the spinal nerve roots.

• **History:**

- Corning was first to administer spinal anaesthesia in 1885.
- It was first used by Bier for providing surgical anaesthesia in 1898.

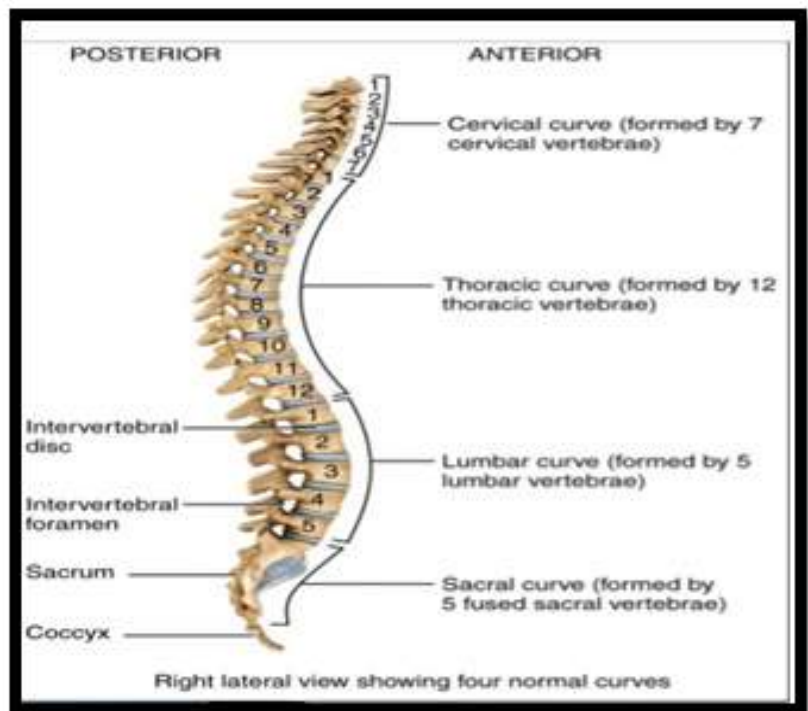
• **Vertebral Column:**

Total 33 Vertebrae:

- 7 Cervical.
- 12 Thoracic.
- 5 Lumbar.
- 5 Sacral & 4 Coccygeal.

• **Has 4 Curves:**

- Cervical & Lumbar:  
Convex anteriorly
- Thoracic & Sacral:  
Convex posteriorly

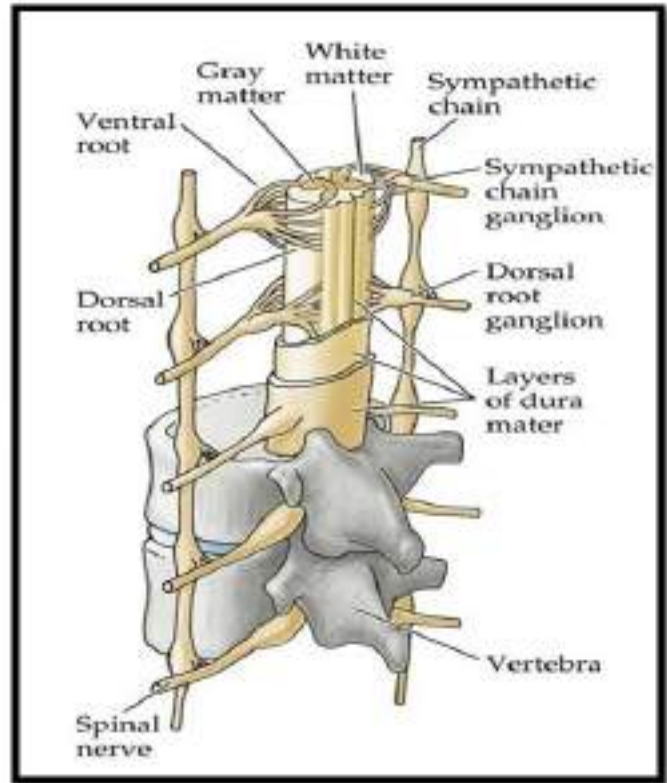
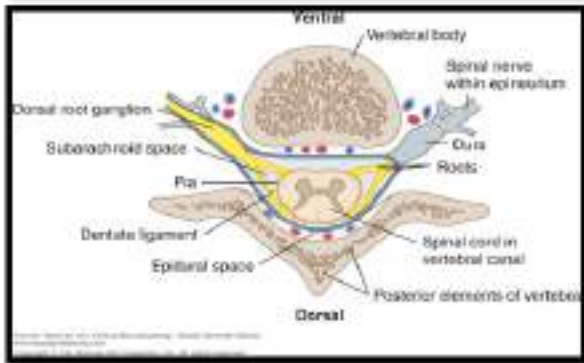
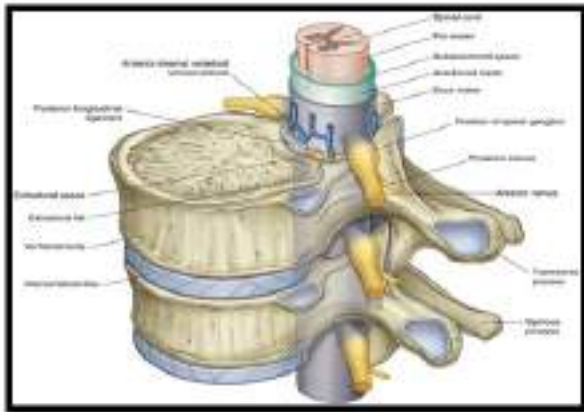


• **Vertebral Canal:**

• **Boundaries are:**

- ▶ Anteriorly : Vertebral body and intervertebral disc.
- ▶ Laterally : Pedicles.
- ▶ Posteriorly: Lamina, Ligamentum flavum.

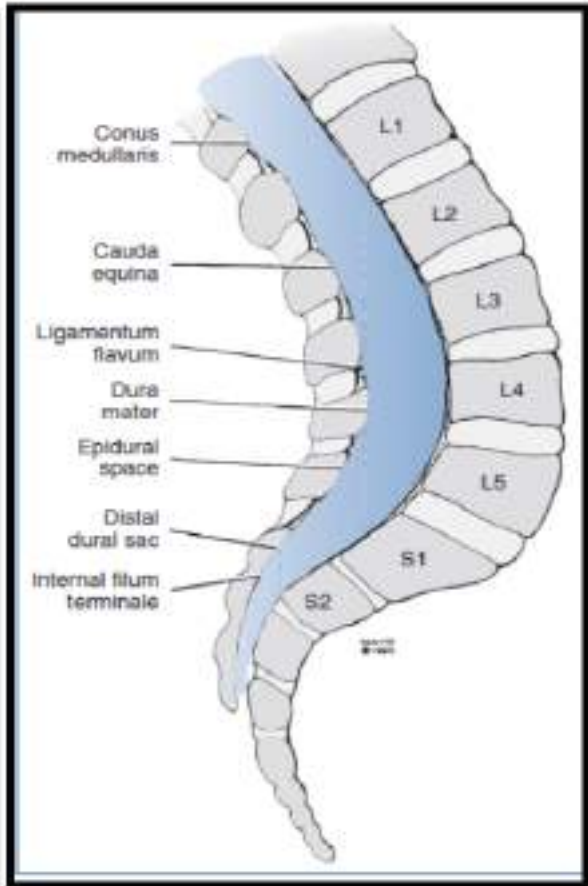
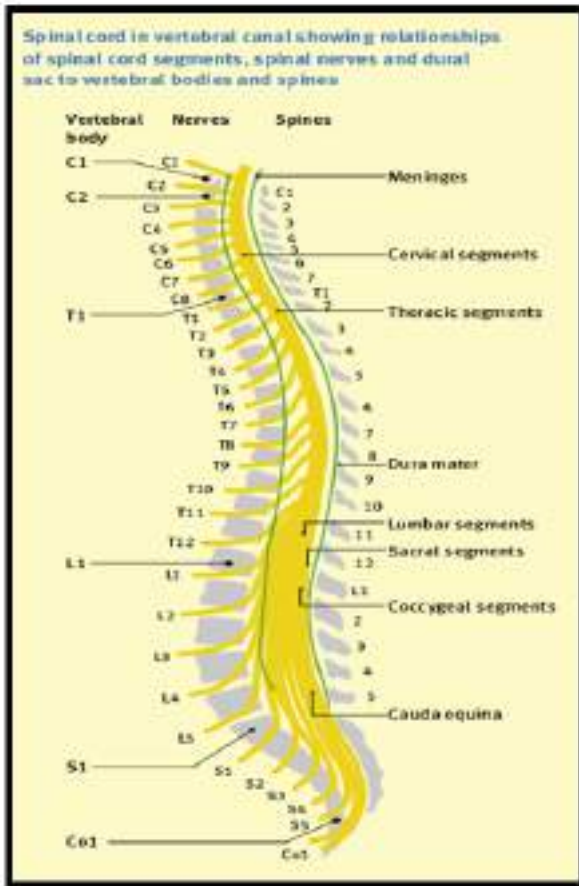
• Spinal cord with Meninges, Nerve roots, their Vessels and Epidural space lie in the vertebral canal.



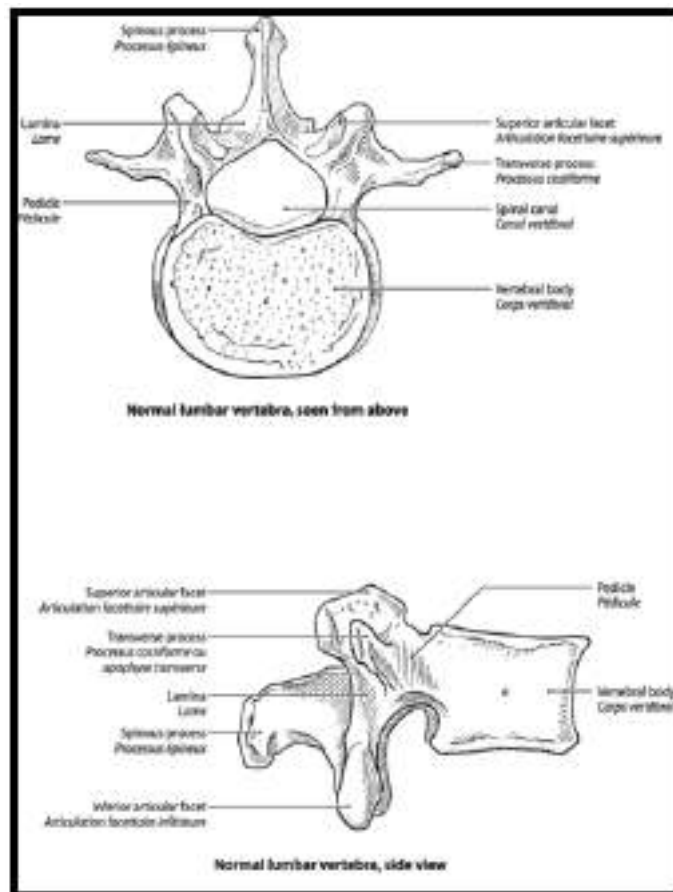
- **Meninges:**

The spinal cord is enveloped from inside to outside:

- **Pia mater:**  
Extends as Filum Terminale.
- **Arachnoid:**  
Closely applied to dura.
- **Dura:**  
Extends upto S2 in adults & S4 in infants. The inner layer is firmly adherent to foramina magnum so drug deposited in epidural space cannot enter the cranial cavity.

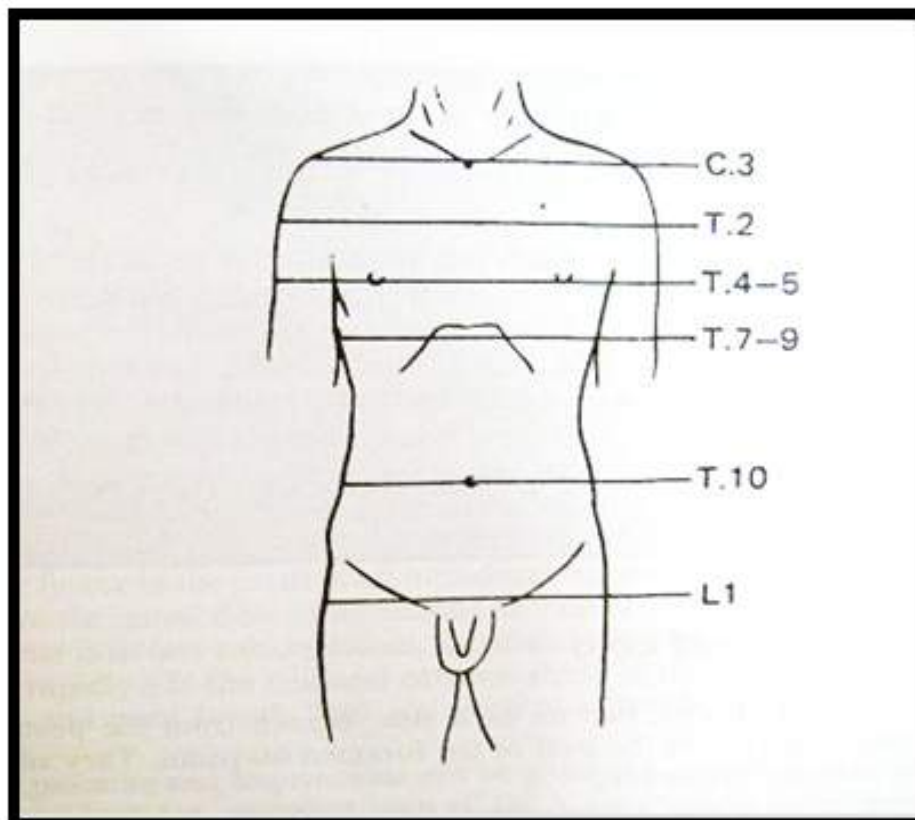


- Lumbar Vertebra:





- **Spinal Nerves:**
  - The spinal cord is divided into segments by spinal nerves which arise from it.
  - Spinal Nerves - 31 pairs:
    - ▶ 8 Cervical
    - ▶ 12 Thoracic
    - ▶ 5 Lumbar
    - ▶ 5 Sacral & 1 Coccygeal.
  - Spinal Nerve:
    - Anterior root : Efferent & motor
    - Posterior root : Afferent & sensory
- **Dermatological Segment:**
  - Nipples : T4
  - Xiphisternum : T6
  - Umbilicus : T10
  - Inguinal ligament : L1
  - Perineum : S1 - S4
- **Level required for Caesarean Section: T4-T6**
- Minimises discomfort of splanchnic handling.



- **Segmental Level of Spinal Reflexes:**

- Epigastric : T6-7
- Abdominal : T9-12
- Cremasteric : L1-2
- Knee jerk : L2-4
- Ankle jerk : S1-2
- Plantar : S1-2
- Anal sphincter : S4-5

- **Blood Supply:**

- 2 Posterior spinal arteries arising from Posterior inferior cerebellar arteries: Supply posterior column.
- 1 Anterior spinal artery branch of the vertebral artery: Supplies anterior & lateral column & grey matter.
- Thrombosis of this vessel causes anterior spinal artery syndrome: Paraplegia without loss of posterior column sensation (Joint position, Touch & Vibration sense).
- Hypotension, Local Vasoconstriction, Thrombosis, Aortic clamping or damage to the artery by needle lead to cord Ischaemia & Paraparesis to Paraplegia.
- Spinal veins comprise Anterior & Posterior Plexus which drain through Intervertebral foramina into Vertebral, Azygous & Lumbar veins.

- **Anatomical Changes of Pregnancy:**

- Uterine enlargement and vena cava compression result in engorgement of the epidural veins.
- Enlarged epidural veins & greater intra-abdominal pressure of pregnancy: Lowered dose requirement for spinal anaesthesia in pregnant women.
- Less dense, Softer ligamentum flavum.
- Higher sensory levels.

- **Contraindications of Spinal Anaesthesia:**

**Absolute:**

- Patient refusal.
- Sepsis at the site of injection.
- Coagulopathy.
- Indeterminate neurologic disease.
- Increased intracranial pressure.

**Absolute:**

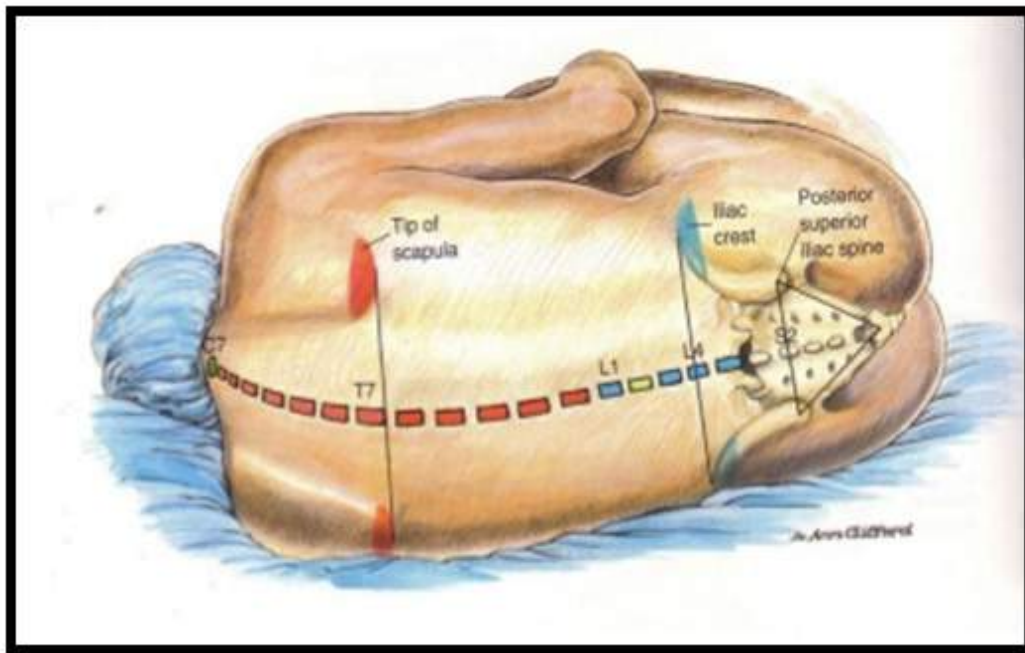
- Hypovolemia- can be administered only after the correction.
- Infection distinct from the site of injection.
- Unknown or prolonged duration of surgery.

- **Anatomy for Spinal Anaesthesia:**

- Spinal cord usually ends at L2 in adults.
- Dural puncture above these levels is associated with the risk of damaging the spinal cord and is best avoided.



- Important landmark: Line joining the top of iliac crests is at L4 spine or L4/5 space.



- **Positioning the Patient for Lumbar Puncture:**

Sitting and Lateral Position:

Lumbar puncture is most easily performed when there is maximum flexion of the spine.

- **Sitting:**

- Best achieved by sitting on operating table, keeping feet on a stool & resting forearms on the thighs.
- Preferable position in obese patients.

- **Lateral:**

- Patient lying on the side with hips & knees maximally flexed.
- Assistant help to maintain the patient in a comfortable curled position.
- Better position for uncooperative & sedated patients.

- **Approaches:**

- Median - Most commonly done, Best for the beginners.

- **Others:**

- Paramedian, Taylor.

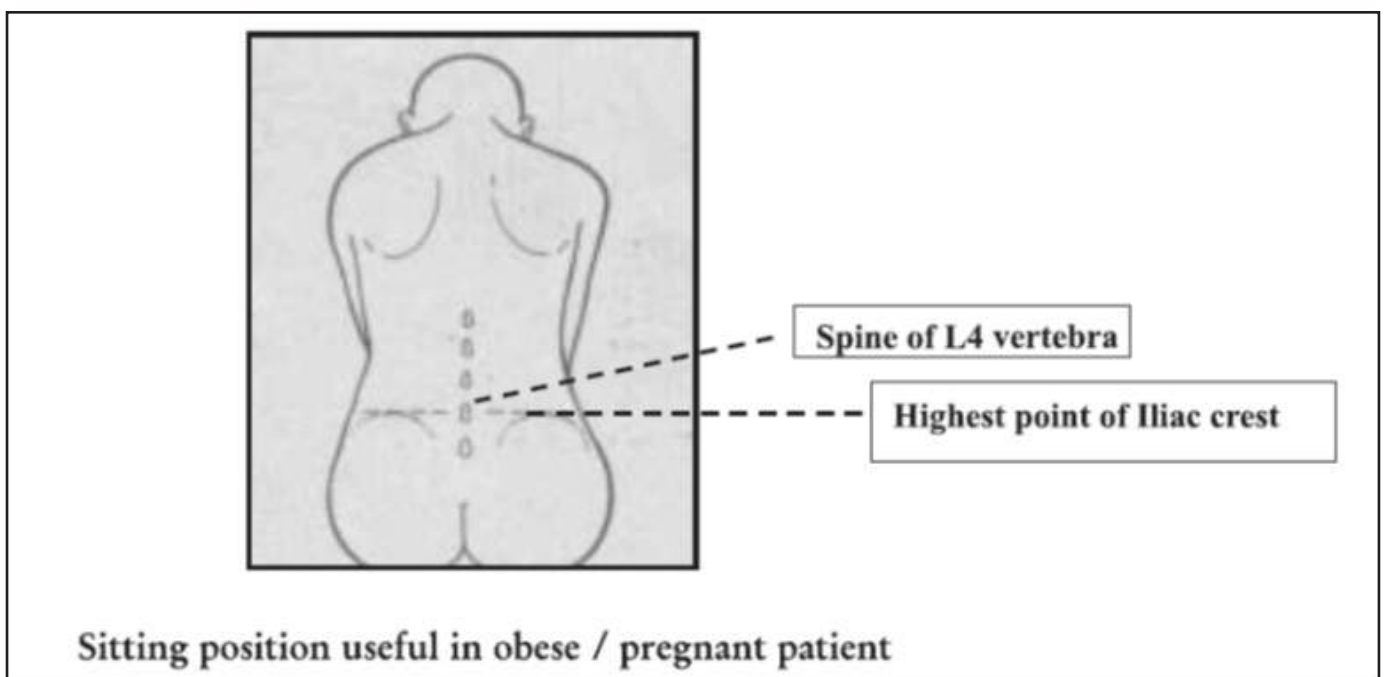
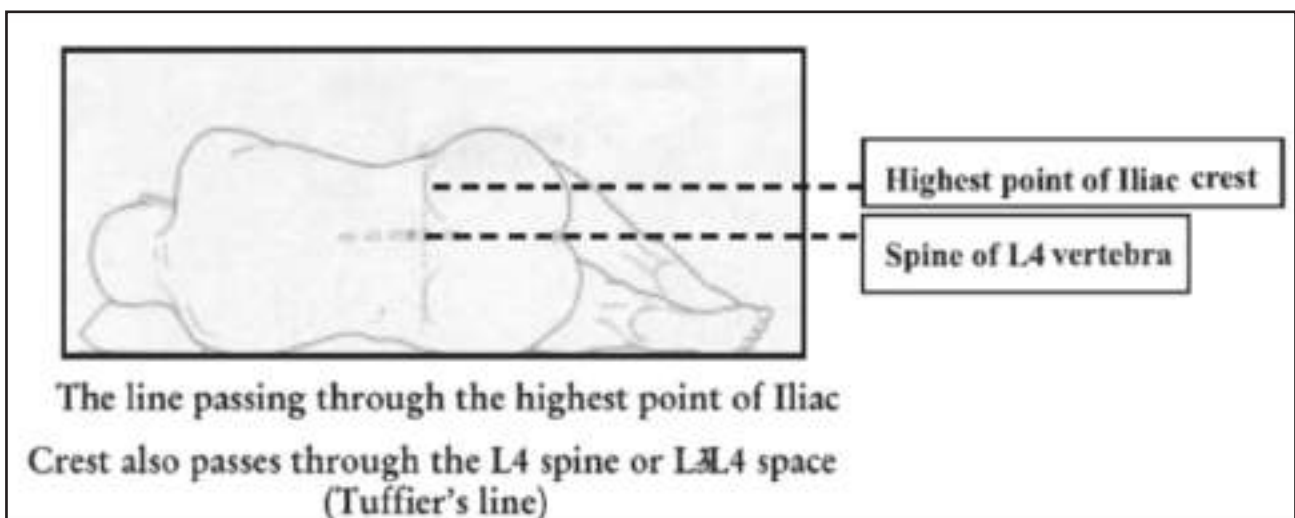
- **The volume of drug required:**

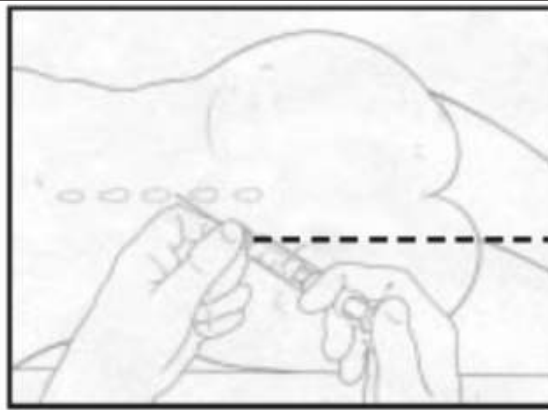
- 1.8 to 2.2 ml of 0.5 % Bupivacaine (Heavy).

- **Spinal anaesthesia technique:**

- Ensure intravenous access with large bore cannula; start an infusion of lactated Ringer's solution up to 1000 ml to 1500 ml.

- Monitor foetal heart rate.
- Place the patient in the lateral decubitus position or sitting position as preferred.
- Disinfect the skin using Chlorhexidine or betadine and spirit.
- Locate the space.
- Insert the spinal needle (25G / 26) in desired space, gradually penetrate millimetre wise till dura is punctured and CSF is detected at the needle hub.
- Administer 1.5 ml to 2 ml of 0.5% heavy bupivacaine.
- Make the patient supine from lateral decubitus position without losing much time; maintaining left lateral tilt.
- Monitor heart rate continuously, blood pressure every 2 minutes to start with then every 5 minutes till 20 minutes.



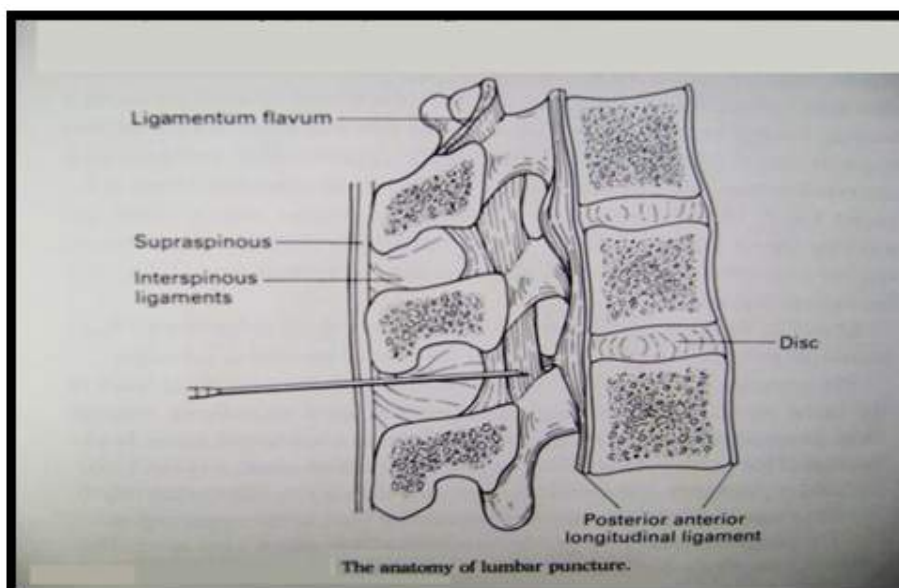


Drug being injected into sub archnoid space after confirming aspiration of clear fluid

Note The hand should not move during injection

- **Structures that needle will Pierce Before Reaching CSF:**

- Skin.
- Subcutaneous fat.
- Supraspinous Ligament: Joins tips of spinous processes together.
- Interspinous Ligament: Thin flat band of the ligament running between spinous processes.
- Ligamentum flavum: Thick up to 1 cm in the midline. Mostly composed of elastic tissue. Runs vertically from lamina to lamina. A distinct "give" can often be felt as it passes through this into epidural space. Similar "give" may be felt when the needle is advanced a short distance further and pierces dural sac.
- Subarachnoid Space:
- Contains spinal cord & nerve roots surrounded by CSF. An injection of local anaesthetic will mix with CSF & block nerve roots with which it comes in contact.



• Differences Between Spinal and Epidural Block:

Spinal:	Epidural:
Given at level below L1-L2.	Given at any level of vertebral column.
Drug injected after puncture of the dura mater.	Drug is deposited in between ligamentum flavum and dura mater without puncturing the dura.
Identification of subarachnoid space- when CSF appears.	Identification of epidural space- loss of resistance to air/ saline.
Low dose of hyperbaric (Heavy) bupivacaine etc.	Requires higher dose (10-20 ml).
Onset of action - Fast (2-5 minutes).	Onset of action - Slow (15-20 minutes).
Density of block - Denser.	Density of block - Less dense.
Hypotension - More and early.	Hypotension- Less with the graded epidural.
Duration – Short.	Duration can be prolonged with a catheter.
Post-Dural Puncture Headache (PDPH) can happen.	Post-Dural Puncture Headache (PDPH) chances almost nil.

Neuraxial Technique	Advantages	Disadvantages
Single - Shot spinal	<ul style="list-style-type: none"> <li>• Technically simple.</li> <li>• Rapid onset of analgesia.</li> <li>• Immediate sacral analgesia.</li> <li>• Low drug doses.</li> </ul>	<ul style="list-style-type: none"> <li>• Limited duration of anaesthesia/ analgesia.</li> </ul>
Continuous epidural	<ul style="list-style-type: none"> <li>• Continuous analgesia.</li> <li>• No dural puncture required.</li> <li>• Ability to extend analgesia/ anaesthesia.</li> </ul>	<ul style="list-style-type: none"> <li>• Slow onset.</li> <li>• Larger dose requirement.</li> <li>• Greater risk for maternal systemic toxicity.</li> <li>• Greater foetal drug exposure.</li> </ul>

- **Factors Affecting Block Height:**

**Important:**

- Baricity, dose, volume and specific gravity of the local anaesthetic solution.
- Position during and after injection: More spread with Trendelenburg position.
- Decreased CSF volume (increased intra-abdominal pressure due to Increased weight, Pregnancy, Old age etc.).
- Epidural injection post spinal.

**Less Important:**

- Height (very short or tall).
- Weight.
- Spinal column anatomy.
- Needle type and orifice direction.
- Increased abdominal pressure.
- Viscosity and temperature of injection.

**Not Important:**

- Additives other than opioids.
- Gender.
- Menopause.

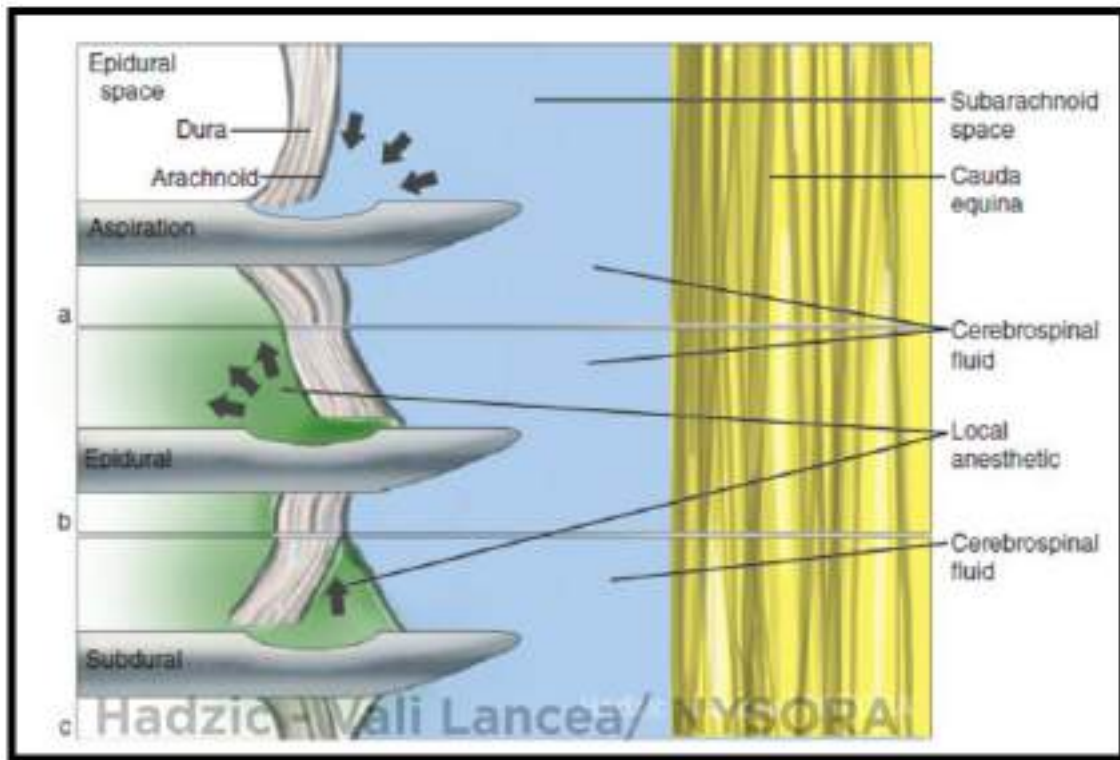
- **Reasons for Failed Spinal Anaesthesia:**

**Modifiable:**

- Wrong drug, Error in the judgement of the dose of local anaesthetics, Bupivacaine samples from ineffective batch .
- Needle displacement during drug injection, loss of injectate.
- Exteriorisation of the uterus.

**Non- modifiable:**

- Lumbosacral CSF volume variation, Intrathecal septae, Sacral maldistribution of LA.
- Pseudo-successful lumbar puncture due to Congenital arachnoid cyst or Tavlov cyst.
- Simple anatomical restrictions.
- Local Anaesthetic resistance.



- **Subdural Block:**

Predisposing factors:

- Difficult block- more with an epidural.
- Inexperience operator.
- Previous back surgery.
- Recent lumbar puncture.

Presenting Features:

- Variable depending upon the extent of the spread of LA.
- Slow onset (15 to 20 minutes), last up to 2 hours followed by complete recovery.
- Sparing of, or minimal effect on sympathetic and motor functions.
- Moderate to severe hypotension.
- Motor weakness: Intercostal muscles, Upper limbs.
- Progressive respiratory incoordination, apnoea.

Major Criteria: Lubenow et al

- Negative aspiration test.
- Unexpected extensive sensory block.

Minor Criteria:

- Delayed onset by 10 minutes.
- More of a sensory or motor nerve block, a variable motor block.
- Sympatholysis out of proportion to the administered dose of local anaesthetic.

### Treatment:

- Reassurance, close monitoring and cardiorespiratory support.
- Removal of the epidural catheter, avoid drugs causing bradycardia.

## • High Spinal Anaesthesia:

### Definition:

Subarachnoid block, where a higher level of motor block develops to cause cardiovascular and respiratory compromise.

### Recognition:

Tingling of Arms, shoulder weakness, difficulty in breathing, Slurred speech, Sedation, Demonstrable high block.

Table 1: A tiered approach to the identification of high spinal anaesthesia

Symptoms	Respiratory system	Cardiovascular system	Diagnosis
A weak cough, or early signs of dyspnoea	RR $\geq$ 12-15 per minute SpO <sub>2</sub> $\geq$ 95% Hypotension and no bradycardia High spinal anaesthesia is unlikely Function is at preoperative status	Hypotension, and no bradycardia	High spinal anaesthesia is unlikely
Progressive dyspnoea Weak hand grip strength (C8/T1) Can't touch nose (C5/C6) Ineffective cough	RR: 12-15 per minute SpO <sub>2</sub> $\leq$ 95% Function diminished	Hypotension, and no bradycardia	Early signs of high spinal anaesthesia
Unable to speak	Hypoventilation Hypotension + bradycardia SpO <sub>2</sub> $\leq$ 90% Function poor	Hypotension + bradycardia	High spinal anaesthesia is likely
Unable to speak	Apnoea	Hypotension + bradycardia	High spinal anaesthesia is established

### Management of High Spinal:

- Call for help and resuscitation equipment!
- 100% oxygen via a mask.
- Assess Airway, Breathing, Circulation.



- Airway + breathing compromised? or Patient unconscious: Mask ventilation/ intubation and ventilation till the effect wears off, Maintain sedation.
- Circulation compromised.
- Left lateral tilt.
- Large bore IV cannula.
- Bradycardia: Treat with atropine 500mcg (0.5mg) bolus, repeat if necessary.
- Hypotension: Rapid IV fluid infusion, Vasopressors (Mephenteramine, Ephedrine, Adrenaline): Titrate to effect.

- **Troubleshooting in Spinal Anaesthesia:**

Clinical Presentation	Possible Cause	Suggested Management
<b>No block</b>	Injection not into CSF, Syringe swap, Faulty local anaesthetic	Repeat injection (With caution), General anaesthesia
<b>Insufficient block height or density</b>	Insufficient drug delivered, Injection site too low, Anatomical abnormality	Postural manoeuvres - Head low, Intravenous analgesia/sedation
<b>Unilateral block</b>	Patient positioning, Anatomical abnormality	Postural manoeuvres: Side not blocked to be low, Proceed with care (If correct side blocked)
<b>Patchy block</b>	Insufficient drug delivered, Anatomical abnormality	Repeat injection (with caution), Intravenous analgesia/sedation, General anaesthesia
<b>Inadequate duration</b>	Insufficient drug delivered, Syringe swap, Lengthy procedure.	Intravenous analgesia/sedation, General anaesthesia

- **Other regional blocks**

- **Para cervical block:**

It is performed injecting local anaesthetics to the sub-mucosa of lateral fornices on either side of the vaginal vault. Continuous monitoring of fetal heart rate has shown that paracervical block is associated with a high incidence of foetal bradycardia as well as depressed neonates. Even intrauterine deaths have been reported. This is why this block is not so popular.

- **Pudendal nerve block**

Lower sacral roots are blocked (S2-4). 10 ml of local anaesthetic is given around each nerve at the sacrospinous ligament using a 10 cm needle passed either through transvaginal or transperineal route. It has disadvantages like incomplete analgesia, thus less used in high forceps delivery.

## \* **CONTRAINDICATIONS TO REGIONAL TECHNIQUES:**

### • **Absolute contraindications:**

#### **Patient refusal and inability to cooperate for regional block**

- Infection at the local site.
- Coagulopathy.
- Marked hypovolaemia.
- Allergy to the local anaesthetic.

### • **Relative Contraindications:**

- Pre-existing neurological disorders.
- Spine problems like backache.
- Severe heart disease.
- Heparinised patients.

Prior to the regional technique, appropriate equipment should be available, and all the resuscitation equipment should be available. The most important is that the Anaesthesiologist should be ready for failure of the block with prior preparation for general anaesthesia.

### • **Equipment, which should be ready:**

- Oxygen supply.
- Positive pressure delivery device.
- Functioning laryngoscope with different size blades.
- Suction machine with a suction catheter.
- Oral and nasal airways.
- Intravenous fluids/ephedrine/ mephentermine/atropine.
- Thiopentone.
- Succinylcholine.

The caesarean section needs a T4 or at least T6 sensory level. This is a high sympathetic block, which can cause hypotension. Preloading of patient with 1000 ml to 1500 ml bolus of Ringer lactate prior to epidural or spinal anaesthesia avoids a major hypotensive response.

Blood pressure, ECG, pulse oximetry should be monitored. Ephedrine can be given when the systolic blood pressure is less than 100 mmHg or blood pressure falls by more than 20% of baseline.

### • **Management of complications of regional anaesthesia:**

#### • **Hypotension:**

Generally, it is defined as 20 to 30% reduction in blood pressure or systolic pressure less than 100 mmHg. It is the most common side effect of regional anaesthesia. Treatment should be immediate, intravenous fluid, left lateral displacement of the uterus so that aortocaval compression is avoided. Boluses of ephedrine 5 to 15 mg or mephenteramine 3 to 6 mg boluses can counteract hypotension.

Phenylephrine, Noradrenaline can also be used with caution.

### Post-dural puncture headache:

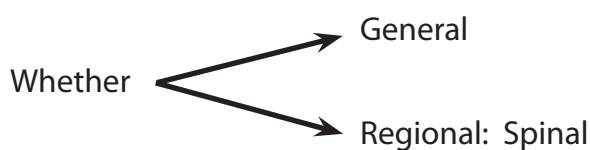
Absolute bed rest, plenty of oral fluids, IV or oral paracetamol, caffeine tablets, and lastly epidural blood patch. If Caffeine tablets are not available, then the patient should be encouraged to take coffee.

### \* GENERAL ANAESTHESIA:

General anaesthesia techniques for emergency obstetric caesarean section. Common indications for emergency surgery in obstetrics are:

- Foetal distress.
- Umbilical cord prolapse.
- Maternal haemorrhage.
- Amnionitis.
- Genital herpes with rupture of membranes.
- Dystocia.
- Abnormal foetopelvic relation.
- Transverse lie.
- Breech presentation.
- Labour unsafe to mother and foetus.
- Previous classic caesarean section.
- Previous large uterine surgery or large myomectomy surgery.
- Central or partial placenta previa.
- Abruptio placentae.
- Vaginal reconstruction.

### • What to choose?



It depends on multiple factors:

- Urgency of operation
- Patient preferences.
- The skill of the Anaesthesiologist.
- Associated diseases affecting pregnancy.
- Anticipated difficulty in airway management.
- Presence of contraindications to regional anaesthesia.

Cesarean section rates have been steadily increasing in recent years (25%) of all deliveries.

- **Advantages of regional anaesthesia:**

- Less neonatal exposure to the potential depressant drug.
- Less chance of maternal pulmonary aspiration.
- Awake mother and child after delivery.
- Early ambulation.
- Avoidance of difficult airway and airway trauma-related complications.

Epidural anaesthesia is preferred over spinal in more cardiac compromised patient because it affects hemodynamic slowly, allowing more reaction time.

- **Advantages of general anaesthesia:**

- A very rapid and reliable onset.
- Control over airway and ventilation.
- Potentially less hypotension than regional.
- No danger of neuro deficits.
- No PDPH.

As it is well known by now, parturient are high-risk cases in comparison to other general anaesthesia procedures. All the equipment, anaesthesia machine and drugs should be ready and checked prior to starting of general anaesthesia.

- i. **Things to remember before starting general anaesthesia:**

**Pre-oxygenation:**

Why is it needed?

We know from physiological changes; pregnant mothers have less oxygen reserve because; they have low functional residual capacity. They have a high metabolic rate needing more oxygen per minute. Pre-oxygenation prevents rapid desaturation of the pregnant mother. Therefore, the Anaesthesiologist not only gets some more time for difficult intubation but it also avoids hypoxia-related complications, if due to some reason the end tracheal intubation is delayed or difficult.

**Method**

**How is preoxygenation performed?**

The patient should be supine with left lateral tilt and comfortable on the operation theatre table. 100% oxygen at a flow rate of 6 to 8 litres/minute is administered using a tight-fitting facemask connected to a circuit with a fully open expiratory valve. The parturient is allowed to breathe spontaneously.

This procedure is done for at least 4 to 5 minutes, which has been found to be the time required to completely refill the lungs with oxygen. After completion of 5 minutes, induction by an intravenous method is started.

- ii. **Induction and rapid sequence intubation:**

The intravenous route is the method of choice for induction in the pregnant woman.

**Drugs used:**

- Thiopentone Sodium.
- Propofol.
- Ketamine.

Thiopentone Sodium is the most commonly used drug. Dose: 4 to 5 mg/kg. The drug is used as a 2.5% solution with pre-calculated doses, which is kept ready in a syringe prior to starting of induction.

- Propofol dose: 2 mg/kg.
- Ketamine dose: 1-2mg/kg.

#### Muscle relaxant:

The drug of choice is Succinylcholine.

Recently, a newer drug has been introduced for rapid sequence intubation (Rocuronium)

Doses: Succinylcholine 1.5 mg/kg to 2 mg/kg

Rocuronium 0.6 mg/kg to 1 mg/kg

(However, it needs to be remembered that Rocuronium is a long-acting agent and in case of unanticipated can't ventilate, can't intubate situation, the patient will remain paralysed for a long period of time and may result in catastrophe)

The onset of action for both these drugs is around 60 seconds.

After initiation of the intravenous line and connecting the patient to monitor, ECG, pulse oximetry, blood pressure, and capnography should be monitored prior to induction of anaesthesia.

#### Steps of induction:

After adequate preoxygenation, a pre-calculated dose of Thiopentone sodium is administered intravenously. Apply cricoid pressure as consciousness is being lost.

- Administration of Succinylcholine intravenously.
- Do not ventilate during this period.
- Wait for 60 seconds after giving the relaxant.
- Laryngoscopy and intubation are performed.
- Inflation of endotracheal tube cuff.
- Confirmation of Endotracheal intubation
- Allow the surgeon to start the surgery after the circuit is connected and endotracheal tube cuff is inflated.

#### Maintenance:

General anaesthesia is maintained with oxygen and nitrous oxide in a mixture of 50%:50%.

Along with this mixture inhalation anaesthetic, halothane 0.5% or Isoflurane 0.75% can be given. Continue monitoring of ECG, blood pressure, pulse oximetry and capnography.

Administer opioids and oxytocin after delivery of the baby.

#### General anaesthesia for emergency caesarean section:

## Incidence of complication

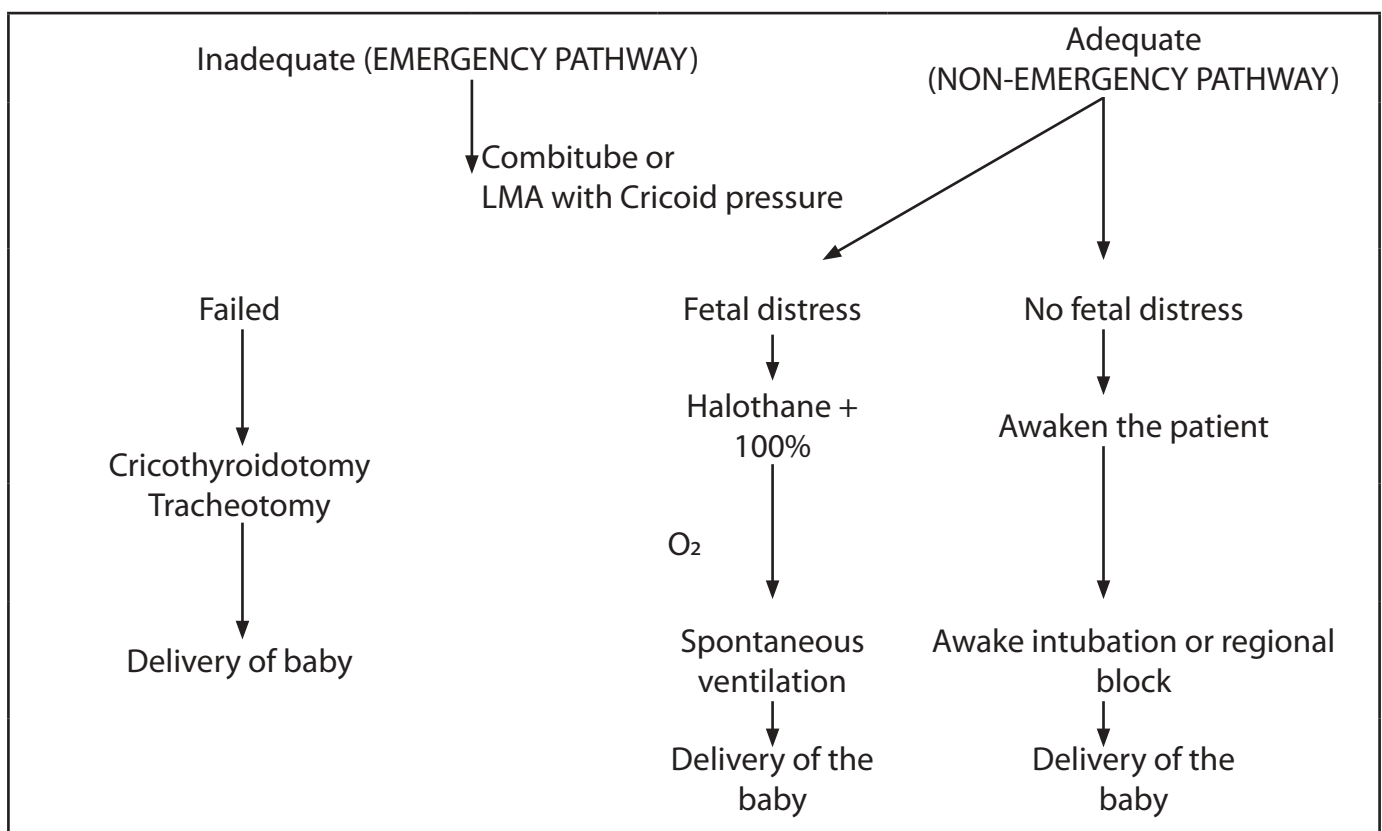
Aspiration 1:400

Failed intubation 1:300

An anesthesiologist should remember this value always because, in comparison to other surgery, the incidence of aspiration and failed intubation is very high. It is 1:2000 in the nonpregnant.

In view of a high incidence of aspiration and failed intubation it is always preferable to administer non-particulate antacid like 30 ml of 0.3 M sodium citrate 30 to 45 min prior to induction of general anaesthesia, especially to those who have taken food recently. Ranitidine and Metoclorpromide are the drugs, which are commonly used prior to induction of general anaesthesia because ranitidine, being an H-2 blocker, serves to reduce the gastric acid production, and Metoclorpromide hastens gastric emptying.

Examination of the Airway should be done very carefully, as described in the module for difficult airway management.



One must remember that the mother's life takes priority over life of the fetus.

### The technique of GA for cesarean section:

- The patient is placed in the supine position with a wedge under right hip for left uterine displacement.
- Pre-oxygenation with 100% O<sub>2</sub> for 3 to 5 min
- The patient is draped and prepared for surgery
- When the surgeon is ready, rapid sequence induction and intubation with cricoid pressure is performed. Thiopentone sodium 4 - 5 mg/kg and Succinylcholine 2 mg/kg is given in a pre-calculated dosing method.
- The surgery begins only after intubation is successful and complete

- Anaesthesia is maintained with 50% O<sub>2</sub>; 50% N<sub>2</sub>O and Volatile agents 0.5% halothane, 0.75% isoflurane.
- Non-depolarizing agent for muscle relaxation, Vecuronium, 0.05 mg/kg, Rocuronium 0.3 Mg/kg, Atracurium 0.25 mg/kg
- After delivery of the foetus 10-20 units of oxytocin is given intravenously in each litre of balanced salt solution.
- Opioids should be given ideally after delivery of the baby.
- After completion of the surgery, residual neuromuscular blockade is reversed with Neostigmine (40-50 µg/kg) + glycopyrrolate (7-10µg/kg).
- Patient's trachea should be extubated when she is fully awake, and vitals are stable.

### \* ANAESTHESIA FOR LABOUR AND VAGINAL DELIVERY:

Pain during the first stage of labour results from uterine contractions and cervical dilatation. It is usually confined to T11-12 dermatomes during the initial phase but eventually involved the T10-L4 dermatomes as the labour enters the active phase. Similarly, pain in the second stage is conveyed by the Pudendal nerve (S2- 4).

#### i. Drugs that can be used for vaginal delivery:

All opioids cross the placenta, so it has a depressive effect on the fetus as well. If the foetus is premature, these effects are aggravated.

**Fentanyl:** Fentanyl 50-100µg has also been used with good effect. Administration of opioids should always be carried out after having a discussion with obstetricians knowing the duration left for delivery.

**Pethidine:** It is only given when the delivery is expected 4-5 hours after or within one hour of giving the drugs. The duration of action of pethidine is 1-3 hrs.

**Morphine:** should be avoided because, with equianalgesic dose, it causes more respiratory depression than pethidine and fentanyl in patient delivering vaginally.

Concerns of neonatal respiratory depression should be discussed, and the neonatologist should be informed about it. Availability of Naloxone and equipments for assisted neonatal ventilation should be ensured.

### POSTOPERATIVE CARE AND MANAGEMENT:

#### \* Postoperative Care: General Considerations:

Recovery from anaesthesia can range from completely uncomplicated or life-threatening. With due & diligent care and proper vigilance, however, mostly it is safe & smooth.

Irrespective of G/A or S/A, the patient should be monitored in the postoperative period for the level of consciousness, activity, and vital signs-viz. pulse, respiration, NIBP, SpO<sub>2</sub>, ECG etc. till the patient is:

1. Easily arousable
2. Fully oriented
3. Able to maintain & protect the Airway



4. Has stable vital signs for at least 15-30 min
5. No obvious surgical complications, e.g. Active bleeding.

Controlling Postoperative pain, Postoperative nausea and vomiting (PONV) and shivering are also highly desirable.

Besides patients receiving spinal anaesthesia should also show signs of resolution of both sensory & motor blockade. Objectively, Post anaesthetic Aldrete recovery score is a good guide and help to decide acceptable recovery from general anaesthesia- a score of 9-10 is accepted for discharge to the ward.

Aldrete Score				
Activity	Respiration	Circulation	Consciousness	Oxygen Saturation
2: Moves all extremities voluntarily on command	2: Breaths deeply and coughs freely.	2: BP +20 mm of preanesthetic level	2: Fully awake	2: SpO <sub>2</sub> > 92% on room air
1: Moves 2 extremities	1: Dyspneic, shallow or limited breathing	1: BP + 20-50 mm of preanesthetic level	1: Arousable on calling	1: Supplemental O <sub>2</sub> required to maintain SpO <sub>2</sub> >90%
0: Unable to move extremities	0: Apneic	0: BP +50 mm of preanesthetic level	0: Not responding	0: SpO <sub>2</sub> <92% with O <sub>2</sub> supplementation

After spinal anaesthesia, the following points/tasks is to be kept in mind:

1. Pulse, Respiration & BP should be monitored carefully every 5-15 min.
2. Treat hypotension, bradycardia, if any
3. Oxygen administration (30-40% by mask/nasal cannula) if SpO<sub>2</sub> is low and patient heavily sedated.
4. Bladder catheterisation, if urinary retention happens

After general anaesthesia, the following points/tasks should be kept in mind:

1. Recovery in a lateral or head-up position. Head down.

2. Oropharyngeal Airway may be needed to restore airway.
3. Oxygen administration.
4. Monitoring of Pulse, Respiration, & BP every 5-15 min.
5. Facilities for suction, reintubation & oxygenation should be ready at hand.
6. Pain Relief: This should be taken care of properly to avoid restlessness & often postoperative hypertension. (Details are given earlier).
7. Postoperative nausea and vomiting: Postoperative nausea & vomiting is a very common problem following GA- occur in 20-30% cases. The cause is usually multifactorial –anaesthetic agents, type of procedure & patient factors. Also, nausea is a common complaint reported at the onset of hypotension after spinal anaesthesia (blood pressure fluctuations and bradycardia due to increased vagal tone commonly precedes or coincides with emesis).
8. 5HT-3 antagonist (Ondansetron 4 mg IV) or prokinetic agents (Domperidone/ Metoclopramide) can be used as a prophylactic measure or treatment for PONV. In refractory cases, dexamethasone, 0.15-0.2 mg/kg (4-10 mg) may be combined with another antiemetic. Shivering & Hypothermia: occurs postoperatively due to intraoperative hypothermia or the effects of anaesthetic agents. It is also common in the immediate postpartum period. It is due mostly to redistribution of heat from the body core to the peripheral compartments. Intense shivering causes a precipitous rise in O<sub>2</sub> demand, CO<sub>2</sub> production and cardiac output. It is to be treated with Warming devices- heater/blower, blankets etc. Often small doses of Meperidine (10-50 mg) or Tramadol (25-50 mg) iv dramatically reduces /stops shivering.
9. Hypoxia: quite commonly encountered. Due mostly to hypovolaemia or hypoventilation. Mild cases simply respond to O<sub>2</sub> administration by mask (30-40%). Opioids antagonist (naloxone) may be needed to cancel narcotic respiratory depression. Severe & resistant cases should be given 100% O<sub>2</sub> by mask or ETT until the cause is established and other therapy instituted.
10. Hypotension: usually due to decreased venous return, left ventricular dysfunction, or to excessive arterial vasodilatation - Hypovolaemia being by far the most common cause.

**\* Postoperative complications of general Anaesthesia and its management:**

• Common complications after general anaesthesia:

1. Nausea.
2. Vomiting.
3. Hypoxia.
4. Hypertension.
5. Bradycardia.
6. Incomplete Recovery.
7. Headache.
8. Restlessness.
9. Shivering.
10. Drug toxicity.
11. Cyanosis.
12. Hypothermia.
13. Retention of Urine.

- **Management of Postoperative Complications:**

**Treat the cause:**

What you should look for in the postoperative recovery area after general anaesthesia:

- Level of consciousness.
- Pulse.
- Blood pressure.
- Respiration.
- Urine Output.
- Colour.
- Pain.
- Treat according to the symptoms for these symptoms.

**Analgesic Drugs:**

- **Diclofenac:**

I/M / IV /suppository/ patch

Dose: I/M / IV – 75 mg. BD.

Suppository – 100mg. BD.

Patch: - 100 mg. BD or 200mg. OD.

(To be avoided in case of Renal disease and patient with H/O chronic gastritis).

- **Paracetamol:**

IV 1 gm. 6 hourly. Maximum of 4 gm. in 24 hrs. in adult. (to be avoided in case of liver disease).

- **Tramadol:**

IV 1-2 mg /kg 6-8 hourly

(To be avoided in case of seizure disorder and absolute contraindications: patient with h/o serotonin syndrome. Relative C/I: liver and renal failure; seizure disorder; concurrent treatment with antidepressants (e.g., SSRI, SNRI), patients on warfarin).

**IMPORTANT POINT:**

- To obtain more effective analgesia, combine two / three drugs, e.g. diclofenac 75 mg I.M./I.V. BD or suppository/patch 100 mg BD with injectable paracetamol 1 g IV 6-hourly and/or injection Tramadol 75 mg IV 6-8 hourly and/or bupivacaine skin infiltration with 0.25%.
- To take care of Postoperative nausea and vomiting also add ondansetron 0.1 mg/kg IV twice a day.

**KEY POINTS TO REMEMBER:**

- Acid Prophylaxis to be given to all patients irrespective of General Anaesthesia or Regional Anaesthesia
- Regional anaesthesia/analgesia is the most reliable and effective method to provide pain relief to the patient.
- An intravenous line is a lifeline

- Every epidural dose of local anaesthetic should be considered a test dose and should be given in small parts.
- Remember that equipment for general anaesthesia should always be checked and ready, even while administering regional anaesthesia.
- Preloading of patient with 1 to 1.5 litre of Ringer's lactate before epidural or spinal anaesthesia avoids a major hypotensive response.
- The patient should be pre-oxygenated prior to induction of anaesthesia using 100% oxygen at a flow rate of 6-8 litre/minute for at least 4-5 minutes.
- Rapid sequence induction using Succinylcholine is the technique of choice in pregnancy.
- One must be thorough with the failed intubation drill.
- Regional anaesthesia is always the technique of choice for an emergency caesarean section at the FRU.
- Reconfirm drug name, basicity and expiry date of the drug before injecting into the subarachnoid space.

### CHECK YOUR PROGRESS:

- Commonest size endotracheal tube used for obstetric anaesthesia?
  - 6.5
  - 7.5
  - 8.0
  - 8.5
  
- Amount of Halothane that can be used safely in a normotensive parturient after induction?
  - 1.0%
  - 0.5%
  - 1.5%
  - 2%
  
- Intubation is difficult in an obstetric patient in comparison to other patients because?
  - airway is oedematous.
  - Oedematous tongue.
  - Enlarge breast.
  - All of the above.
  - None of the above.
  
- Preoxygenation is a very important step in parturient because?
  - Low FRC.
  - High O<sub>2</sub> consumption.
  - Difficult intubation.

- d. All the above.
  - e. None of the above.
- v. Size of the LMA which can be mostly used for Indian mothers?
- a. 2-3
  - b. 3-4
  - c. 4-5
  - d. None of the above
- vi. Intravenous opioids analgesia is obtained in pregnant mother before delivery of baby undergoing general anaesthesia?
- a. It causes maternal respiratory depression
  - b. It causes foetal respiratory depression
  - c. It does not act at all
  - d. Very high dose is required
- vii. In a failed intubation situation the first thing which is needed most is?
- a. Try the intubation again and again
  - b. Call for help
  - c. Try surgical airway
  - d. Defer the operation
- viii. Why are pregnant mothers more prone to aspiration?
- a. High intragastric pressure
  - b. High acidity because of placental secretion
  - c. Low gastric motility
  - d. All of the above
  - e. None of the above
- ix. In a pre-eclamptic parturient, the method of anaesthesia intervention for elective LSCS is?
- a. Spinal anaesthesia
  - b. General anaesthesia
  - c. Both
  - d. None
- x. Most common complication of spinal and epidural anaesthesia is?
- a. Aspiration
  - b. Hypotension
  - c. Vomiting
  - d. Fetal distress

- xi. In present-day obstetric practise which of the following drugs does not have any role?
- Bupivacaine
  - Thiopentone sodium
  - Pethidine
  - Diazepam
- xii. What are the confirmatory signs of intubation?
- Under vision putting of ET tube
  - ET CO<sub>2</sub>
  - Chest expansion
  - Confirmation of air entry by stethoscope
- xiii. What is the most important step in getting the spinal/epidural block?
- Proper position of patient
  - Proper needle quality
  - Proper preloading
  - Availability of proper staff
- xiv. In foetal distress with severe bradycardia method of anaesthesia should be:
- General anaesthesia
  - Spinal anaesthesia
  - None
  - All of the above
- xv. Definitive treatment of PDPH is
- Plenty of oral fluids
  - Caffeine tablet
  - Epidural blood patch
  - Supine position
- xvi. The most cost-effective way of giving anaesthesia to a parturient is
- Spinal
  - Epidural
  - GA
  - Combined Spinal Epidural Anaesthesia
- xvii. Arrhythmia just after intubation is best treated with
- Lidocaine
  - Amiodarone

- c. Sotalol
- d. Propranolol

xviii. Intubation is best performed in

- a. Head down position
- b. Sniffing position
- c. Lateral position
- d. Supine position

xix. Intravenous opioids are best given

- a. Just before delivery of baby
- b. Immediately after delivery of baby
- c. At the time of intubation
- d. At the time of extubation

xx. Oxytocic is given

- a. Just before delivery of baby
- b. Immediately after delivery of baby
- c. At the time of intubation
- d. At the time of extubation

#### Further Findings:

- Anaesthesia – Miller.
- Clinical anaesthesia – Barash.
- Obstetric anaesthesia – Chestnut.





# Week 5 - Module

## Anesthesia Machine, Monitoring



# 16

## Anaesthesia machine

### INTRODUCTION:

During anaesthetic administration, Anaesthesiologists create an artificial atmosphere where patient's protective reflexes are suppressed/abolished by your technique. The patient is exposed to internal and external threats therefrom. So, this is our duty and responsibility to guarantee:

- An adequate oxygen concentration that will prevent hypoxia to the patient,
- Satisfactory elimination of carbon-dioxide, and
- Avoidance of accidental administration of excessive anaesthetic concentration.

For a safe conduct of anaesthesia it is important to know the working principles of the anaesthesia machine and be able to detect faults if and when they occur. So, familiarity with the anaesthesia equipment is very important before anyone starts using these. The Module on machine has been divided into three chapters for ease of reading and classification. The whole module has the following objectives.

### OBJECTIVES:

After going through this module one should be able to describe the:

Learning Objective	Knowledge	Skills
History of Anaesthesia Machine	✓	
Basic concepts of physics relevant to Anaesthesia Machine	✓	
High , intermediate and Low pressure systems – medical gases and Anaesthesia machine	✓	
High pressure System Medical Gas Cylinder (especially important Oxygen) Manifold Safety and Storage	✓	✓
Intermediate pressure system – the pipelines and the Hoses	✓	

Low pressure system – The Anaesthesia machine Components, flow of the gases, safety features, anti – hypoxia devices, breathing systems	✓	✓
Breathing systems Open circuits and Closed Circuits	✓	✓
Anaesthesia Machine safety features	✓	✓
Anaesthesia Machine Checking	✓	✓

### KEY LEARNING POINTS

- Anaesthesia Machine understanding is very important to perform a safe anaesthetic
- The basic concept of the Anaesthesia machine including gases cylinder mounted on it or supplied through the pipelines from central gas stores is to provide medical gases with or without inhalational agents at safe pressure and designated flow to the patient through either open or closed circuit breathing system. Thus the Anaesthesia machine helps the Anaesthesiologists to assist the patients breathing with appropriate gases without causing harm to the patient and healthcare workers.
- The Gas supply from the Source till patient can be classified on the basis of its pressure as High, intermediate or low pressure system.
- Though the Anaesthesia machine has seen a tremendous change from the Basic Boyle’s machine to modern day workstations, the essential concept and the components remains more or less same as follows with safety mechanisms employed at all stages.
  - A high pressure supply of medical gases (Cylinders or central pipeline)
  - Pressure Gauges on the cylinders as well as pressure reducing Valves which changes the pressure to low pressure flow
  - Flow meters for Gases (Manual or electronic)
  - Vaporisers for carrying inhalational agents in measured concentrations to the patients
  - Anaesthesia breathing system (Open or closed) to help patient breath as well as deliver the medical gases

### COMPONENTS:

Understanding an anaesthesia machine will be easier if the gas flow is traced from its source, through the machine, to the patient. The following components are likely to be encountered in sequence:

- Source of gas supply.
- Yoke assembly.
- Pressure gauge.
- Pressure regulators.

- Oxygen pressure failure safety/warning devices.
- Flow meters.
- Oxygen ratio control devices.
- Vaporizers.
- Common gas outlet.
- Anaesthesia breathing systems.

We will discuss individual components briefly in the following pages to give a comprehensive view of the whole machine. Before that lets have a look at brief history of Anaesthesia machine.

## HISTORY OF ANAESTHESIA MACHINE

- When WTG Morton demonstrated Ether Anaesthesia at MCG, Boston in 1846 he did not require a fully developed anaesthesia machine.
- The 'path changing' invention was the process of storing the oxygen and nitrous oxide as compressed gases in steel cylinders in the 19<sup>th</sup> Century.
- But natural, when cylinders became available, there was a perceived need for an instrument on which they could be mounted as well as through which they could be given safely.
- Henry Edmund Gaskin's Boyle in 1917 modified the Gwathmey Apparatus of 1912 and this became the commonly known Boyle's machine. This was first made by Coxeter and Son on advise of Lord George Wellesley which was then later acquired by the British Oxygen Company (BOC). BOC kept the trade name of Boyle's Machine to pay respect to Sir Boyle.
- It is important to note that two other Anaesthesiologists were already using the concept before 1917 for delivering anaesthesia – i.e. Gwathmey Apparatus in 1912 and Sir Marshall during first world war.
- Furthermore, development continued to take place. Few examples ....
 

Circle Absorption system – 1930	Dry Bobbin flowmeters – 1933
Pin Index safety system – 1952	Bodok Seal – 1958

## OXYGEN GAS, CYLINDER AND PIPED GAS SYSTEMS

### Cylinders

- Medical Gases are supplied to the Anaesthesia machine either through the pipelines (which eventually will take gases from cylinders or liquid oxygen plants or oxygen concentrator generator plant) or through the cylinders directly mounted on the back of Anaesthesia machine.
- The Anaesthetic gases are supplied in seamless cylinders made of molybdenum steel, an alloy, which allows the cylinders to be made thinner and lighter. As compared to older times when these used to come in hand-forged steel, the present cylinders can hold almost three times more gas whereas weighing significantly less allowing ease of portability.
- Oxygen, nitrogen and air are stored as compressed gases. These gases do not liquefy at the pressures to which they are filled at 20°C since their critical temperature is low.
- The quantity of gas inside the cylinder can easily be estimated using a pressure gauge, as the quantity is directly proportional to the gauge pressure. In clinical practice, changes in ambient temperature do not affect the pressure significantly.
- Nitrous oxide (N<sub>2</sub>O) and carbon dioxide (CO<sub>2</sub>) liquefy at pressures to which the cylinders are filled



at 20C and are therefore stored as liquids.

- The cylinders are not filled completely but only up to a filling ratio. Filling ratio = Weight of liquid with which it is filled/weight of the water it can hold. The filling ratio for N<sub>2</sub>O and CO<sub>2</sub> is 0.67 in the tropics.
- The contents of these cylinders can be accurately measured by weighing these cylinders rather than by using a pressure gauge. The pressure gauge will only measure the pressure of the gas (vapour) above the liquid level, which will remain constant till all the liquid is converted into (vapour) gas. Thus, the gauge cannot reflect the quantity of gas in the cylinder. If the environmental temperature is above the critical temperature of the gas, then the cylinder contents will be fully in gaseous state and the pressure gauge will reflect the quantity of the contents. While using a cylinder of N<sub>2</sub>O with a continuous flow, the cylinder pressure tends to fall mainly due to cooling of the liquid as it vaporizes and the consequent fall in vapor pressure. If the flow is interrupted for a brief period, the gauge will again read full.

### Parts of the Cylinder:

- Broadly the cylinder can be divided into following parts
  - Body, shoulder and Neck of the cylinder
  - Valves fitted on the cylinder
- The body, shoulder and the neck of the cylinder as noted are made up from seamless material (preferably molybdenum steel, aluminium or a composite)
- The body and shoulder has colour coding which is according to accepted national laws for specific gases. The shoulder also has markings on the cylinder about its details.
- The neck of the cylinder has screwed tapering into which the Valve fits through which gases can flow out
- There are variable types of valves available for the cylinders which depends upon its size mainly. The common available types of valves fitted into the cylinder can be classified as
  - Non Integral valves (these will need additional external pressure regulator)
    - Pin index outlet valves
    - Bull Nose Outlet Valves
    - Hand wheel actuated Valves
  - Integral Valves (They have a built in pressure regulator and many a times also the flowmeters to allow gases to be flowed).
- The medical gas cylinders that can be fixed to the anaesthesia machine are provided with a flush type valve. The valve has got a tapered screw thread to fit the cylinder, pin index holes, spindle, and gland with a gland nut and an outlet. When the valve is screwed to the cylinder, a fusible material is used to seal the leak between the valve and the cylinder. This material will melt and prevent the risk of an explosion in the event of fire. Occasionally, there is a leak around the spindle of the valve. This can be prevented by gently screwing down the glandnut.
- The Valves are the most delicate part on the cylinder. The gases are allowed to come out through here by turning them on or off as well as these help in refilling the cylinders.
- The cylinder also contains pressure relief device which has aim to vent the gases inside the cylinder to atmosphere in an unforeseen event of overfilling or increased pressures inside due to other reasons.

### Conical Depression:

On small cylinders which can be attached to the anaesthesia machine, there is a conical depression present which will receive the retaining screw of the yolk assembly of the anaesthesia machine.

- There may be chances that wrong gases may be attached to the wrong cylinder and therefore as a safety mechanism to prevent this, some safety mechanisms are built in. For e.g. Pin Index system on Small Cylinders which are attached on the back of anaesthesia machine.

### Pin index system:

(Figure 1 and Table 1)

- The pin index system is used in small cylinders, which fit directly on to the anaesthesia machine.
- The cylinder has a flush type valve and the machine has a yoke to accept the valve.
- The pin index consists of two pins projecting from the inner surface of the yoke and two corresponding holes in the cylinder valve. There are seven hole positions on the circumference of a circle of 9/16-inch radius centred in the port.
- The pins are 4 mm in diameter and 6 mm long. Two pins are assigned for each gas, one on either side of the mid-line (table 1). This prevents fixing a wrong gas cylinder into the yoke assembly.

**Table 1 Pin index system & Colour Coding for Cylinders**

Gas	Index Pins	Colour Coding	
		Body	Shoulder
Air	1-5	Black	White & black
Oxygen	2-5	Black	White
Nitrous oxide	3-5	Blue	Blue

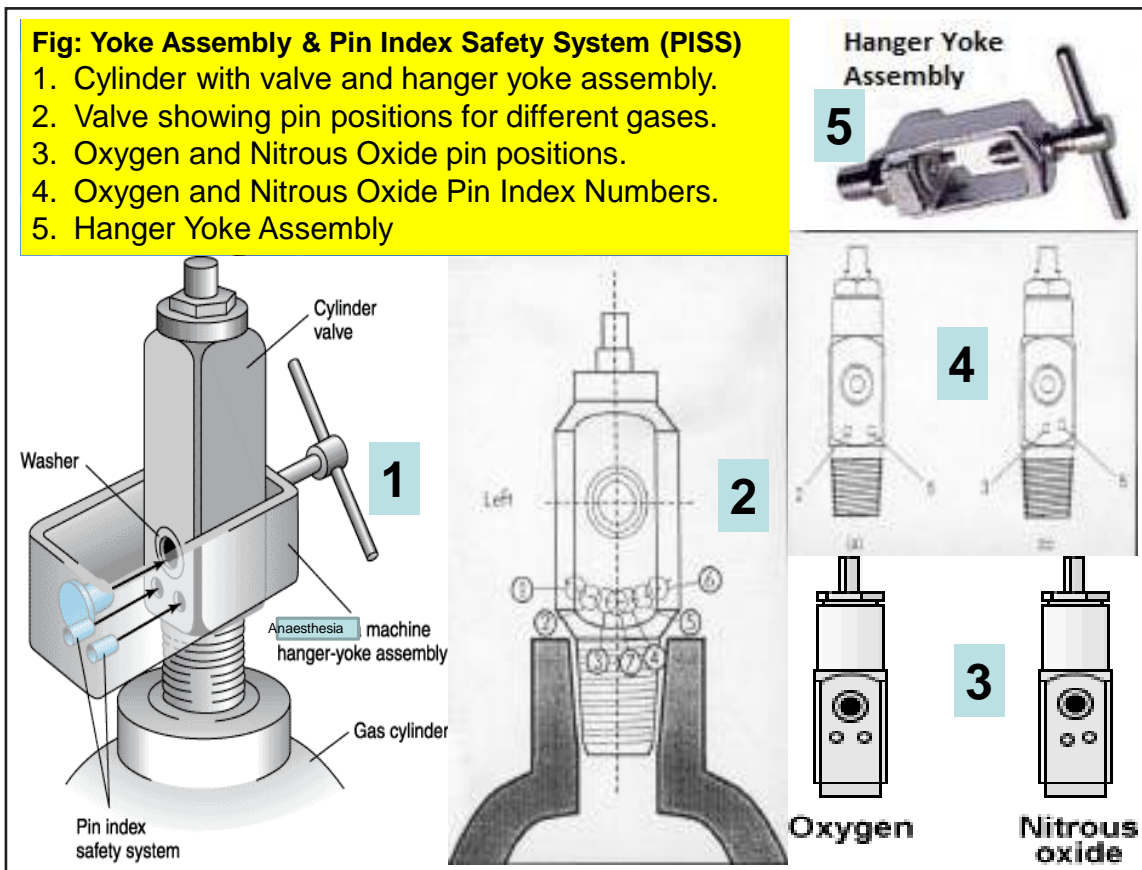
- Until the pin and holes match with each other, the cylinder cannot be mounted on the back of the anaesthesia machine.  
(Figure 1 – Pin Index and yoke assembly)

### Yoke assembly:

(Figure 1)

The hanger yoke assembly supports the cylinder and connects it to the machine. It has:

1. a body, which is the frame work and the supporting structure,
2. the retaining screw, that tightens the cylinder in the yoke,
3. the index pins, that prevent connection of a wrong cylinder,
4. a gas seal (Bodok seal) to prevent a leak between the cylinder and the yoke,
5. a filter, that removes dirt from the gas and
6. the check valve assembly that ensures unidirectional flow.



- When a cylinder is fitted to the machine, care should be taken to see that the sealing washer (Bodok seal) is present and is in good order to prevent leak between the cylinder and yoke.
- It is dangerous to use more than one washer because it can override the pin index system and allow fixation of a wrong cylinder.
- Also, before fixing the cylinder, the outlet of the valve should be cleared of oil and dust by slowly opening the cylinder and letting out some gas. This is known as 'cracking the cylinder'.
- After fitting, the cylinder should always be opened slowly to release the pressure gradually. Sudden opening can produce a shock wave in the pressure gauge and regulator and damage the parts.

#### Cylinder size:

- Technically cylinder sizes as described above are defined by their water holding capacity. These can vary from as small as 1.2 litres to as high as close to 45 litres.
- They are given Alphabetical names from A to J , generally the progressive letter indicating increased cylinder size over the previous ones.
- Size E cylinder is commonly used on the Anaesthesia machine and Cylinder H or J used in cylinder manifold central gas pipeline system.



Table 2: Oxygen common cylinder sizes and detail:

Oxygen Cylinder Size	B	E	H
Pressure	1900 psi	1900 Psi	2200
Content in litres of gas	200 Litres	660 Litres	6900 litres

Table 3: Nitrous oxide common cylinder sizes and details:

Nitrous Oxide Cylinder Size	C	E	J
Pressure	745 psi	745 psi	745 psi
Content in litres of gas	450 litres	1800 litres	18000 litres

(Note that for Nitrous oxide it's the same pressure in all cylinders)

#### Colour coding, cylinder testing and marking on Cylinder:

- Medical gas cylinders are colour coded and the name of the gas is also written on the neck of the cylinder.
- An international colour coding standard validated system is used in India (though many countries use their own colour coding system creating confusion).
- The Colour coding and pin index system for the Cylinder identification are mentioned in table 1 above.
- The cylinders are hydraulically tested every 5 years and the year and quarter of testing is recorded by a mark on the neck of the cylinder and valve block.

The testing performed on the cylinder at various intervals are:

- Hydraulic test
- Bend test
- Tensile test
- Impact test
- There are labels on the cylinders which will help identify the cylinder content, its condition, hazards, and other miscellaneous information.
  - Chemical symbol of the gas content along with its name
  - Product specification
  - Diamond shaped hazard warning
  - Manufacturers details
  - Batch number
  - Date of refilling, contents in litres
  - Empty cylinder weight
  - Directions for use

## Storage of Cylinders & Use

- Cool, dry and adequate ventilated area.
- Clean area, constructed of fire resistant material.
- Good access for vehicle delivery of the cylinders.
- Lock and secured facility.
- No direct sunlight.
- Cylinders should have separate areas for full and empty cylinder.
- No smoking zone / No flame zone.
- Cylinders should be stored upright and chained to prevent falls or accidents.
- Always check the label, name and marking on cylinder.
- "Crack" the cylinder before connecting to yoke to blow dust away.
- Check the cylinder Pin index system, Bodok seal on Yolk assembly.
- Open Valve slowly.
- Always support the cylinder with foot while fitting at the back of machine and not allow it to fall.

## Hazards associated with cylinder

(Though rare especially with adequate handling, one should be aware of the hazards)

- Wrong cylinder fitted in faulty or broken pin-index system.
- Damaged Valve.
- Wrong labelling or refilling of cylinders.
- Mechanical accidents.
- Fire hazards.

## Piped medical gases and vacuum systems:

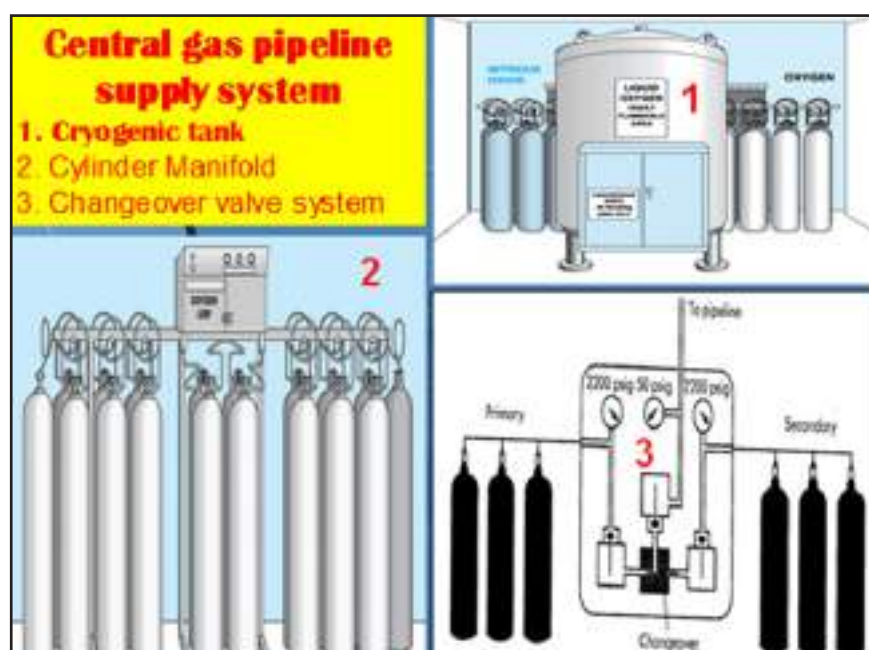


Figure 2 : piped medical gases

- Piped medical gases and vacuum systems are used in bigger institutions in India. Generally, the Cylinders act of source of oxygen in many places though other alternative of feeding the oxygen into the hospital gas pipelines are oxygen concentrator plants or liquid oxygen plants.
- These systems allow bulk storage of gases in one place and deliver at a constant working pressure through fixed pipelines to the place of utility, using terminal outlets.
- The Cylinder manifold is the main source of supply in many institutions.
- A manifold design consists of two equal banks of gas cylinders with centrally located control panel which will allow provision of gas automatically through one of the banks at a constant pressure of around 4 bar into the pipeline system.
- The large cylinders are mostly divided into primary bank and secondary bank (also known as standby bank)
- The cylinders are connected to the common pipeline through non return valve and this in turn is further connected to the pipeline through pressure regulators to make the high pressure gas in the cylinders to intermediate flow system.
- This pipeline made up of copper material are colour coded and pass through the hospital facility (with necessary lock down system for a given geographical area through flow valves) ending in terminal outlets at the facility like operation theatres and ICU beds.
- The terminal outlets are of the Schrader quick coupler type.
- Each quick coupler consists of a pair of non-threading gas specific male and female components. A releasable spring mechanism locks the components together.
- The probes (male component) fixed to one end of the flexible pipeline (hose) carry an index collar and the outlets (female component) a groove to accept the collar.
- Fixation into an incorrect outlet is thus prevented by the use of index collars.
- The wall outlet and the connectors for the flexible pipeline should be from the same manufacturer.
- The other end of the flexible pipeline is attached to a yoke block with a pin index.
- Several accidents have been caused by the connection of the probe for one gas at one end and the yoke block for another gas at the other end of the flexible pipeline.
- Nearly all these accidents have been caused by the alterations or faulty repairs carried out by incompetent or unauthorized people. To prevent these accidents, the flexible pipelines are also colour coded now and should be serviced by authorized people.
- The present standard is to fix the flexible pipeline directly to the machine at the special inlet points meant for them using diameter indexed safety system (DISS) screws.

See figures below:



Figure 3 – Terminal wall outlets from medical gas pipelines at point of use



Figure 4 – Schrader probes for different gases from flexible hose pipelines (Connected to the terminal wall outlets)



Figure 5 & 6: Non interchangeable screw threaded system for various gases (These other end of flexible hose are connected on anaesthesia machine)

## ANAESTHESIA MACHINE

- The Anaesthesia machine have evolved over a period of time from a basic Boyle's machine to the newer advanced workstations especially in terms of precision, safety and user comfort, however, the basic design and concept remains similar pretty much.
- Pressurised gas supplied through the cylinder mounted on the machine or through pipelines is converted to low constant pressure by the anaesthesia machine and is then passed through the flow meters through the inhalational agents vaporisers (Optional) and through breathing system (either open or closed circuits) to the patient through a series of safety mechanisms.
- The basic Boyle's machine has 5 important elements as follows, especially, when considering the direction of gas flows from source of gas to patient (These are essentially present in the newer anaesthesia workstations also with added new features)
  - A high (Cylinders) or intermediate (Pipelines) pressure supply of gas
  - Pressure gauges on oxygen cylinders with pressure reducing valves to decrease the above pressure into low pressure system to be delivered to the patient (oxygen flush delivers gas at intermediate pressure)
  - Flow meters
  - Inhalational agent vaporisers
  - Breathing circuits / systems
- Looking at the above description, the anaesthesia machine can be easily divided into three parts based on the pressure of gases it receives or deals with.

### High Pressure System

- Gas in the cylinders is high pressure (though not exactly part of machine).
- Hanger Yoke (Connects the cylinders to the machine).
- Yoke block.
- Cylinder pressure gauge on yoke assembly which will indicate the pressure in attached cylinder.
- The pressure regulator downstream of the yolk assembly which will connect the high pressure variable gas into a constant low pressure gas which is suitable for the machine as well as for patient use.

### Intermediate pressure system

(generally pressure of around 35 to 55 psig or 4bars).

- (Though Pipelines are not part of anaesthesia machine, the pipelines carry gas from the central oxygen manifold storage unit in a intermediate pressure zone).
- Pipeline inlet connections.
- Pipeline pressure gauges.
- Ventilator power outlets.
- Oxygen flush valves.
- Oxygen failure alarm in older machines.
- Flow meter assembly.

## Low pressure system

(Part of the anaesthesia machine which is downstream of flow meters)

- Vaporisers
- Back pressure safety devices
- Common gas outlet

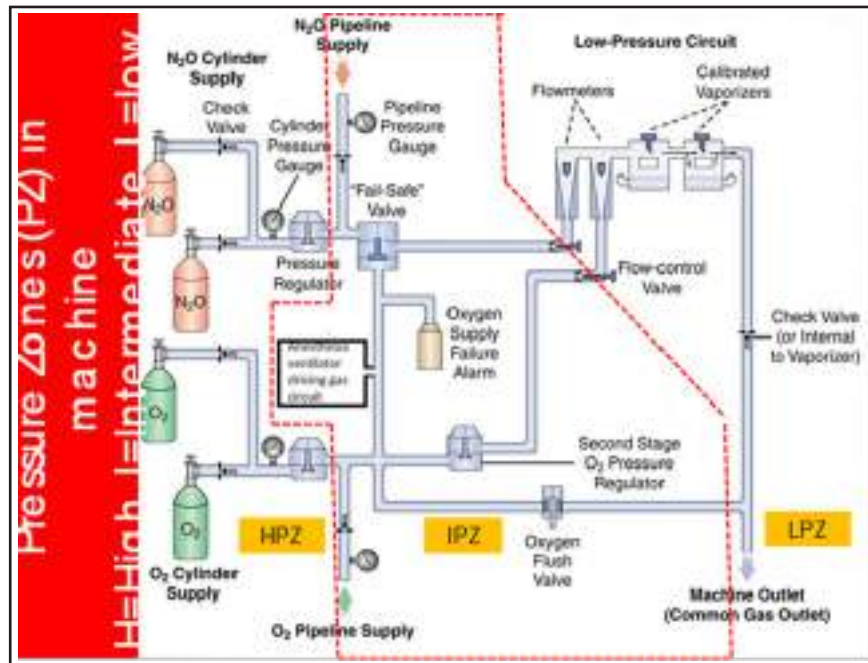


Figure 7: Pressure zones in anaesthesia machine

Let's have a look at all of the above in sequence

## High Pressure system

- In the previous section, we had already studied about gas cylinders, Yolk assembly components. Let's study the other components further in the anaesthesia machine from there.

Pressure gauges and Pressure regulators

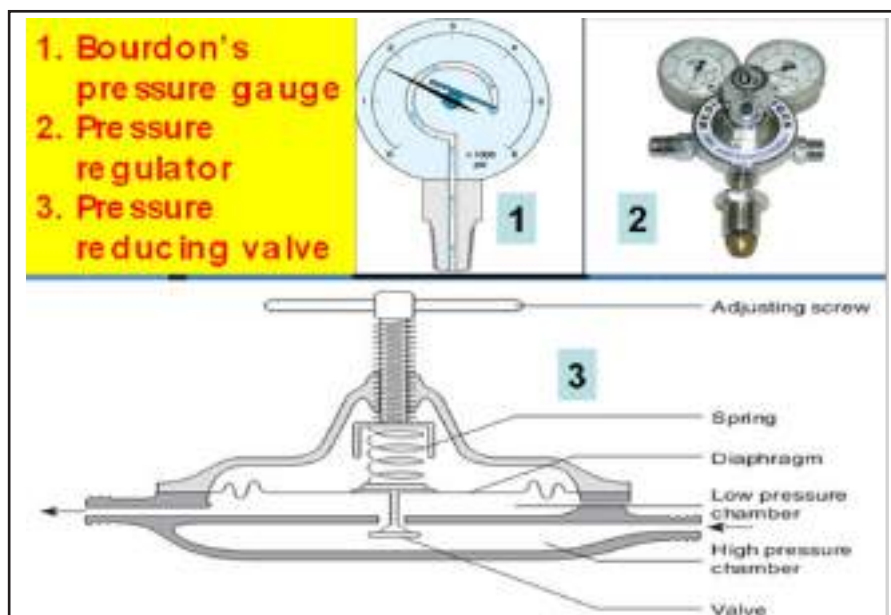


Figure 8: Pressure gauges and regulators



- All machines have a pressure gauge on the cylinder side of the regulator to measure the cylinder pressure. These gauges are usually of Bourdon type. (Figure No 8 )
- They consist of a hollow metal tube, bent into part of a circle, connected to the pressure line.
- The application of pressure to the inside of the tube causes the tube to straighten and this movement is transmitted through a clockwork mechanism to the indicator needle.

### Pressure regulator

- Pressure regulators convert the high, variable pressure in the cylinder into a constant working pressure suitable for use in anaesthesia machines.  
(say a pressure of around 2200 Psig from cylinder reduced to pressure of around 40 to 55 psig)
- Because of the use of pressure regulators frequent adjustments are not necessary to maintain a constant flow, fine adjustment of low flow is possible, and there is less chance of bursting of the tubing and blowing up of connections.
- As a safety mechanism it was noted that there should be a mechanism to cut off flow of nitrous oxide immediately if the oxygen flow is interrupted, say if the oxygen pressure drops in the cylinder because of the cylinder getting empty. Thus the concept of "Master slave oxygen pressure regulator" controlling the "slave pressure regulator" of nitrous oxide was thought of and incorporated into newer Boyle's machines.
- This device is designed to prevent delivery of anaesthetic gas without oxygen, when the oxygen supply fails. This is incorporated at the level of the pressure regulators. The oxygen pressure regulator works as the primary regulator. The output from this regulator controls the secondary regulators of the slave regulators that are located in the N<sub>2</sub>O line. In such systems, if the pressure from the oxygen regulator falls, the slave regulator of nitrous oxide will automatically close and will not allow flow of N<sub>2</sub>O.
- These are two types: one, in which the N<sub>2</sub>O regulator will be totally cut off, when the oxygen pressure falls below a critical level, and the other, where the N<sub>2</sub>O outlet pressure will also fall proportionate to the fall in O<sub>2</sub> pressure and so the proportional flow will be maintained, though the total flow will fall and finally stop.
- However, it is important to note that this is not a full proof oxygen failure and hypoxia prevention mechanism. If oxygen at the flowmeter was accidentally cut off, it was still possible to deliver nitrous oxide as hypoxic mixture since the master and slave regulator mechanism will not work here since the pressure regulator reads that the pressure in master regulator is adequate and thus the slave regulator will still deliver the nitrous flow to the flowmeters.

### Intermediate pressure system

#### Oxygen Flush:

- A direct metal tube brings out the oxygen from oxygen pressure regulator at intermediate pressure at flows of 35 – 60 litres / minute to the outlet port
- This is useful for emergency bag and mask ventilation with significant leak occurring or can be used in jet ventilation.
- It is pure oxygen which is delivered irrespective of whether the volatile agent vaporiser is on or off
- Though useful, because of the pressure and high flows, it has tendency to cause barotrauma or awareness because of dilution effect when used for long time.



### Oxygen pressure failure warning devices:

- It is mandatory that in addition to cutting off N<sub>2</sub>O flow, there should be an alarm that alerts the anaesthesiologist to a failing O<sub>2</sub> supply.
- Devices have been developed which activate an alarm when the oxygen pressure falls to a certain critical level. The alarm may be visual, audible or both.
- With the activation of alarm, the device either cuts off the N<sub>2</sub>O flow or directs the N<sub>2</sub>O flow to the atmosphere.
- The present Boyle's machine made by Indian oxygen limited (namely the 'Boyle Basic' 'Boyle Tec' and 'Boyle Ultima') incorporate a device with a small oxygen tank. This tank is pressurized during normal use. When the oxygen pressure at the source falls, the oxygen from this small cylinder flows through a whistle, incorporated on line, giving rise to an audible alarm for a period of seven to ten seconds. Cessation of the alarm does not mean that the alarm condition has been rectified and measures must be taken to correct it.
- The oxygen pressure failsafe systems and warning devices control the gas in its associated gas line in response to the pressure in oxygen line. Its safety potential is limited. It will permit administration of hypoxic gas mixtures when the gas flow is erroneously composed with low oxygen flow, the oxygen flow control valve is accidentally adjusted downward, or the oxygen piping system contains a gas other than oxygen.

### Flow meters:

- All the flow meters have a flow control valve, a graduated stem to measure the flow, and an outlet.
- The flow control valve is a needle valve or pit valve used to adjust the amount of gas entering the flow meter. It consists of a body, a stem that screws into the body and ends in a pin, and a seat.
- The control knob attached to the stem will control the relative position of the pin to seating and hence the orifice for the gas flows. The gland of the flow control valve is filled with packing material to maintain a grip on the stem. If the packing is not tight, the flow control knob may become very loose and flow alterations may occur accidentally even with slight touch.
- A flow meter measures the flow-rate of the gas passing through it. The one used in modern anaesthetic machines is of the variable orifice type. It consists of a transparent tapered tube known as Thorpe tube. It has a smaller bore at the bottom than the top.
- It contains a float, which has oblique notches cut in the rim, and rotates freely in the middle of the gas stream without touching the walls of the tube and hence called a rota meter. The taper of the bore of the rota meter tube varies in order to elongate a part of the scale at the bottom. 'Low flows' can be more accurately measured because of this construction.
- The gas flow pathway between the float and the tube varies from top to bottom. At the bottom of the rota meter, it is tubular and the flow rate is more dependent on the viscosity of the gas. As the tube widens above, it becomes an orifical flow and flow rate is dependent on the density of the gas.
- The flow meters are individually calibrated with their floats for a particular gas at a specific temperature and pressure. The flow meter calibrated for one gas cannot be used for another with the same calibration as the viscosity and density of the gases differ.
- The flow meter will read an inaccurate flow if the float sticks to the tube. Sticking may be because of the mounting of the tube is not vertical, static electricity or dirt on the tube or float.

## Arrangement of Flow meters

- Conventionally, the oxygen flow meter is at the extreme left followed by CO<sub>2</sub>, C<sub>3</sub>H<sub>6</sub> and N<sub>2</sub>O. In the present day machines, the CO<sub>2</sub> and C<sub>3</sub>H<sub>6</sub> flow meters are removed and replaced with air flow meter. Some machines have only oxygen and nitrous oxide flow meters.
- Flow meter sequence can be a cause for delivery of hypoxic mixture. Normal gas flow in the flow meter assembly is from bottom to top and from left to right at the top.
- If oxygen is upstream and a leak occurs through the flow meter not in use, a substantial portion of oxygen can pass through the leak whereas nitrous oxide is directed towards the common gas outlet leading to delivery of hypoxic mixture.
- One safety measure taken at this level, by the American Society of Testing and Material (ASTM), is to keep the oxygen flow meter downstream of all the flow meters in the flow meter manifold.
- At this position, the oxygen will be directed towards the common gas outlet and the leak will be that of N<sub>2</sub>O. The Indian manufacturer, Indian Oxygen Limited, follows these guidelines and places the oxygen flow meter downstream. But other manufacturers do not follow these guidelines and keep the oxygen flow meter upstream. This is dangerous, because users unfamiliar with a particular anaesthesia machine might reach for the site where they were used to finding the control knobs. Because the position of the control knobs is reversed, they might turn off oxygen instead of nitrous oxide.
- A uniform standard is very much needed in this regard in our country. A leak in the oxygen flow meter tube between the float and the manifold can cause selective loss of oxygen.

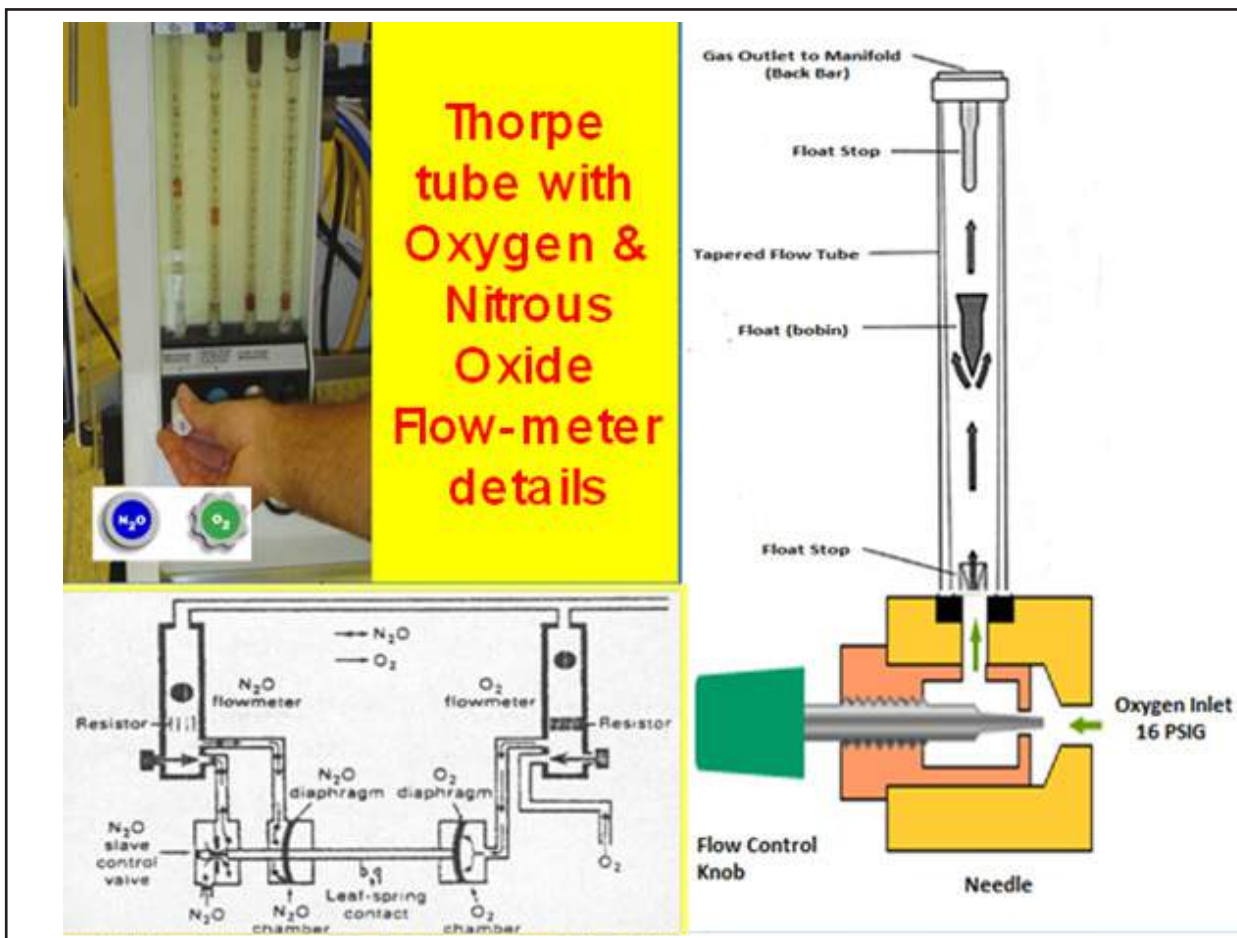


Figure 9: Flowmeter

## Oxygen ratio control devices:

- Most modern machines used in all developed countries utilize proportioning systems in an attempt to prevent delivery of a hypoxic mixture. Oxygen and nitrous oxide are interfaced either mechanically or pneumatically so that the minimum oxygen concentration at the common outlet is 25 percent.

### A. Oxygen Ratio Monitor:

- Recognising the limitations of the oxygen pressure fail-safe system, the manufacturers of the 'Dragger' machine developed a device called Oxygen Ratio Monitor (ORM). It is incorporated at the level of the flow meter.
- The ORM consists of a set of linear resistors inserted between the oxygen and nitrous oxide flow control valves and the respective flow meter. The pressure drop across the resistors is monitored and transmitted via pilot lines to an arrangement of opposing diaphragms. These opposing diaphragms are linked together with the capacity of closing a leaf spring contact and activating an alarm in the event of oxygen percentage in the mixture of oxygen and nitrous oxide dropping below a certain predetermined value.
- The ORM generates an alarm but does not actively control the gas flow. It will not sound an alarm if a hypoxic mixture is administered when the oxygen piping system contains a gas other than oxygen.

### B. Oxygen Ratio Monitor Controller (ORMC):

- This not only monitors the ratio of oxygen flow and gives an alarm when it falls below 30% but also reduces the flow of N<sub>2</sub>O correspondingly to maintain the ratio. The basic design principles are similar to ORM with the exception that a slave regulator is additionally controlled by the mechanism of opposing diaphragms, which controls the nitrous oxide delivery pressure to the nitrous oxide control valve, and thus, the nitrous oxide flow.
- The advantage of ORM is its capability to automatically respond to reduction in oxygen pressure or operator error. The disadvantage is that the operator cannot override the function of the device when desired.
- Ohmeda anaesthesia machines as well as the 'Boyle's ultima' machine introduced in India use this Link-25 proportion limiting control device. The heart of the system is the mechanical integration of the nitrous oxide and oxygen flow control valves. It allows independent adjustment of either valve, yet automatically intercedes to maintain a minimum oxygen concentration of 25%. In this system, the nitrous oxide has a gear with 14 teeth, which is fixed to the spindle. The oxygen has a gear with 29 teeth, which is mounted on the oxygen spindle with threads so that it can float over the spindle. For every 2.07 rotations of the nitrous oxide spindle, the oxygen gear will rotate once.
- The thread mounting of the oxygen gear allows independent rotation of the oxygen flow control valve. The link arrangement is so set, that opening of nitrous oxide will always rotate the oxygen gear, but the gear itself will engage the oxygen control valve spindle only when the proportion of nitrous oxide in the mixture exceeds 75%. The flows in the flow meters are precisely linked to the rotation by regulating the supply pressure of these gases with secondary regulators situated just before the flow meter. The N<sub>2</sub>O is supplied at 26 psig and oxygen at 14 psig. This combination of pneumatic and mechanical control maintains the minimum oxygen percentage at 25% whenever a mixture of oxygen and nitrous oxide are used. The oxygen percentage can be independently varied between 25 and 100.
- The disadvantage of this system is in the mechanical linkage. If the spindle and the gear are not properly aligned or if the threads in the spindle undergo wear and tear, the link system is likely to malfunction. Secondly, the proportioning devices can link only oxygen and nitrous oxide. If a

third gas like air is included in the flow meter assembly, then it no longer assures a 25% oxygen delivery in the mixture. Most of the modern machines allow an air flow meter in the flow meter block.

## Low pressure system

### Vaporisers

- Sir WTG Morton in 1846 demonstrated for the first time in public that ether could be used as surgical anaesthetic through inhalational method. Since then the inhalational agents have come long way in the terms of new compounds being invented with more safe and desirable features along with more precision in the inhalational agent delivery system i.e. Vaporisers technology.
- The Vaporisers are mounted on the back bar carrying the gas from the flowmeter and which has mounting system (may slightly vary from company make) for vaporisers to be mounted.
- Inhalational agents like Halothane (largely being phased out), Isoflurane, Sevoflurane come as liquid in room temperature and at normal ambient pressures in air tight sealed bottles which need to be poured into appropriate vaporisers to be converted into vapours which will be carried by the medical gases coming from the flowmeter to the patient's lung through breathing system.
- It is desirable to know the principles that affect the vaporiser output through a vaporiser.
- Modern Vaporisers are
  - Flow compensated
  - Temperature compensated
  - Concentration calibrated
  - Dial controlled – straightforward reading
  - Minimally or not at all affected by positive pressure ventilation devices on anaesthesia machine.
- An ideal vaporiser should deliver an reliable – accurate concentration of anesthetic vapour as per the dial setting concentration.
- The most common type of vaporiser, splits the fresh gas flow coming from the flowmeters in such a way that a portion of gas only reaches the vaporising chamber of the vaporiser which houses the inhalational agent liquid and the rest of the gas bypasses the vaporiser. This is called as variable bypass vaporiser.
- The dialled concentration, saturated vapour pressure, temperature, boiling points of the liquid, thermostat bimetallic strip, all determine how the vaporiser splits and carries the gas.
- This gas which has entered the vaporising chamber while leaving the vaporiser carries along with it the vapour of inhalational agent in precise amount as per the above mechanism and then mixes back with the split gas and is delivered then through the pipeline at the common gas outlet. From here the breathing circuit carries this mixture of medical gas along with inhalational agent vapour as per set dialled concentration to the patient's lung through the airway interface.

### Back pressure safety relief POP off Valve

- There is a relief valve downstream of vaporisers at the end of the back bar.
- This valve opens at pressure of 5PSIG (e.g. in case if the common gas outlet gets obstructed for some reason) so that this increased pressure is not carried to the vaporisers and flow meters damaging them and affecting their output function.



## Common Gas outlet

- Common gas outlet is the terminal where the anaesthesia machine's gas along with inhalational agent vapour mixture is released to atmosphere – and the breathing system is connected here so that these are then carried to the patient.
- This common gas outlet has a mechanism to divert this gas mixture through a switch mechanism to closed circuit system wherein the gas mixture will then pass to the patient through CO<sub>2</sub> circle absorber closed circuit system (either through manual closed circuit breathing or ventilator) or through open circuits. This depends upon the switch position.

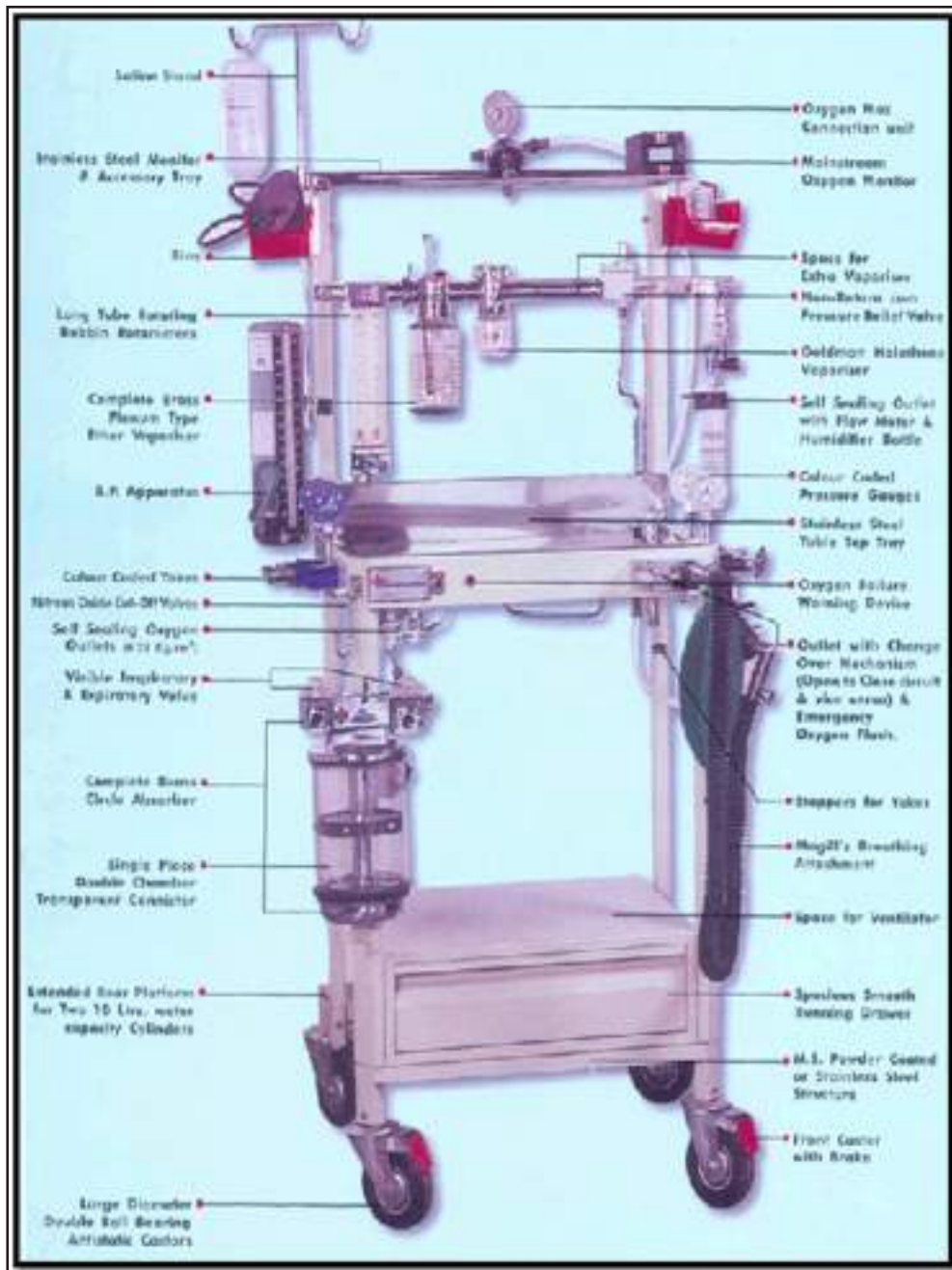


Figure10: Boyle's machine

The basic machine has undergone a lot of modification in the light of electronics and evolved as a modern anaesthesia machine. The advent of the computer gives us a new generation of anaesthesia gas machines, which have a great deal of added functionality in a small package, designed from the

start to be microprocessor controlled. These gas machines are being used due to enhance patient safety. Here under are the pictures of Modern Anaesthesia machines.

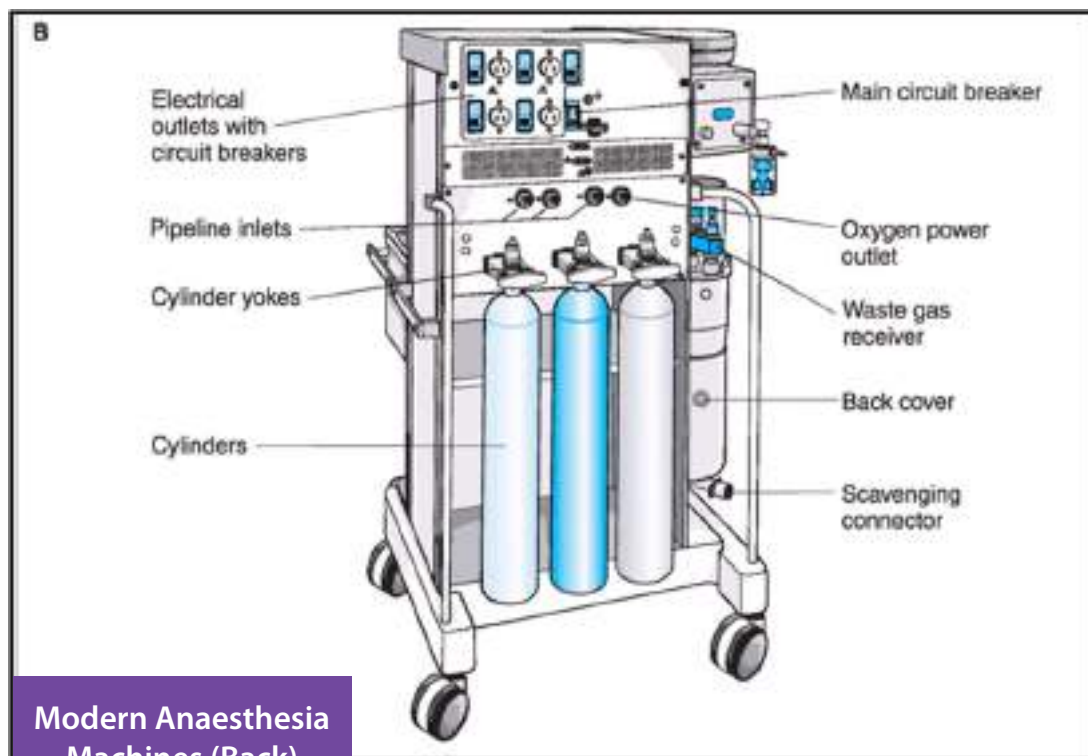
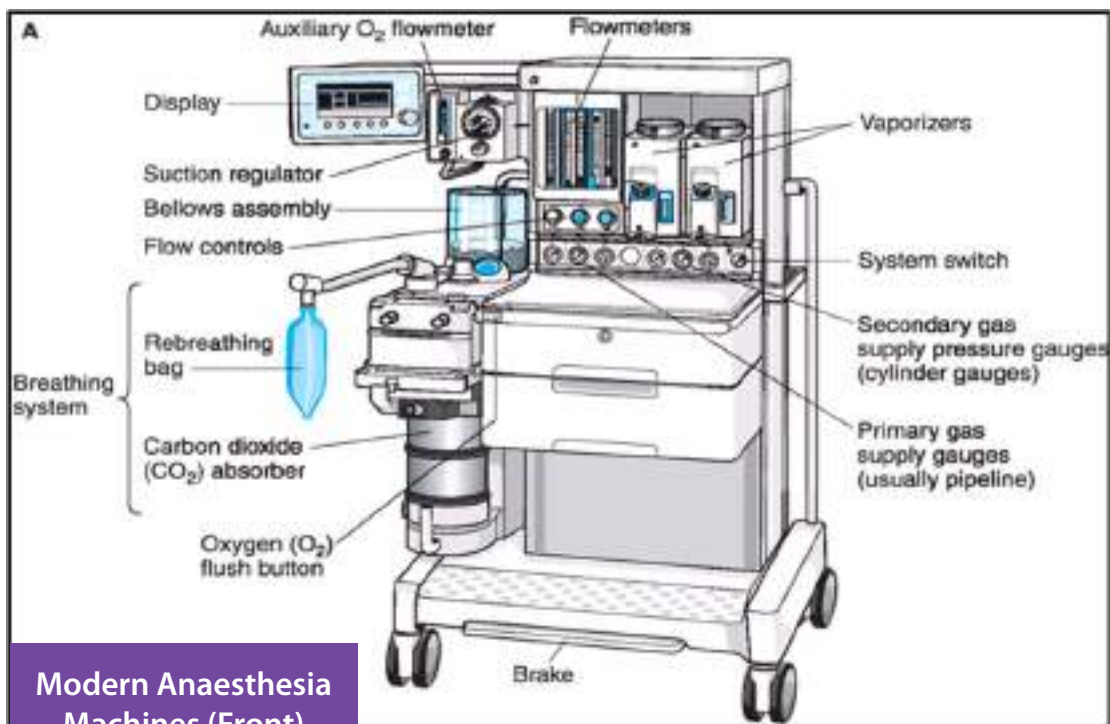


Figure 11: Modern Anaesthesia workstation

### Anaesthesia breathing circuit:

Breathing systems provide the final conduit for the delivery of anaesthetic gases to the patient. Many modifications in circuit design have been developed. One of the commonest of which is Mapleson system. The two most commonly used Mapleson breathing circuits are the Bain circuit (Mapleson-D)

and Jackson-Rees modifications of Ayre's T-piece (Mapleson-F), which will be described.

#### Bain Circuit:

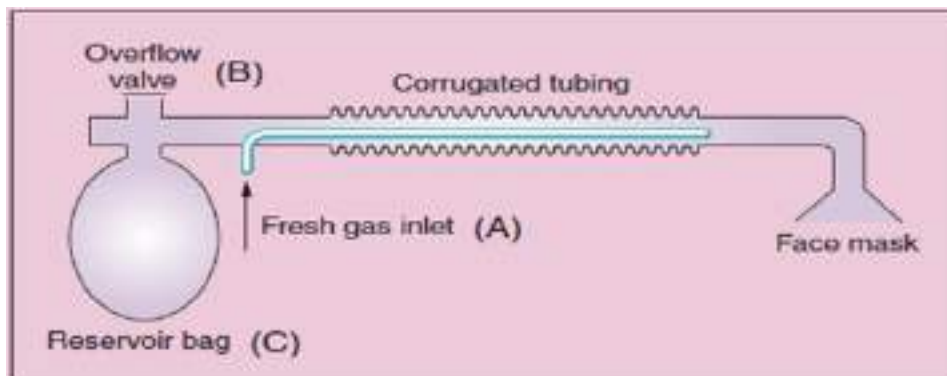


Figure12: Bain Circuit

Bain circuit is a co-axial modification of Mapleson-D system, in which the fresh gas tube runs within the expiratory tube. The diameter of the outer tube is about 22 mm and is made of corrugated plastic, and the diameter of the inner tubing is about 7 mm. The length of the commonly used Bain circuit is about 1.8 meters. The fresh flow required to prevent re-breathing during spontaneous ventilation is 2-3 times the minute ventilation (200-350 ml/kg) and during controlled ventilation is 1-2 times the minute ventilation (100-200 ml/kg).

#### Advantages:

- It is the most efficacious circuit for controlled ventilation.
- Universal nature.

#### Jackson-Rees modification of Ayre's T-piece:



It is the circuit most commonly used in the paediatric age group (<20-25 kg). It is basically a T-piece with an open-ended reservoir bag attached at the end of the exhalation tubing. The volume of the exhalation tubing and reservoir bag should exceed the tidal volume of the patient. The fresh flow required is 2-3 times the minute ventilation.

#### Advantages:

- It can be used for both spontaneous and controlled ventilation.
- It is valve less, minimizing the resistance to breathing.

#### Disadvantages:

- It needs higher flow rate in controlled ventilation as compared to Bain circuit.



- Less efficacious in preserving heat and humidity.

### Closed Circle system:

- Gas mixture exhaled by the patients are allowed to be passed through the carbon dioxide absorption system. This Almost CO<sub>2</sub> gases are then passed back to the patients thus helping conserve the gases. This circuit of the gas flows is arranged in a peculiar circular way and is called as the closed circuit system.
- This results in:
  - Low utilisation of fresh gas flows thereby conserving the gases.
  - Inhalational agents are also conserved and recirculated back and leads to inhalational agents being conserved.
  - Inhalational agents by not allowing to be leaked continuously in operation theatre thus results in significantly less operation theatre and by the virtue of same less environmental pollution.
  - Cost effective and economical.
  - Heat and moisture are conserved in the above process.
  - Able to practice low flow anaesthesia .
- Requirements:
  - Unidirectional Valves and two separate respiratory limbs for inhalation and exhalation.
  - CO<sub>2</sub> Absorber – e.g. Soda lime canister attached in the circle system.
  - Source of fresh gas flow including inhalational agents gas mixture from machine being incorporated in to the circle system.
  - Adjustable pressure limit valve.
  - Y – piece.

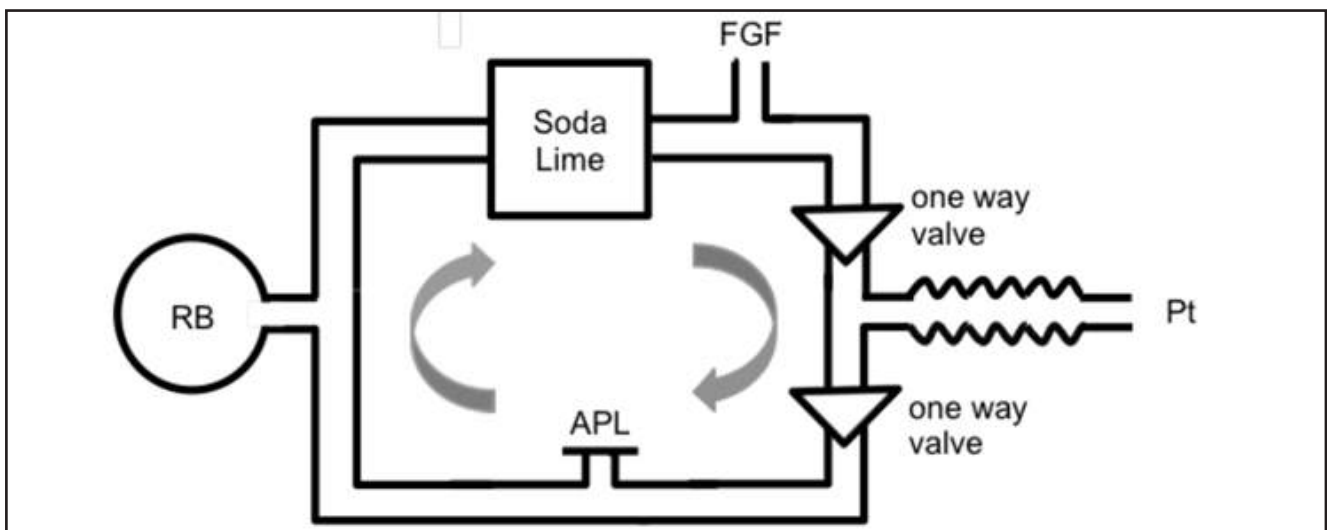


Figure10: Closed Circuit System

- CO<sub>2</sub> Absorbent System – e.g Soda lime
  - This has practically become the most important component of the closed circuit system conceptually

- There are multiple agents available, soda lime being one of the most common agents. It has:
  - Calcium Hydroxide: 80%
  - Sodium Hydroxide: 4%
  - Water: 16%
  - PH Sensitive dye – colour indicator to let know that the agent is exhausted

# 17

## Readiness and Checklist of Anaesthesia Machine

---

### SAFETY MEASURES IN ANAESTHESIA MACHINE:

#### To prevent delivery of excessive anaesthetic concentration:

There are few situations in which excessive anaesthetic concentration can be delivered to the patient.

- The first is delivery of a fully saturated gas mixture, which is most often the result of liquid anaesthetic spilling into the fresh gas delivery system. Non-precision vaporizers such as the Goldman vaporizer are often used by mounting it in the common gas outlet. They are likely to get accidentally disconnected from the machine, spilling the liquid anaesthetic into the breathing system. This is a very dangerous situation and very high concentration of the anaesthetic can be inhaled if the vaporiser is connected back to the machine and used. Vaporisers designed in the last ten years are precision vaporizers, which do not allow this to happen as they are mounted on the machine. Laying the vaporiser on its side or turning it over will cause the liquid anaesthetic to spill into the bypass chamber with the same end result.
- Another dangerous situation is when the vaporiser is filled with a wrong anaesthetic agent. For example, methoxyflurane vaporiser filled with halothane or isoflurane will deliver a very high concentration endangering the life of the patient. So, to prevent this, agent specific fillers are attached to the bottle which will only get attached to agent specific vaporizer (Keyed filling devices). Another situation when excessive anaesthetic concentration can be delivered is, when the carried gas used is changed from N<sub>2</sub>O to air-oxygen or oxygen alone. This is because of the ability of N<sub>2</sub>O to dissolve in the liquid anaesthetic and get liberated when it is cut off. It is estimated that 100 ml of halothane can dissolve 450 ml of N<sub>2</sub>O. This will be released from the liquid when N<sub>2</sub>O is cut off, increasing the amount of carrier gas exiting the vaporizing chamber and thereby increasing the vapour concentration. The following safety measures have been incorporated in modern machines to prevent some of the above mentioned causes:
  - Use of back flow check valve at the common gas outlet, so that the fluctuations in pressure during controlled ventilation are not transmitted to the vaporisers.
  - The construction of the vaporisers has been modified to make them back pressure compensated vaporisers so that both pumping effect and pressuring effects are negated.
  - The size of the common gas outlet has been changed from 23 mm female to 22 mm male/ 15 mm female connector to prevent connection of vaporiser to common gas outlet.
  - Vaporisers with liquid anaesthetic inside should be handled carefully without tilting or turning. If the vaporiser is accidentally tipped or lid on its side, it should be emptied and then flushed with a high flow of oxygen with concentration dial turned set to the maximum for at least 10 minutes before using the equipment on patients.
  - Only one precision vaporiser should be used at any time, so that condensation of liquid -

anaesthetic does not take place into another vaporiser. To prevent simultaneous use of two vaporisers, the contemporary machines are fitted with vaporisers, which have a locking mechanism, which prevents a second vaporiser to be opened without closing the first one.

- Keyed filling devices are available for most newer inhalation agents to prevent the use of a volatile anaesthetic in a given vaporiser.

### **To prevent development of excessive pressure on the machine and breathing systems:**

- To prevent development of excessive pressures in the machine, pressure relief valves are incorporated into the intermediate pressure system and low pressure system of the machine, and also in the breathing systems connected to the patient. There is one pressure relief valve after the pressure regulator. If there is a defect in the pressure regulator the intermediate pressure system is protected from the high pressures by this relief valve, which will release the pressure to the atmosphere.
- The flow meter and the vaporisers are protected by a pressure relief valve situated before the common gas outlet. If there is obstruction to flow at or after the common gas outlet, the pressure in the low pressure system rises and the relief valve will open when the pressure exceeds 200 cm H<sub>2</sub>O (in Boyle's machine). This is mainly to protect the flow meter and the vaporisers.
- All breathing systems have an adjustable pressure-limiting (APL) valve, which opens the system to the atmosphere. The opening pressure of this valve is adjusted normally according to the breathing system used and its applications. Occasionally, this valve may get stuck and allow development of high pressure. If such an event occurs, the system should be immediately disconnected from the patient to avoid barotrauma. If the fault cannot be rectified, alternative methods (Ventilation with AMBU's Bag, Bain's Circuit or T-piece connected with any oxygen source) should be used to ventilate the patient and the breathing system should be changed. Some of the APL valves manufactured now-a-days vent gases to the atmosphere when the pressure exceeds 60 cm H<sub>2</sub>O even when they are fully closed. Another safety feature in the breathing system is the reservoir bag. Most of these bags give way when the pressure builds up above 50 cm H<sub>2</sub>O.

### **CHECK OUT PROCEDURE TO BE FOLLOWED EVERYDAY BEFORE USING THE MACHINE:**

#### **High pressure system:**

Check high-pressure system to prevent connection of wrong gas.

- Check the gas cylinders by color-coding and by label to confirm they are connected to the correct yoke.
- Open O<sub>2</sub> cylinder and verify at least half the cylinder is full (1000 psig) for emergency use.
- Open the oxygen flow control valve and register a flow of 4-5 lit/min.
- Open the nitrous oxide flow control valve and note that the flow meter does not register a flow.
- Close the cylinder and note the flow meter bobbin falls to zero.
- Listen for oxygen pressure fail alarm is present.

Check oxygen pressure fail-safe mechanism.

- Open N<sub>2</sub>O cylinder and note the pressure in the pressure gauge (750 psig).

- Open the N<sub>2</sub>O flow meter. It should not register any flow, as the oxygen line is not pressurized.
- Open the oxygen cylinder. Now, flow should be registered in both oxygen and nitrous oxide flow meters.
- Close the oxygen cylinder and note the flow meter bobbins in both fall to zero and oxygen pressure fail alarm is activated.
- Close the N<sub>2</sub>O cylinder, and both the flow control valves.

#### Check the pipeline supply. Hose test.

- Connect the oxygen pipeline to the oxygen wall outlet. Open the oxygen flow control valve to note that it registers a flow. This confirms that oxygen is flowing into the oxygen flow meter and there is no cross over of the flexible pipeline.
- Open the N<sub>2</sub>O flow meter and note that the flow meter bobbin falls to zero after registering initial flow. (The flow is from the N<sub>2</sub>O pressure regulator, which has not been released after closing the N<sub>2</sub>O cylinder).
- Connect the N<sub>2</sub>O pipeline to the wall outlet and note that the N<sub>2</sub>O flow meter registers a flow.
- Disconnect O<sub>2</sub> pipeline and note both flow meter bobbins fall to zero. Reconnect O<sub>2</sub> pipeline.
- Check the pipeline pressure to be between 55-60 psig (4-4.2 Kg/cm<sup>2</sup>) if the machine is provided with a pipeline pressure gauge.

### Low Pressure System:

#### Check initial status of low-pressure system. (From flow control knob to the common gas outlet)

- Close the flow control valves and turn vaporizers off.
- Check fill level and tighten vaporizer's filler caps.

#### Perform leak check of machine low-pressure system.

- Verify that flow control valves are closed.
- Attach suction bulb to common gas outlet.
- Squeeze bulb repeatedly until fully collapsed.
- Verify the bulb stays fully collapsed for at least 10 sec.
- Open the vaporizer one at a time and repeat above steps.
- Remove suction bulb and reconnect fresh gas hose.

#### Test flow meter

- Adjust flow of the gases through their full range, checking for smooth operation of the floats.
- If the machine has a proportioning device, attempt to create a hypoxic gas mixture and verify the correct changes in flow.

Turn on the main switch of the machine (if it has one) and all the electrical monitoring equipment. Connect the breathing system and the oxygen analyzer (if available) to the common gas outlet.

#### Calibrate oxygen analyzer if available.

- Calibrate to read 21% in room air.

- Connect to common gas outlet and flush with 100% oxygen
- Verify if it reads above 95%.

### **Breathing System:**

#### Check initial status of breathing system

- Check the breathing system is complete undamaged and unobstructed.
- Verify the CO<sub>2</sub> absorbent is OK. Colour change, shows, it is exhausted and needs replacement.
- Connect the breathing system accessories to be used during the case.

#### Perform leak test of the breathing system.

- Set all gas flows to Zero.
- Close APL valve and occlude patient end.
- Pressurize system to 30 cm H<sub>2</sub>O using O<sub>2</sub> flush.
- Squeeze bag and check for leak.

#### Checking the integrity of inner tubing -Bain Circuit

- Direct inspection of the circuit.
- Register a flow of 500 ml oxygen.
- Occlude the inner tube and note the flow meter bobbin falls slightly.
- Release occlusion and note the bobbin coming back to original level.

Check the ventilation system if a ventilator is attached to the anaesthesia machine (check procedure as per the manufacturers' instructions).

#### Check Laryngoscope and intubating accessories

- Check laryngoscope light is adequate Keep two functioning Laryngoscopes).
- Keep appropriate endotracheal tubes, masks and airways.
- Suction apparatus (Two functioning suction apparatus, one for Anaesthesiologist and other for Obstetrician).

#### Check, calibrate and set alarms for all monitors as required

- ECG.
- Capnography.
- Pulse oximeter.
- Blood pressure monitor.
- Airway pressure monitor.
- Anaesthetic gas monitor.

### Check Final status of Machine

- Vaporizers 'off'.
- All flow meters to Zero.
- APL valve open.
- Reservoir bag in place.
- Patient suction level adequate.
- Breathing system ready to use.

### Check Out to be carried out Daily:

Item no.	Item to be completed	Responsible Party
1	Verify auxiliary oxygen cylinder and self-inflating manual ventilation device are available and functioning	Anaesthesia Care Provider and Technician
2	Verify patient suction is adequate to clear the airway	Provider and Technician
3	Turn on anaesthesia delivery system and confirm that AC power is available	Provider or Technician
4	Verify availability of required monitors, including alarms	Provider or Technician
5	Verify that pressure is adequate on the spare oxygen cylinder mounted on the anaesthesia machine	Provider and Technician
6	Verify that the piped gas pressure are more than or equal to 50psig	Provider and Technician
7	Verify that vaporizers are adequately filled and if applicable that the ports are tightly closed	Provider or Technician
8	Verify there are no leaks in the gas supply lines between the flow meters and the common gas outlet	Provider or Technician
9	Test scavenging system function	Provider or Technician
10	Calibrate or verify calibration of the oxygen monitor and check the low flow oxygen alarm	Provider or Technician



Item no.	Item to be completed	Responsible Party
11	Verify carbon dioxide absorbent is not exhausted	Provider or Technician
12	Breathing system pressure and leak testing	Provider and Technician
13	Verify that the gas flows properly through the breathing circuit during both inspiration and expiration	Provider and Technician
14	Document completion of check-out procedures	Provider and Technician
15	Confirm ventilator settings and evaluate readiness to deliver anaesthesia care (Anaesthesia time out)	Provider

#### Check out to be carried out Before each procedure:

Item no.	Items to be completed	Responsible Party
2	Verify patient suction is adequate to clear the airway	Provider and Technician
4	Verify availability of required monitors, including alarms	Provider or Technician
7	Verify that vaporizers are adequately filled and if applicable that the ports are tightly closed	Provider
11	Verify carbon dioxide absorbent is not exhausted	Provider or Technician
12	Breathing system pressure and leak testing	Provider and Technician
13	Verify that the gas flows properly through the breathing circuit during both inspiration and expiration	Provider and Technician
14	Document completion of check-out procedures	Provider and Technician
15	Confirm ventilator settings and evaluate readiness to deliver anaesthesia care (Anaesthesia time out)	Provider

## SALIENT POINTS TO REMEMBER:

- Check all your equipment, including the anaesthesia machine and breathing circuit before you start.
- The oxygen cylinder must be at least half full and other cylinders must be available immediately at hand before administration of anaesthesia.
- Ensure that the bobbins are freely moving and rotating during the flow of gases.
- Most modern anaesthesia machines have a number of safety features to prevent the delivery of a hypoxic mixture and development of excessive pressures.
- Problems can occur despite incorporation of safety features in machine.
- Checking the anaesthesia machine before providing anaesthesia is the responsibility of the anaesthesia provider.
- Regular checking and proper maintenance of anaesthesia machine can avoid mishaps from happening.
- Always keep ready the Auxiliary circuit (Bain's or Paediatric-Ayre's T piece) and AMBU bag with oxygen for ventilation in case of an emergency of Machine failure.

## CHECK YOUR PROGRESS:

- Oxygen cylinder is usually made of:
  - Iron
  - Copper
  - Silver
  - Molybdenum steel
- The following gases are stored as compressed gas except:
  - Oxygen
  - Nitrogen
  - Air
  - Nitrous oxide
- Carbon-dioxide and \_\_\_\_\_ are stored as liquid.
- The filling ratio of nitrous oxide in tropics is:
  - 0.47
  - 0.77
  - 0.67
  - 0.87
- The color-coding of nitrous oxide is \_\_\_\_\_ .
- The pin index number for oxygen is:

- a. 3-5
  - b. 2-5
  - c. 4-5
  - d. 1-5
- vii. The flow rate of gases at the bottom of the flow meter is dependent on:
- a. Viscosity of the gas
  - b. Density of the gas
  - c. Total flow of the gas
  - d. All of the above
- viii. Which of the following arrangement of flow meter do you think is safe for the patient:
- a. Oxygen on the extreme left
  - b. Oxygen on the extreme right
  - c. Safety is not effected by the position of the flow meter
  - d. None of the above
- ix. In the oxygen ratio control devices the minimum oxygen concentration at the common gas outlet is:
- a. 20%
  - b. 25%
  - c. 30%
  - d. 35%
- x. The pressure regulators in all modern anaesthesia machines are preset to:
- a. 45-55 psig
  - b. 55-65 psig
  - c. 65-70 psig
  - d. 70-80 psig
- xi. The pressure relief valve at the common gas outlet opens at:
- a. 10 psig
  - b. 5 psig
  - c. 15 psig
  - d. 20 psig

**Reference and Further Readings:**

- Understanding anaesthesia equipment (Dorsch & Dorsch).

- Anaesthesia equipment (Wards).
- Srivastava U. Anaesthesia gas supply: Gas cylinders. Indian J Anaesth 2013;57:500-6
- Das S, Chattopadhyay S, Bose P. The anaesthesia gas supply system. Indian J Anaesth 2013;57:489-99
- Gurudatt CL. The basic anaesthesia machine. Indian J Anaesth 2013;57:438-45
- Breathing Systems in Anaesthesia: WFSA Tutorial 333 July 2016

# 18

## Anaesthesia Monitoring System

### INTRODUCTION:

- Though Anaesthesiology is one of the recent specialities in medical sciences, it has taken giant steps in advancing towards the cause of patient safety and quality management. The patient safety and quality improvement track records in anaesthesiology are enviable when compared with other specialities. Anaesthesia monitoring standards which are continuously updated and anaesthesia records keeping has gone long way in achieving this important milestone.
- From an era of monitoring the patient's condition under anaesthesia with only clinical skills like colour of the patient, chest movement, pulse monitoring with fingers, precordial stethoscope, anaesthesiology has come up long way with multiple advanced workstations, electronic multipara monitors helping the Anaesthesiologist help keep tab on patient's condition in real time.

### LEARNING OBJECTIVES:

Learning Objective	Knowledge	Skills
Anaesthesia Monitoring standards	✓	
Monitoring of Airway , Breathing and Circulation along with CNS functions and temperature	✓	✓ Demonstrate various monitoring tools and its uses in patients under anaesthesia
Importance of monitoring	✓	

### ANAESTHESIA MONITORING STANDARDS:

- Many international societies have formed basic minimum standards for monitoring and have kept on updating them. While it is important to acknowledge that with the advent of newer technologies every day, there are lots of medical gadgets available and not all of them would be required in all the cases.
- It is important to emphasize that irrespective of type of anaesthesia practiced i.e regional anaesthesia, monitored anaesthesia care, general anaesthesia, there are some basic anaesthesia standard which needs to be implemented always.
- These basic standards can always be exceeded with more monitoring gadgets as per the resources

available as well as the type of case and patient's health condition.

- From a scientific point of view and also to make things easier and more schematic, classification can be roughly divided into human factors and gadgets. More important way to divide the minimum monitoring standards is by the organ system being monitored i.e. Airway, Breathing, Circulation, Mentation, temperature monitoring or assessment of oxygenation, ventilation, circulation along with mentation and temperature.

## IMPORTANT STANDARDS FOR ANAESTHESIA MONITORING

**1. No Anaesthesia should administered in the absence of qualified Anaesthesiologist** and he or she should always be physically present in the operating room/environment where any form of anaesthesia is being given to the patient and should not leave the patient till the procedure is completed and the patient is shifted to recovery room. He should ensure before leaving, that the patient, is out of the anaesthesia effects of the drugs given well enough to match the criterion to be shifted out of that place or be shifted under monitored care of the treating team.

### 2. Airway Monitoring / Adequacy of ventilation checking

- a. Patient undergoing general anaesthesia will have monitoring of airway confirmed by multiple methods. E.g. Chest rise and fall, movement of reservoir bag, auscultation, fogging in the endotracheal tube. But it is important to remember that all these above methods can have false negative results at times and therefore wherever available end tidal capnography (especially continuous quantitative graphical capnography in patients who have advanced airway inserted like – supraglottic airway device, endotracheal tube, tracheostomy) serves as the gold standard confirmatory method for confirming. Infact, endtidal carbon dioxide monitoring is mandatory when general anaesthesia is administered to any patient.
- b. End tidal capnography is helpful even in spontaneously breathing patients who are sedated or anesthetized without and advanced airway gadget.

### 3. Breathing

Breathing appropriate gas mixture is crucial for maintaining adequate oxygenation delivery to the tissues. As seen in the chapter on Anaesthesia machine, there are various ways to [prevent delivery of hypoxic mixture but even then monitoring the inspired gases can become important

- a. Inspired gases concentration of oxygen by oxygen analyzed depicting the  $FiO_2$  wherever feasible should be employed.
- b. Blood oxygenation monitoring: the advent of pulse oximeter as a continuous tool for monitoring the oxygen saturation has revolutionized the management in patient receiving any form anesthetics, emergency medicine or intensive care. Pulse oximetry should always be used. The pulse oximeter should preferably have variable pitch pulse tone which changes as per the saturation levels and should be clearly audible to the Anaesthesiologist always.

### 4. Circulation

It is important to assess the adequacy of cardiac output and peripheral perfusion during anaesthetic

- a. Continuous electrocardiogram monitoring is important and mandatory in all patients receiving anaesthetic.
- b. All the patient undergoing anaesthesia should have a blood pressure recording at least every 5 minutes taken and recorded.
- c. Additionally, one of the following should be employed in between especially in patients undergoing general anaesthesia i.e. intermittent pulse checking or auscultation of heart sounds or looking up of invasive blood pressure tracing if it has been employed because of the nature of the case taken.

## 5. Mentation

- a. Wherever appropriate (in patients who have not been given general anaesthesia), including patients coming out from general anaesthesia the Anaesthesiologist should observe the patient's mentation as pre and post anaesthetic comparison.

Early changes in mentation in a patient under anaesthesia who previously had normal mentation points to either the appropriate drug effects (say hypnotics being administered) or to serious side effects being developed because of complication of anaesthesia or a new unrelated underlying disorder.

**e.g.** seizures manifesting as local anaesthesia toxicity.

Loss of consciousness, weakness in upper limb and difficulty in breathing are few of the important features after spinal anaesthesia those may point towards high or total spinal anaesthesia complication.

## 6. Temperature

- a. It is important to maintain body temperature during all anaesthetic and especially in patients where temperature fluctuations are anticipated, temperature monitoring devices (importantly which will reflect core temperature) will be helpful. Rectal temperature probe, esophageal temperature probe is commonly used devices for this purpose. Temperature monitoring is very important in cases where massive blood transfusion is being given, especially, in a case of PPH where hypothermia is expected to occur, it will be desirable to monitor temperature.

## KEY POINTS TO REMEMBER

- An Anaesthesiologist should always be physically present whenever anaesthetic is in progress
- ECG, NIBP, SpO<sub>2</sub> along with continuous watch on ventilation and mentation of the patient where appropriate, is basic minimum which every Anaesthesiologist must follow meticulously.

## CHECK YOUR PROGRESS

- i. The five basic elements which are important during anaesthesia monitoring are \_\_\_\_\_  
\_\_\_\_\_.
- ii. When Monitoring the airway all the following can be helpful immediately except
  - a. Movement of reservoir bag / ventilator bellows if under GA



- b. Auscultation of chest
  - c. End tidal capnography
  - d. Electrocardiograph
- iii. Following monitoring helps in observation of circulatory system except
- a. Noninvasive blood pressure trace
  - b. Invasive arterial blood pressure test
  - c. Ventilator bellows getting adequately filled up
  - d. Pulse oximetry
- iv. Enumerate the, limitations of pulse oximeter.
- v. End tidal capnography as an indirect monitor for cardiac output monitoring. Comment.

**References:**

- Standards for Basic Anesthetic Monitoring Committee of Origin: Standards and Practice Parameters. (Approved by the ASA House of Delegates on October 21, 1986, last amended on October 20, 2010, and last affirmed on October 28, 2015)

# 19

## Premedication

### INTRODUCTION:

- Premedication in Anaesthesia is not a new concept and is widely practiced (though variably) but is undoubtedly an important component of safe Anaesthesia practice
- The practice of premedication started with use of chloroform and ether anaesthetic which were used around 19th century. The drugs used to take longer time to induce Anaesthesia, used to create a restlessness stage and also used to induce lots of secretions.
- Atropine and Morphine combination soon became a widely accepted premedication to have a calmer patient with less secretions as well as have antivagal action.
- With the advent of newer IV induction agents as well as newer inhalational agents with lower partition coefficients resulting in rapid induction, the practice of premedication “as usual” has become debatable but never the less premedication is not restricted to only two class of drugs but encompasses more than that.
- A good premedication is undoubtedly an important component of the Anaesthesia regime.

### LEARNING OBJECTIVES:

Learning Objective	Knowledge	Skills
Premedication, its components and importance	✓	
Various group of premedication drugs used. Their indications, contraindications, basic pharmacology including doses.	✓	✓ Observe, assist and prescribe premedication to patients peri-operatively under supervision. Note the doses, indications. Note in the logbook.

### WHAT IS PREMEDICATION AND WHAT ARE ITS GOALS?

- Premedication as normally accepted is the process of administering drugs 1-3 hours before induction of anaesthesia.
- However, the drugs given overnight in a fasting elective patient, managing drugs which the patient is taking for associated comorbidities can also be considered as part of premedication management.

- Giving premedication too early or too late will not have the desirable effect, but this needs to be balanced against the resources available in terms of equipment as well as manpower for monitoring the effects of premedication and treating any side effects very early. This practical consideration should always be thought of and appropriately implemented.
- The premedication in any given patient in today's modern era of Anaesthesia will rest on the following factors:
  - Patients comorbidity and the anticipated effect of premedication it will have on that comorbidity.
  - Individual needs as assessed by the paranaesthesia check-up.
    - Examples is postoperative nausea and vomiting score and indications to give the premedication to prevent them.
  - Type of surgery being performed.
  - Anaesthesia drugs and technique being utilised for the given patient.

### **BROADLY THE GOALS OF PREMEDICATION CAN BE STATED AS:**

- To reduce Anxiety and to produce Sedation, Amnesia.
- To reduce Salivary secretion.
- To prevent Aspiration.
- To reduce Post-Operative Nausea & Vomiting.
- Prevention of unwanted Vagal reflexes.
  - By Surgical stimulation.
  - By Certain drugs.
- For Analgesia - Intra and Post-operative.
- To reduce metabolic rate.
- To protect against allergic reactions if anticipated.
- To attenuate the sympathetic system reflex activity.
- For specific therapeutic effect.

### **LET US DISCUSS THE COMMONLY USED PREMEDICATION DRUGS:**

- Sedatives- Hypnotics / Anxiolytics
- Opioids. (separate chapter)
- Tranquillizers.
- Anticholinergic agents.
- Antacids, Antiemetic, Prokinetics.
- Drugs for specific effect: e.g. Steroids, Antihypertensive, Bronchodilators etc. (separate chapter)
- To suppress the reflex stimuli (neuroendocrine) along with GA induction and maintenance agents to surgical stimuli and ultimately help decrease the anaesthetic requirement for the given procedure by use of "balanced Anaesthesia"

## Sedatives and Hypnotics:

- Perioperative anxiety can occur in as high as 50 to 80% of the patients, more so in vulnerable group of patients like children, females.
- Anaesthesiologists visit and counselling during PAC, informing the patient as to what to anticipate as routine during perioperative significantly helps alleviate the anxiety. This is not universal for all patients as well as not 100% relief of anxiety in almost any given patient.
- Pharmacological agents help further in this, most commonly used group of drugs for this being the benzodiazepines (Midazolam, diazepam, Alprazolam)
- Benzodiazepines also produces anterograde amnesia.
- Midazolam is one of the most commonly used drug in premedication prior to surgery wherever required. Diazepam because of its long action, requiring more intense monitoring has slowly fallen out of favour from many places.
- Alprazolam continues to be helpful drug to be given overnight when there are no contraindications to the drug as anxiolytic promoting goodnight sleep prior to surgery.
- It is important to note that they might have abuse potential (at least some class of this drug and should be carefully monitored)
- Relative contraindication to this premedication group of drug is
  - Extreme of age groups (say more than 60 and infants).
  - Patient already having decreased level of consciousness.
  - Patients with intracranial pathology.
  - Patients in shock or significant hypovolemia.
  - Patients with anticipated difficult airway especially if monitoring and immediate management for difficult airway is not easily feasible if the patient has respiratory depression or tongue fall because of sedation – leading to a chance of potential respiratory arrest / cardiopulmonary arrest. This is true if used in non-monitored settings along with other similar group of drugs like opioids.

## Diazepam:

- Long acting sedative – metabolites are also active.
- Causes anterograde amnesia and hypnosis.
- Dose: Given in the increments of 2-2.5 mg IV till the desired effect is achieved.
- Side effects:
  - Painful on injection – give in a running drip.
  - May cause respiratory depression.
  - In hypovolemic patients can cause hypotension.
  - Effects remain for longer duration so there might be problems with breast feeding.
  - Diazepam is secreted in the breast milk.
  - Crosses placental barrier.
  - Risk of neonatal respiratory depression.
  - Decreases APGAR SCORE.
  - Can cause hypotonia in new-born.

### Midazolam:

- Three times more potent than diazepam.
- Short acting.
- Not always needed as mentioned above.
- It is significantly helpful to decrease the hallucination and agitation at times associated with ketamine Anaesthesia and is commonly used before ketamine is being administered.
- Dose: It should be given in the increments of 1 mg upwards in limited resource setting, preferably IV in adults 1mg to 2mg suffices. Midazolam must be individualised for dosing. Never give a higher dose at the start only without titrating.
- Midazolam comes as 1mg / ml dilution or as vial of 5mg / ml. It is important to recognise this difference and then use the drug appropriately.
- Midazolam crosses placenta. Though the effects are not very clear with short doses, it should be preferably avoided at least prior to the delivery of baby.
- It is secreted in breast milk. The significant of small dose of midazolam given to mother and subsequent effects on neonates in breast milk is not very clear, caution should be exercised when giving the drug to mother and should be given when absolutely necessary and not as routine premedication. Need to watch for respiratory depression and neonate sedation effect if any.

### Flumazenil:

- Benzodiazepine antagonist.
- For use in the reversal of neonatal/maternal respiratory depression.
- Dose: Incremental doses of 0.2 mg every minute till the desired effects are achieved. (Maximum dose: 1 mg total at any one time; no more than 3 mg in any one hour).
- Watch for sympathetic stimulation during the use of the drug.

### Antacids/Antiemetic's/ Prokinetics:

- These are the drugs given for reducing the acidity of gastric contents and prevention or suppression of vomiting. They either reduce the emetic effects of anaesthetic agents, surgical stimuli or they hasten the gastrointestinal motility for faster clearing.
- Over a period of time, the uniform nausea vomiting prophylaxis has been changed to specific population targeted guideline in Anaesthesia either based on the type of surgery (for e.g. ENT surgeries) or based on the patient population (e.g. female sex).
- It is estimated that around one third of patients undergoing General Anaesthesia with inhalational agents or opioids as components of the balanced Anaesthesia will experience post-operative nausea and vomiting.
- Aspiration prophylaxis is important in perioperative patients, especially obstetric labour patients. For labouring patients, following can be considered
  - Oral clear fluids and fasting times
  - Solid meals and fasting times
  - Antacids and antiemetic (including Prokinetics)
- Oral clear fluids and fasting times: uncomplicated patients who will be undergoing elective planned procedure (say LSCS) traditionally have been kept fast for 6 to 8 hours. However mild to

moderate amounts of clear fluids (and nothing else) can be given up to 2 hours prior to surgery as it is shown that it might lead to decrease the nausea and vomiting postoperative without increasing the risk of aspiration.

- Solid food should be avoided in labouring patients (almost 8 hours' nil by mouth for oily food products)
- Drugs:
- Non particulate antacids, H<sub>2</sub> blockers (recent ban on H<sub>2</sub> blocker Ranitidine should be noted) and / or metoclopramide should be timely administered to patients undergoing LSCS. IV Famotidine / IV pantoprazole is a suitable alternative to be used.

#### Promethazine:

- Not very commonly used.
- H<sub>1</sub> antihistaminic.
- Useful in motion sickness, morning sickness, postoperative vomiting.
- Duration of action 4-6 hrs.
- Side effects:
- Sedation and dryness of mouth
- By its central anticholinergic action, it blocks the extrapyramidal side effects of metoclopramide while supplementing its antiemetic actions.

#### Metoclopramide:

- Prokinetic - Introduced as a gastric hurrying agent.
- Actions:
  - GIT: Increases gastric peristalsis while releasing the pylorus and first part of duodenum speeds gastric emptying.
  - Lower oesophageal sphincter tone is increased and gastro- oesophageal reflux is prevented.
  - Should not be given with atropine. If atropine is being administered during injection, it counters the effect of Metoclopramide on Oesophageal and gastric sphincter.
- Dose: 0.15-0.2 mg/kg IV/IM.
- Adverse effects:
  - Sedation, dizziness
  - Extra pyramidal side effects

#### Ondansetron:

- 5 HT<sub>3</sub> antagonist.
- Very potent central antiemetic.
- Dose: 4-8 mg IV slowly.
- Side effects: Headache, mild abdominal discomfort.

#### Ranitidine:

- Most commonly used H<sub>2</sub> blocker. Recent ban on ranitidine has been introduced because of excess

amount of NMDA substance associated with carcinogenesis is found in the drug.

- Reduces the gastric acid secretion.
- Dose:
  - Oral–150 mg bd.
  - IV– 50 mg slowly.
- Proton Pump Inhibitors like Pantoprazole can be given in dosage of 40 mg I.V. and Rabeprazole 20 mg I.V.

#### Sodium citrate:

- Water soluble.
- Non particulate antacid
- Acts instantaneously, but duration is short.
- A potent acid neutralizer–1 gm neutralises 10 mEq HCl.
- Adverse effect:
  - Increases sodium load: May worsen CHF.
- Dose: 30 ml, 0.3 Molar solution, 30 minutes before induction.

#### Anticholinergic Agents:

- Anticholinergics as routine premedication was a common concept in the older times, but its role during recent times has been debated:
  - with the advent of modern faster acting agents which produces less secretions.
  - as well as the use of balanced Anaesthesia with strong analgesic component.
- They are used to prevent secretions (anti-sialagogue effects), prevent vaso-vagal or reflex bradycardia (especially in paediatric population where vagal system is dominating system).
- Atropine, scopolamine and Glycopyrrolate are the class of drugs. Atropine and Glycopyrrolate have been used maximum. Atropine's use has considerably (and rightly so) decreased with the advent of a more modest drug – glycopyrrolate which doesn't have extreme effect on heart rate and at time blood pressure like atropine does.
- They are also useful (glycopyrrolate being more commonly used now) in reversal preparation along with neostigmine (to reverse the effects of non-depolarising agents).

#### Atropine:

- Tertiary amine structure.
- Can cross Blood brain barrier, Placenta (May cause mild postoperative memory deficits).
- Uses:
  - As Anti-sialagogue (10-20mcg/kg I.V/I.M),
  - Treatment of reflex-mediated Bradycardia (20-70 mcg/kg I.V).
- Precautions:
  - Narrow angle glaucoma,
  - Prostatic hypertrophy,



- Coronary artery disease.
- Not a preferred premedication drug because of propensity for severe anticholinergic activity on heart (Excessive tachycardia and hypertension) and also because of safer agent availability as mentioned above.

#### Glycopyrrolate:

- Preferred Anticholinergic agent for premedication (Prevents muscarinic actions of Acetylcholine).
- Quaternary ammonium compound.
- Does not cross Placenta and Blood brain barrier.
- Causes less Tachycardia than Atropine.
- Normal dose in Adults is 0.2mg IV as single dose.

### KEY LEARNING POINTS

- Premedication remains an important component of balanced Anaesthesia
- The main aim of premedication is to help decrease the adverse effects associated with the surgery and anaesthetic agents as well as to help decrease the anaesthetic induction or maintenance agents by acting as supplement in a desired area of action.
- Though in older times the administration of all the premedication components was a routine norm rather than exception, with the advent of newer drugs and techniques individualised premedication should be planned according to type of surgery, patient population and the anaesthetic agent and technique being used.
- Appropriate monitoring, knowing the pharmacology of the drugs used in this is important.
- Sedation (benzodiazepine) as routine in LSCS should be avoided and used only when required. Midazolam crosses placentas as well is secreted in breast milk, though this varies with the drug dosage and other conditions. The clinical significance is also not always uniform or predictable.
- Aspiration prophylaxis by modifying the fasting guidelines behaviour as well as use of antacids (enteral and parenteral) and antiemetic are useful in pregnant patients undergoing LSCS or other planned procedure.
- Anticholinergics though are not routinely used now a day in recent modern practice, they form an important component in terms of anti-sialagogue effect as well as to prevent reflex bradycardia. Glycopyrrolate is preferred over atropine because of its modest effect on cardiovascular system. Contraindications should be looked out for especially in heart disease patients.

### CHECK YOUR PROGRESS

- What is the concept of premedication? What are the goals of premeditations?
- Write a short note on use of anxiolytics and sedatives with emphasis on midazolam in relation to a parturient planned for LSCS.
- Write short note on aspiration prophylaxis in parturient planned for LSCS.
- Anticholinergics and its effect during Anaesthesia. Compare Atropine and Glycopyrrolate.



# Week 6 - Module

## Premedication, Fluids, Blood & CPR



# 20

## Cardio Pulmonary Resuscitation including Obstetric CPR

### INTRODUCTION:

- Cardiopulmonary Resuscitation is an important medical procedure performed in emergency to restart a heart which has stopped beating
- From mouth to mouth breathing – bellows breathing – open heart massage to closed chest compressions, use of airway adjuncts and early use of defibrillators CPR history is fascinating as it has evolved over last 3 centuries.
- Identifying the cardiac arrest at the earliest and performing CPR by the bystanders at the earliest while expert team arrives on the scene has shown to increase the survival by almost 2 to 3 times.
- Obstetric CPR is furthermore challenging. Though there are certain differences in the obstetric CPR (especially full- term pregnant patients), the basics of CPR more or less remain same. More important is, to appreciate that there are 2 lives at stake: Mother and the child.

### LEARNING OBJECTIVES:

Learning Objective	Knowledge	Skills
Importance of CPR Physiological basis for CPR steps and Adult chain of survival	✓	Learn the CPR in simulation lab in the department on CPR mannequins. Assessment of CPR skills with emphasis on correct steps, correct technique will be done with remediation of the candidate till he or she is proficient with CPR skills
Basic Life support and advanced / comprehensive cardiac life support steps and techniques	✓	
CPR in pregnancy: Similarity and differences with the adult CPR	✓	

## WHAT IS CARDIAC ARREST?

- Cardiac Arrest is defined as “Sudden cessation of Cardiac Mechanical Activity”.
- It results in cessation of blood supply and oxygen to body organs.
- If not managed adequately & rapidly – i.e in a timely fashion, may lead to death or Hypoxia to significant organs (brain & others) with significant morbidity.
- Cardiopulmonary Resuscitation (CPR) is symptomatic treatment, aimed at sustaining vital organ function till spontaneous cardiac function is restored. However, the search for a reversible cause of arrest is essential. Cardiac arrest is defined as an apnoeic, unresponsive and unconscious patient with absent central pulses. The cerebral ATP stores get depleted within 4-8 minutes of arrest.

### Epidemiology:

- Sudden cardiac arrest remains a leading cause of death worldwide.
- Cardiac arrest can occur out of hospital (OHCA) as well as in Hospital (IHCA).
- Outcome from OHCA remains poor with approximately 11% of non-traumatic cardiac arrest patient who have received CPR survive to hospital discharge.
- In hospital, cardiac arrest have better outcome with approximately 25% of adults surviving to discharge.
- Best outcomes are seen when CPR is commenced at the earliest. When effective resuscitation efforts are instituted rapidly, backed up by an efficient medical emergency response system, initial resuscitation rates of about 40% and survival to hospital discharge of 10-15 % are reported.
- To further improve these survival number, it is essential that the CPR training is given appropriately to public, emergency services personnel and of course those who work in the clinical care of the patient. These are given through various societies across the globe through their national resuscitation councils or clinical societies training programme. This is through the development and updating of the CPR guidelines done at regular interval by them.

### Chain of survival: (Figure 1)

- These are pictorial depiction of series of coordinated and interlinked actions, all of which when performed in proper sequence and by a team which is well trained to perform them will result in higher chances of survival.
- In simple terms, it summarises the whole concept of CPR
  - There are 2 separate chain of survivals for in hospital (IHCA) and out of hospital cardiac arrest (OHCA) with minor differences as follows.

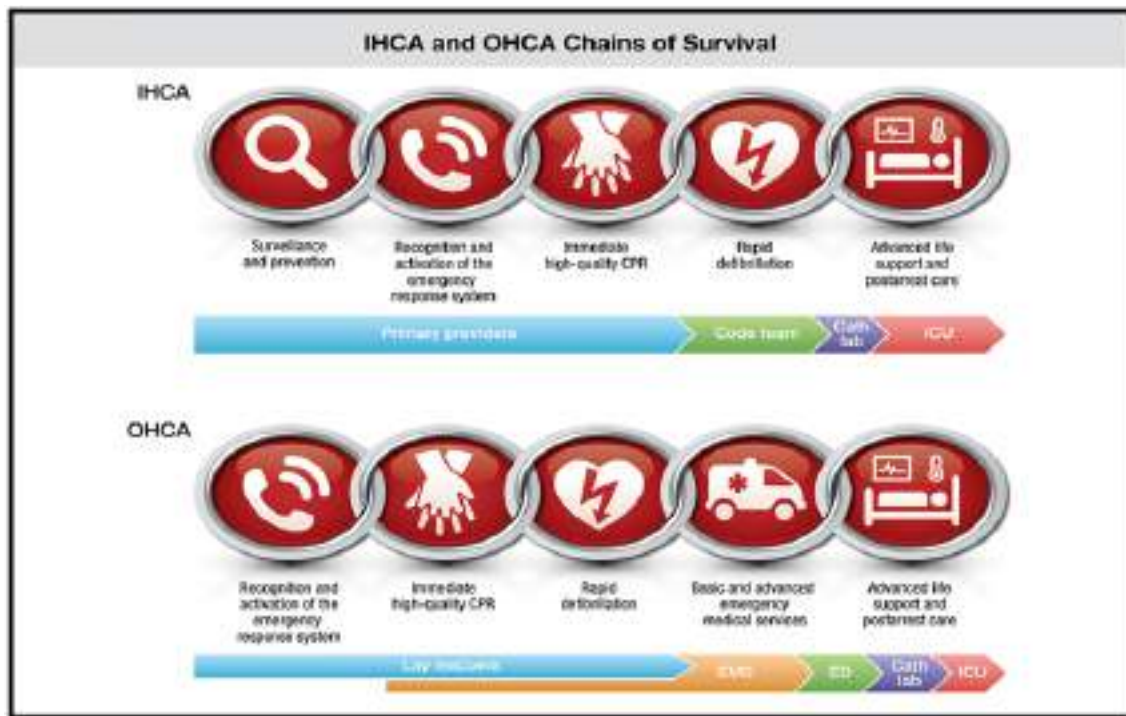


Figure 1: Chain of survival (OHCA and IHCA)

### CPR Guidelines:

- There are many guidelines available for teaching and training in CPR like AHA (American heart association), European Societies, Indian Resuscitation council as well as government bodies promoting these guidelines training in their authority as feasible.
- They work in liaison within the umbrella body of ILCOR i.e. International Liaison committee on Resuscitation.
- The essential components of CPR range from identifying an unresponsive patient, calling for help to doing advance manoeuvres like intubation, drug therapy, peri-mortem caesarean section and so on. This various skill can be grouped together into 3 basic components guidelines which basically will be along the continuation of spectrum of clinical care when a patient who needs CPR is identified and treatment started.
- The crux of a good CPR is high quality CPR performed by an excellently trained members of team working together with all the qualities of a good team work following the uptodate evidence based guidelines for doing the CPR.
- These are essentially grouped into 3 categories (previously only 2) as following based on the expertise of the skill required, resources required in terms of equipment and human resources required.

### Chest compression only CPR /Hands only CPR

- This is the latest entry in the spectrum of CPR guidelines. It forms the very much the base of initiating a CPR at the patient's side even by the bystander without any equipment or resources available
- This re-emphasises the concept that out of all the components of CPR, a high-quality chest compression is probably the most important step.
- Traditionally the CPR (as the name also suggests) always had emphasis on chest compression



and initiating some form of ventilation assistance (mouth to mouth, barrier device) as initial components of CPR steps while advance caregivers were on the way.

- It was noted that while this was helpful, many a times by-standers didn't initiate the CPR for fear of "giving mouth to mouth breathing" or "difficulty in remembering the exact steps of CPR with skills for ventilation".
- Scientific evidence shows better outcomes when at least (ONLY) chest compressions are given in the initial few minutes after cardiac arrest is diagnosed as compared to doing nothing and waiting for the trained personnel with resources to arrive at the scene and start CPR. So, over a period of last few years, increased emphasis has been given on chest compression only CPR training for lay persons at least so that some form of scientifically valid help is given immediately in the "crucial initial few minutes" after the cardiac arrest
- Traditionally the components of Hands only CPR are:
  - Scene safety
  - Identifying unresponsive patient
  - Calling the "local medical emergency help" number
  - Starting chest compressions only CPR in the desired sequence of 30 compressions of 5 cycles without interrupting for ventilation. After 5 cycles checking for signs of life (repeating the above) and if no signs continuing the hands only CPR till BLS / ACLS team arrives or till the personnel feels that the efforts are futile or he or she is unable to do it further.
  - Also since this is basically designed for layperson, most guidelines do not recommend checking pulse or respiration as step before starting compressions
  - This can be easily and appropriately converted to the next step in the spectrum of CPR guidelines i.e. Basic life support whenever the necessary trained team with required equipment arrive at the scene.

## Basic Life Support

- This is the next spectrum of group of clinical actions performed in a coordinated way till further advanced care team takes over.
- This has been always at the forefront as minimum required training standard applicable to all the healthcare personnel working in clinical care area.
- Building over the hands only compression, a trained personnel can take handover and give BLS (can also take the help of bystander if they are trained).
- BLS involves high quality chest compressions, early defibrillation and intermittent coordinated artificial breathing (generally through proper airway gadget).
- The sequence in nut shell can be summarized as:
  - Scene Safety.
  - Identification of unresponsive patient.
  - Calling for early help (manpower and equipment).
  - Checking for carotid pulse and respiration.
  - Initial of high quality CPR (details later).
  - Early defibrillation.
  - Continue BLS till ACLS team arrives or efforts deemed futile as by the team.



## Advanced Cardiac Life support

- Advanced or comprehensive (different names with mild differences) cardiac life support essentially is group of actions performed in continuation (rather than continuation, they are performed along with) BLS by team of trained health care [personnel which requires intervention other than BLS in form of:
  - Advanced airway manoeuvres.
  - Drugs.
  - Reversible causes identification and their corrections as feasible.
  - Any other advanced method required to bring back the life.
  - Post resuscitative measures to sustain life and decrease the side effects associated with cardiac arrest.

As seen before also, before CPR is commenced its equally important to identify cardiac arrest.

### Diagnosis:

#### Clinical (Constellation of Signs and Symptoms)

- Unresponsiveness.
- Absent carotid pulse.
- Apnoea or Erratic / Gasping breathing.

#### Monitoring:

- ECG: Asystole / PEA / Pulseless VT / Ventricular Fibrillation. Intra-operatively (Might help along with above findings):
- NIBP / IBP: BP not recordable.
- SpO<sub>2</sub> trace not recordable
- EtCO<sub>2</sub>: Not recordable.

Now let us see Basic and Advanced or Comprehensive Cardiac life support algorithms – guidelines in detail.

### Basic Life Support:

- Basic life support refers to the elements of CPR, which essentially comprises airway management, breathing and chest compression along with the early defibrillation.
- The sequence of chest compressions first followed by Airway and Breathing management – The “C-A-B sequence” of CPR has been the major change in BLS guidelines in 2010 over the previously followed “A-B-C sequence”
- Basic steps of BLS or Basic life support are as follows: (Figure 3 and 4)
  - C: Chest compression
  - A: Airway
  - B: Breathing
  - D: Defibrillation: (Integral part of BLS since year 2000)
- Approach to an unconscious patient

1. Ensure scene safety.
2. Check responsiveness by tapping the patient preferably on both the shoulders and shouting “are you alright?”. Look for response in terms of significant movement, any verbalization attempt on patient’s part.
3. If the patient is deemed unresponsive, ask person with you to **call for help**. Out of Hospital, one can call the helpline numbers available in the geographical area 108 and inform them about the location, number of patient(s), their clinical condition so that they can send ALS ambulance. It is important to have closed loop communication with the 108 team on phone to see to it that they understand the message clearly.

For in hospital cardiac arrest, it is advisable to have **code blue teams** and activate the code blue teams with the exact location of the patient, till one starts basic Life support / supportive measures as needed.

It is important that one “requests” for AED or manual defibrillator along with crash cart to be brought to the patient’s bedside by the person helping you.

#### 4. Pulse and respiration check:

(Central) Carotid pulse is checked by palpating Neck of the patient.. Watch the patient if has regular or gasping or absent breathing.

This pulse checks and respiration check is done simultaneously and should be done for a minimum of 5 seconds and not more than 10 seconds.

The combination of the above three evaluations in an unresponsive patient will give you three possible scenarios:

- a. Unresponsive, Pulse present, respiration present:
  - eg: CNS diseases, Vasovagal, Syncope, Hypoglycaemia, poisoning
- b. Unresponsive, pulse present but absent / gasping respiration: (Respiratory arrest)
  - e.g. poisoning Opioids overdose, posterior circulation stroke.

Here respiratory support is needed (artificial breathing) and pulse check done either continuously or every 2 minutes to see that the patient has not gone into cardiac arrest while one treats the respiratory arrest.

- c. Unresponsive, pulse absent and absent or Gasping respiration: Cardiac arrest.  
Immediate BLS / BCLS needs to be started while the advanced team is summoned for help.

#### 5. Begin “High quality chest compressions” with ventilation as follows

- a. Hand position: 2 finger breath above the sternal notch in the midline. Palms interlocked with each other. Elbows straight while you are leaning over the patient allowing good depth of compression as well as complete chest recoil
- b. Rate: 100 to 120 / minute
- c. Ratio: 30 compressions and 2 ventilations with AMBU bag
- d. Depth: 5 cm minimum, maximum 6cm
- e. Allow complete chest recoil

- f. Minimum interruptions in chest compression

## 6. Defibrillation

- a. As soon as the defibrillator (Manual or AED) arrives, the person trained in using the AED or defibrillator, who is part of the BLS team attaches the disposable pads on chest as shown in the picture on the pad (for AED) or chest leads (for manual defibrillator). The chest compressions and the ventilation continue while the pads / chest leads are attached.
- b. The normal position for AED pads (same as for giving shock by manual defibrillator): under the right clavicle and in the left chest at apical position of the heart.
- c. The CPR cycle is only interrupted when the AED is ready to analyse (or in manual defibrillator when the ECG leads have been attached)
- d. Once the rhythm is identified as shockable (auto analysed by AED, manually will have to diagnose in Manual defibrillator), then shock must be delivered.
- e. In AED, the charging to the set joules as per the latest guidelines is done by the machine itself whereas in manual defibrillator 120 – 200 J escalating shock is given for defibrillation.
- f. It is very important that the person who is going to give shock announces it and visually sees that no one is touching the patient or the bed and the oxygen is kept away from the patient when the shock is delivered.

## 7. Resume CPR.

- a. CPR is resumed immediately after shock is delivered till 2 minutes.
- b. Only after this 2 minute of CPR is done, reanalysis is done with the combination of monitor, pulse check or any signs of life if Return of spontaneous circulation (ROSC) has been achieved or if the patient still continues to be in cardiac arrest. This 5 – 10 second interval is also used to assess whether the cardiac arrest ECG rhythm is shockable or non-shockable).

## Early Defibrillation (use of AED / Manual Defibrillator) (Figure 2)

- As noted above the ECG pattern of cardiac arrest shows 4 different types of rhythms i.e. Ventricular fibrillation, Ventricular tachycardia, Pulseless electrical activity and Asystole.
- Of these, the ventricular Fibrillation (V. Fib) and Ventricular Tachycardia (V. Tach) are termed as shockable rhythms and are seen early after cardiac arrest. They are amenable to treatment with D.C Shock defibrillation treatment and pharmacologic antiarrhythmic therapy with Amiodarone and Lidocaine.
- It is imperative that they are diagnosed early in the course of cardiac arrest when resuscitation has been started. Another common issue is that since it requires ECG rhythm identification, it might become a hindrance. For this, there are AEDs which helps with the rhythm identification, and as per the algorithm, the machine itself decides whether the rhythm is shockable or not.
- If the rhythm is shockable, the AED will begin to charge it as per company's pre-decided energy which is in accordance to the latest guidelines and will indicate when the shock is ready to be delivered.
- Another advantage of AED is that it will prompt the exact steps as to how to use it once it is turned on. It thus helps operator in smooth use of AED with less errors.
- Till above steps (i.e. the rhythm identification, deciding if its shockable or non-shockable, selecting

the energy joules and lastly charging the machine), in manual defibrillation needs to be done manually by the operator.

- The last step i.e. Shock button needs to be pressed in both the machines i.e. AED / Manual defibrillator by the operator after the operator sees and gives a clear voice command that he or she is going to shock the patient. Operator also ensures to see that no one is in touch with the patient or to any material through which the shock can be passed on to the bystander. Operator also ensures that the oxygen is turned off during the electrical DC cardioversion shock.
- Once the shock is delivered, the next step is to continue the CPR immediately for 2 minutes.

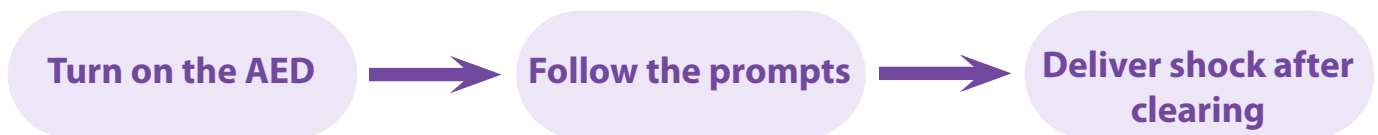


Figure 2: The procedure to use AED



Figure 3: ISA BCLS core link diagram

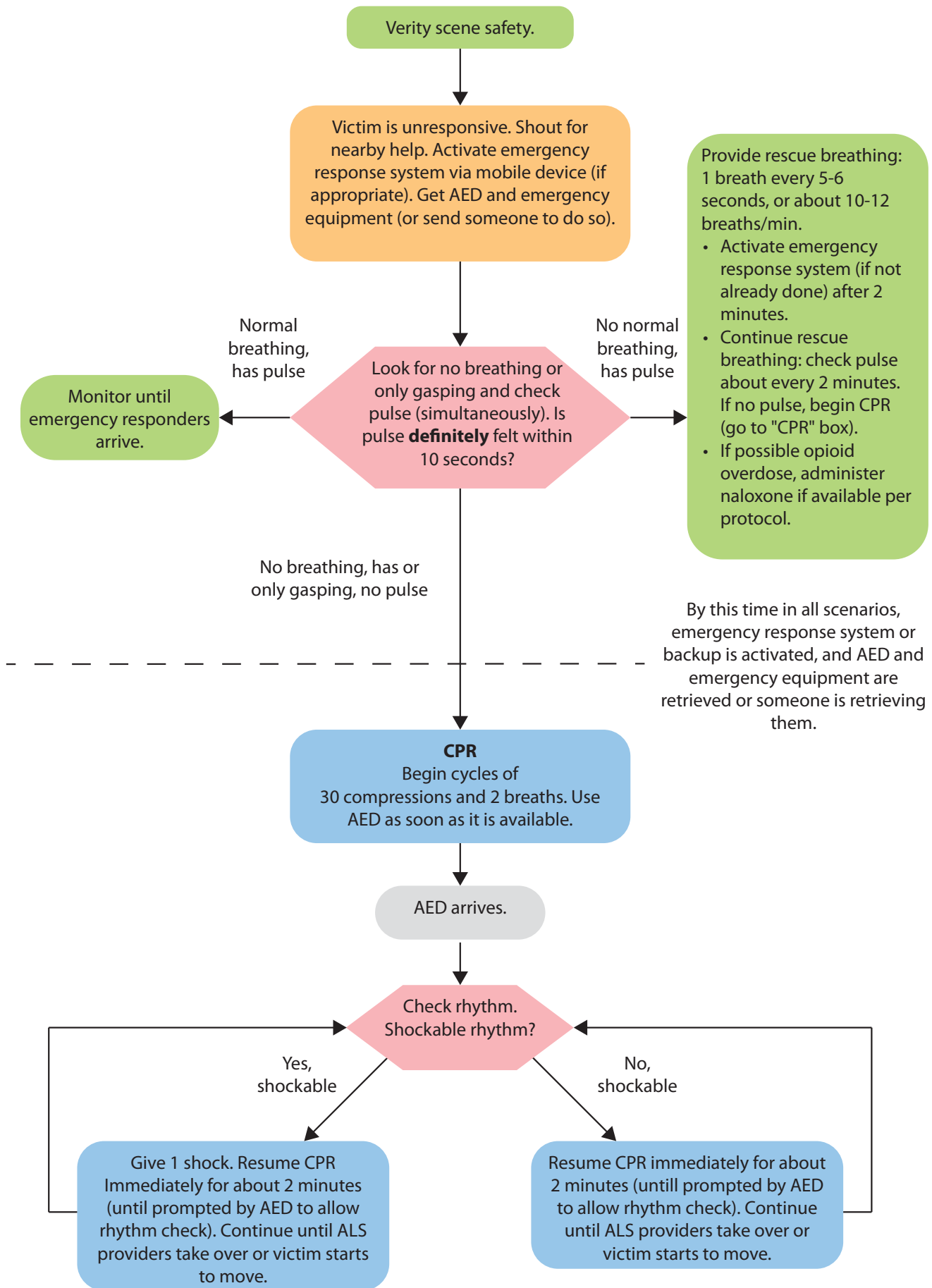


Figure 4: AHA 2015 BLS algorithm

The BLS or BCLS is continued in the above fashion in cycles till the ACLS team and help arrives.

## Airway management during CPR

- The commonest cause of airway obstruction in an unconscious patient is the tongue or epiglottis falling back upon the posterior pharyngeal wall.
- The primary method to counter this is the 'head tilt-chin lift' manoeuvre. In a scenario where cervical spine injury is a possibility, only the 'jaw thrust' is to be applied, with minimal or no movement of the head and neck.
- In Basic Life support, no advanced airway manoeuvres are taught, and basic manoeuvres as above are taught as means of making a patent airway.
- Oral airways, Supraglottic devices all can be used along with to maintain airway and breathing.
- When the expertise is available, it is desirable to obtain a definitive airway as early as possible, which includes endotracheal intubation (or rarely tracheostomy) without interrupting the chest compressions.
- Mouth to Mouth breathing or Mouth to stoma breathing as general is discouraged.

## Breathing

- After opening or establishment of a patent airway, rescue breaths are slowly administered taking two seconds per breath (inclusive of inhalation and exhalation) in appropriate combination with the chest compressions: Ventilation ratio of 30: 2.
- Chest rise is seen as an effective endpoint during BCLS.
- If these breaths are ineffective, the head and neck may need repositioning. Any obstruction by a foreign body must be relieved by removal.
- When available, a self-inflating bag-valve-mask may be used to provide more effective ventilation. Oxygen whenever available should be used with Self inflating bag to achieve a high FiO<sub>2</sub> level.
- Quantitative continuous wave capnography whenever available is best method to detect the adequacy of patency of established airway. It also helps as surrogate markers for quality of chest compressions being given, helps in identifying the return of spontaneous circulation.

## Advanced cardiac life support

- In addition to BLS skill, it includes the use of adjunctive equipment and techniques for assisting ventilation and circulation, ECG monitoring, defibrillation, establishment of i.v. access and pharmacologic therapy along with finding reversible cardiac arrest causes and treating them.
- The ACLS also includes the post Return of spontaneous circulation post ROSC) management.

## Pharmacologic Therapy

- Drug therapy is always secondary to other interventions like chest-compressions, airways management, ventilation, and defibrillation in cardiac arrest.
- The route of administration preferred is intravenous. The most rapid drug levels are achieved by administration into a central vein, however peripheral vein administration is also effective.
- It is to be noted that CPR should not be interrupted just in order to establish a central venous access. Alternatively, the intraosseous and intratracheal routes may be used for drug administration. Doses 2-2.5 times higher than the intravenous values are to be used for

intratracheal administration.

### Epinephrine

- Epinephrine acts by producing peripheral vasoconstriction by its  $\alpha$ -adrenergic properties, thus increasing the aortic diastolic pressure and coronary perfusion.
- Epinephrine remains the vasopressor of choice in CPR. The recommended standard dose is 1 mg i.v, repeated as required every 3-5 minutes.

### Amiodarone

- It is a complex drug with sodium calcium potassium and adrenergic blocking properties. In cardiac arrest, it is indicated in Shockable cardiac arrest rhythms i.e. Ventricular fibrillation and Pulseless ventricular tachycardia.
  - Dose: first dose 300 mg i.v / i.o (Intraosseous).
  - Second dose 150 mg i.v / i.o.

(Lidocaine can also be used in shockable rhythms if Amiodarone not available).

Other drugs as required in emergency to treat the reversible causes of cardiac arrest would be Sodium bicarbonate, Calcium gluconate, KCl injection, Magnesium sulphate, Noradrenaline, IV fluids, Dextrose fluid which are all stored in the crash cart.

### Post "Return of spontaneous circulation"(ROSC) care:

- During a successful resuscitation attempt one achieves a return of spontaneous circulation i.e. the heart doesn't need outside compressions to effectively produce a stroke volume and therefore a cardiac output, but starts beating by itself again.
- However, there are very high chances that if appropriate and timely interventions are not done (specially to treat the reversible causes of cardiac arrest), the patient may land up in cardiac arrest again.
- Also, it is expected that during the time the heart wasn't beating or was not beating appropriately because of the external compressions, there must have been tissue hypoperfusion and hypoxia which can cause subsequent injury to the organs. The secondary effects need to be prevented (especially for the brain where the effects may be irreversible)
- For this, a equal and important component of chain of survival is "post ROSC" care.
- It can be approached in "ABCD" fashion like any other emergency.
- Another important concept here is "Targeted temperature management" – i.e. inducing hypothermia (wherever not contraindicated) and avoiding fever for the initial 48 to 72 hours to prevent the effects of reperfusion injury.
- The patient should be cared in an intensive care setting, with all appropriate search done to find out the reversible causes and treat them expeditiously.

### Team Work:

- Advanced life support management is also about having a good team work with all the important qualities of a good team.
- A good team leader who leads the team should know the weakness and strengths of his team.



The team should follow other dynamics meticulously like constructive criticism, mutual respect, closed loop communication, debriefing at every CPR conducted

- Ideally for an ACLS 6 persons are ideally required to carry out the following task effectively
  1. Airway management.
  2. Chest compressions.
  3. Monitor and Defibrillations.
  4. IV line, drug therapy.
  5. Record keeping.
  6. Team leader

### Documentation and Audit:

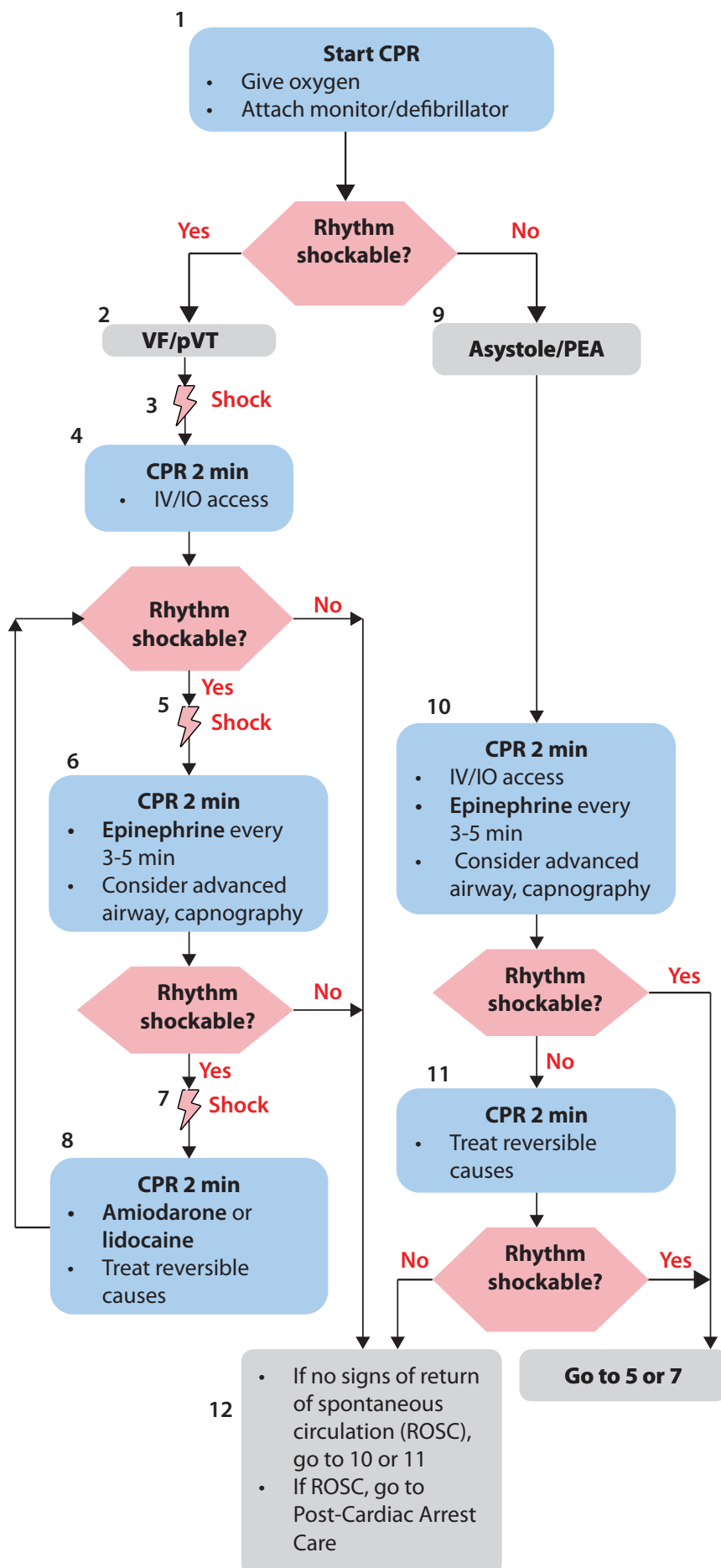
- Whenever a CPR call is attended, it should be documented appropriately. It has a medicolegal value as well as helps for internal quality and safety audits.
- The timing of onset of cardiac arrest, initial presenting rhythm, team activation, interventions done, reversible causes tried to ascertain and procedures done to reverse them, Total time of CPR given, outcome - ROSC or death, post ROSC care, relatives counselled – all need to be documented in a time line frame.
- This can be used to do monthly audits / death meets to see how the process can be improved further.

### High Quality CPR Components:

- Minimise interruption in between chest compressions.
- Compression rate 100 - 120 / minute.
- Compression rate 5 - 6 cm.
- Allow complete chest recoil.
- No excessive ventilation.

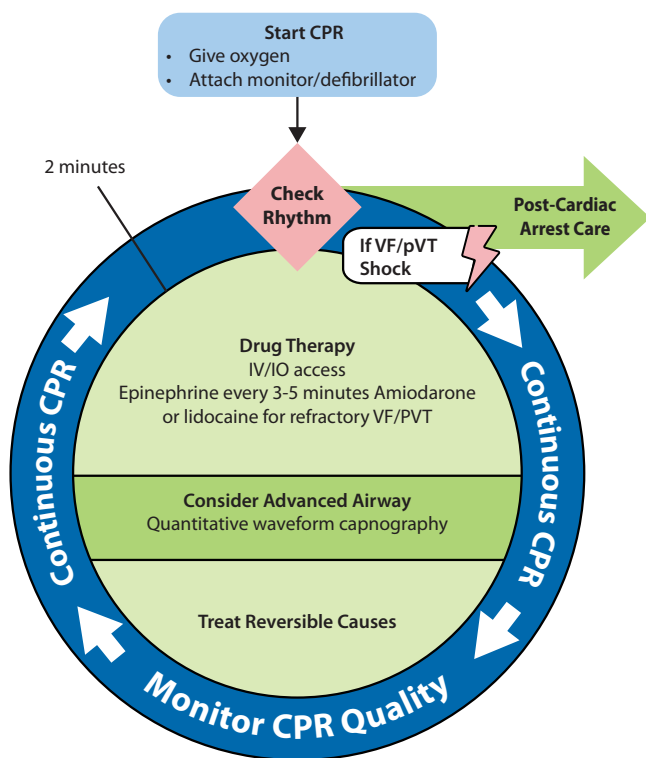


Figure 5: ISA Comprehensive Cardiac Life support core links



CPR Quality
<ul style="list-style-type: none"> <li>• Push hard (at least 2 inches [5 cm]) and fast (100-120/min) and allow complete chest recoil.</li> <li>• Minimize interruptions in compressions.</li> <li>• Avoid excessive ventilation. • Change compressor every 2 minutes, or sooner if fatigued.</li> <li>• If no advanced airway, 30:2 compression-ventilation ratio.</li> <li>• Quantitative waveform capnography               <ul style="list-style-type: none"> <li>- If Perco, &lt;10 mm Hg, attempt to improve CPR quality.</li> </ul> </li> <li>• Intra-arterial pressure               <ul style="list-style-type: none"> <li>- If relaxation phase (dia-stolic) pressure &lt;&lt;20 mm Hg, attempt to improve CPR quality.</li> </ul> </li> </ul>
Shock Energy for Defibrillation
<ul style="list-style-type: none"> <li>• <b>Biphasic:</b> Manufacturer recommendation (eg, initial dose of 120-200 J); if unknown, use maximum available. Second and subsequent doses should be equivalent, and higher doses may be considered.</li> <li>• <b>Monophasic:</b> 360 J</li> </ul>
Drug Therapy
<ul style="list-style-type: none"> <li>• <b>Epinephrine IV/IO dose:</b> 1 mg every 3-5 minutes</li> <li>• <b>Amiodarone IV/IO dose:</b> First dose: 300 mg bolus. Second dose: 150 mg. -OR-</li> <li>• <b>Lidocaine IV/IO dose:</b> First dose: 1-1.5 mg/kg. Second dose: 0.5-0.75 mg/kg.</li> </ul>
Advanced Airway
<ul style="list-style-type: none"> <li>• Endotracheal intubation or supraglottic advanced airway</li> <li>• Waveform capnography or capnometry to confirm and monitor ET tube placement</li> <li>• Once advanced airway in place, give 1 breath every 6 seconds (10 breaths/min) with continuous chest compressions</li> </ul>
Return of Spontaneous Circulation (ROSC)
<ul style="list-style-type: none"> <li>• Pulse and blood pressure</li> <li>• Abrupt sustained increase in PETCO<sub>2</sub> (typically 240 mm Hg)</li> <li>• Spontaneous arterial pressure waves with intra-arterial monitoring</li> </ul>
Reversible Causes
<ul style="list-style-type: none"> <li>• Hypovolemia</li> <li>• Hypoxia</li> <li>• Hydrogen ion (acidosis)</li> <li>• Hypo-/hyperkalemia</li> <li>• Hypothermia</li> <li>• Tension pneumothorax</li> <li>• Tamponade, cardiac</li> <li>• Toxins</li> <li>• Thrombosis, pulmonary</li> <li>• Thrombosis, coronary</li> </ul>

Figure 6: ACLS Algorithm (AHA 2018)



### CPR Quality

- Push hard (at least 2 inches [5 cm]) and fast (100-120/min) and allow complete chest recoil.
- Minimize interruptions in compressions.
- Avoid excessive ventilation.
- Change compressor every 2 minutes, or sooner if fatigued.
- If no advanced airway, 30:2 compression-ventilation ratio.
- Quantitative waveform capnography
  - If PETCO, <10 mm Hg, attempt to improve CPR quality.
- Intra-arterial pressure
  - If relaxation phase (diastolic) pressure <20 mm Hg, attempt to improve CPR quality.

### Shock Energy for Defibrillation

- **Biphasic:** Manufacturer recommendation (eg, initial dose of 120-200 J); if unknown, use maximum available. Second and subsequent doses should be equivalent, and higher doses may be considered.
- **Monophasic:** 360 J

### Drug Therapy

- **Epinephrine IV/IO dose:** 1 mg every 3-5 minutes
  - **Amiodarone IV/IO dose:** First dose: 300 mg bolus. Second dose: 150 mg.
- OR-
- **Lidocaine IV/IO dose:** First dose: 1-1.5 mg/kg. Second dose: 0.5-0.75 mg/kg.

### Advanced Airway

- Endotracheal intubation or supraglottic advanced airway
- Waveform capnography or capnometry to confirm and monitor ET tube placement
- Once advanced airway in place, give 1 breath every 6 seconds (10 breaths/min) with continuous chest compressions

### Return of Spontaneous Circulation (ROSC)

- Pulse and blood pressure
- Abrupt sustained increase in PETCO, (typically 240 mm Hg)
- Spontaneous arterial pressure waves with intra-arterial monitoring

### Reversible Causes

- |                           |                         |
|---------------------------|-------------------------|
| • Hypovolemia             | • Tension pneumothorax  |
| • Hypoxia                 | • Tamponade, cardiac    |
| • Hydrogen ion (acidosis) | • Toxins                |
| • Hypo-/hyperkalemia      | • Thrombosis, pulmonary |
| • Hypothermia             | • Thrombosis, coronary  |

Figure 7: ACLS Algorithm 2018

## CPR in pregnant patient:

- CPR in pregnancy brings challenging times not only for the patient and family but for the entire healthcare workers involved in the care. More so because two lives are at stake and because pregnancy is further associated with a stronger emotional component.
- Successful resuscitation of a pregnant woman and survival of the foetus require prompt and co-ordinated high quality CPR with some modifications in Advanced Cardiac Life Support (ACLS).
- BLS and ACLS for Pregnant Patient involves Multi-disciplinary approach.
- BLS in obstetric patient should have more members (preferably 4 members) and the hospital staff should be such trained that ideally any member of the hospital staff (Doctor or paramedic) should be able to perform the BLS duty.
- Team consists of
  - First Responder and BLS / ACLS team members
  - Anaesthesiologist
  - Obstetrician
  - Neonatologist.
- Reports suggest better outcomes in Pregnant patients CPR registry as compared to general patients.
- It is highly imperative that the team involved in this are highly motivated, trained appropriately and have appropriate equipment and resources. Even in resource limited settings, things can be modified to adapt to the local availability of the resources in best possible way.
- Let us have look at the algorithms for BLS / ACLS in pregnant patient followed by important differences and similarities in the pregnant and non-pregnant patient CPR algorithms.

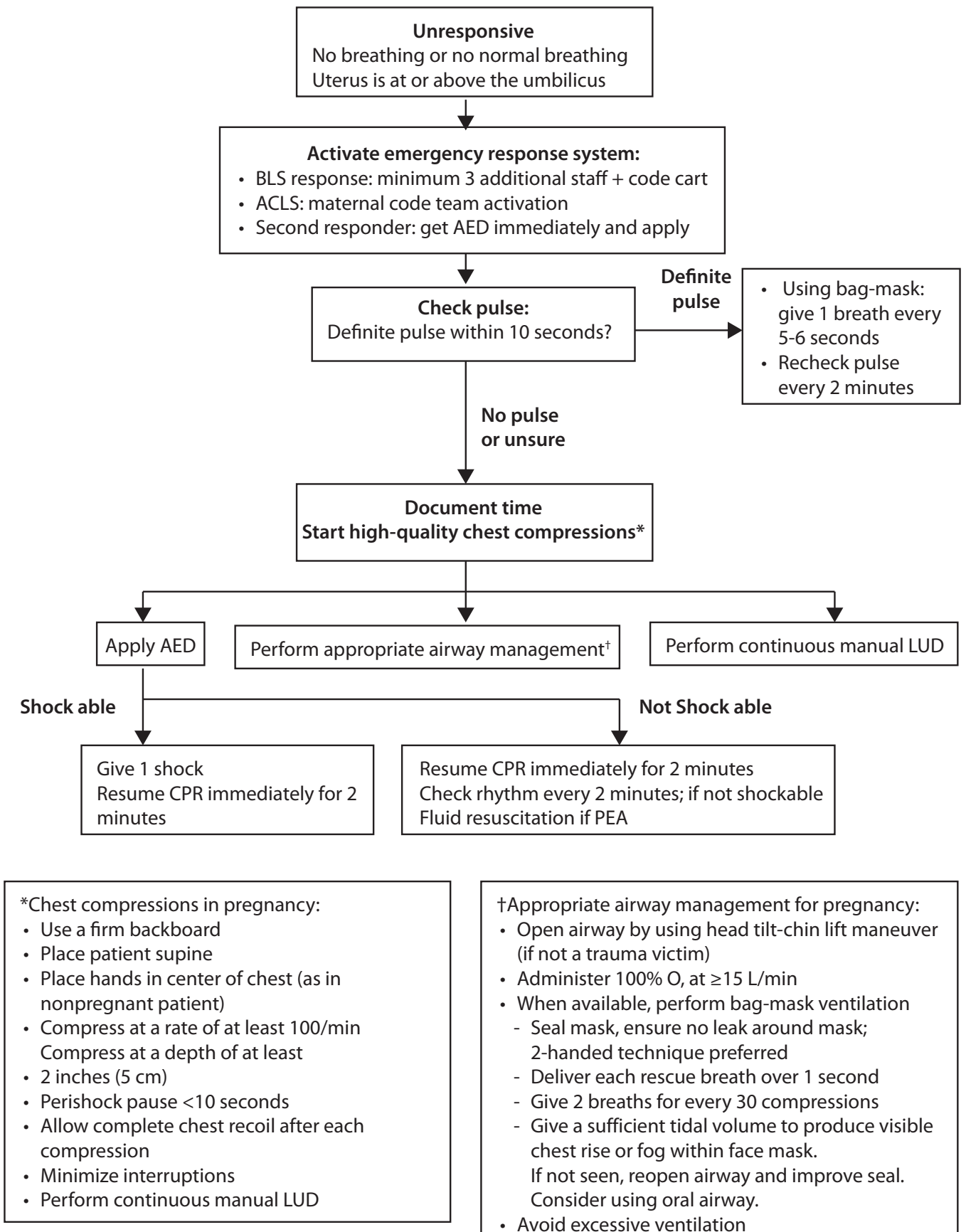


Figure 8: AHA 2015 algorithm for BLS in pregnant patient  
( Note the C-A-B-U approach)

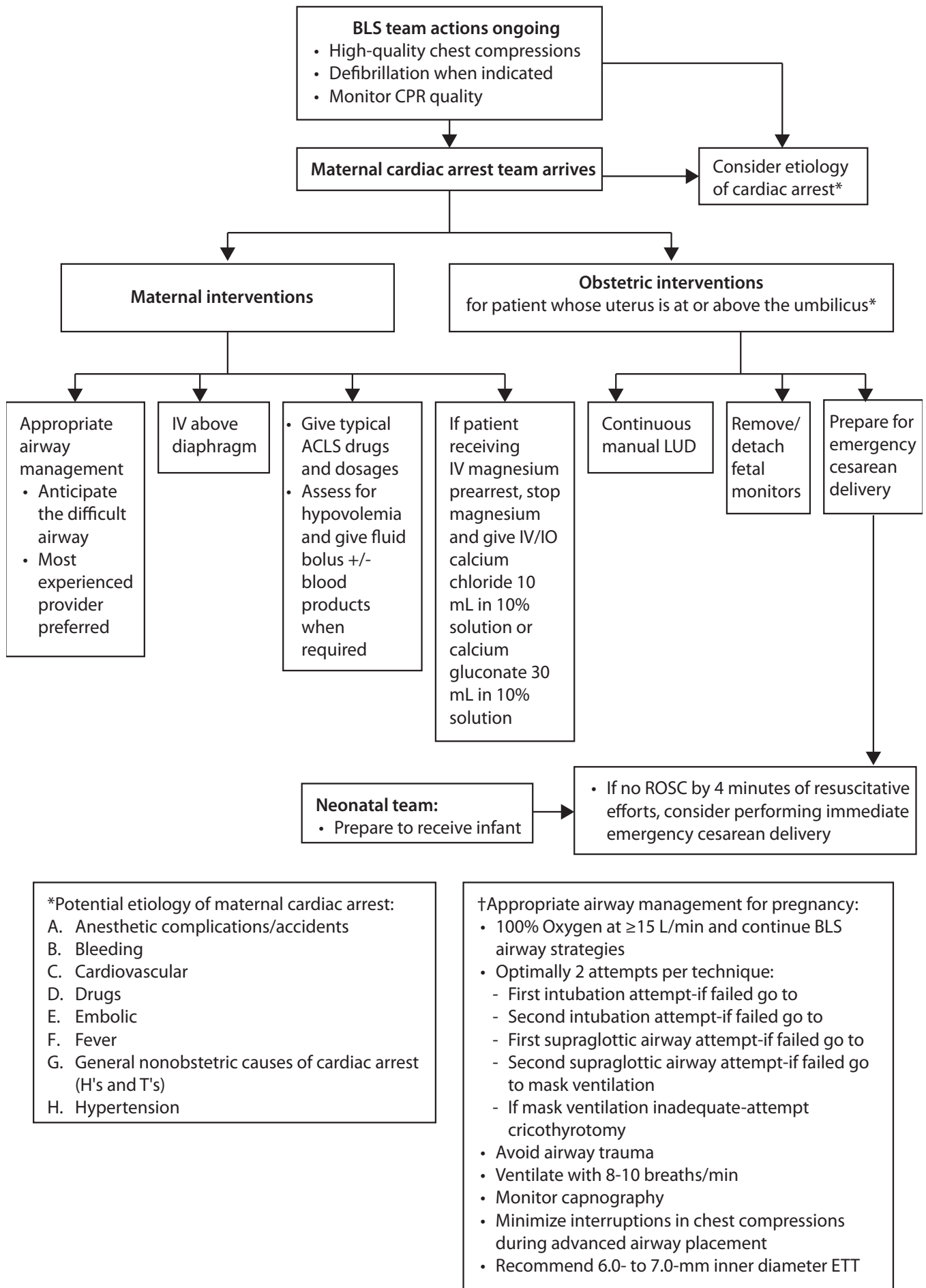


Figure 9: ACLS algorithm for Pregnant patient (AHA 2015)

**Table 1: Comparison of BLS – ACLS algorithm and steps in nonpregnant adult with pregnant patient**

Parameter / Component of CPR	Non-Pregnant patient	Pregnant Patient (Additional differences)
Prevention of Cardiac arrest	<ul style="list-style-type: none"> <li>Warning score system.</li> <li>Preparation of teams for CPR.</li> </ul>	<ul style="list-style-type: none"> <li>Modified obstetric warning scores.</li> </ul>
Pre – cardiac arrest planning	<ul style="list-style-type: none"> <li>Staff training.</li> </ul>	<ul style="list-style-type: none"> <li>Staff training.</li> <li>Facility for perimortem Caesarean section.</li> <li>New-born resuscitation planning.</li> </ul>
Team	<ul style="list-style-type: none"> <li>BLS – Ideally 2 persons.</li> <li>ACLS – Ideally 6 persons.</li> </ul>	<ul style="list-style-type: none"> <li>BLS – 4 persons ideally (Chest compression, Airway, AED, Manual LUD)</li> <li>ACLS – same</li> <li>Additional team</li> <li>Obstetrician + Assistant</li> <li>Anaesthesiologist + Nurse.</li> <li>Paediatrician + Nurse.</li> </ul>
<b>Basic Life Support</b>		
Scene safety	<ul style="list-style-type: none"> <li>Same</li> </ul>	<ul style="list-style-type: none"> <li>Same</li> </ul>
Response check	<ul style="list-style-type: none"> <li>Unresponsiveness identify.</li> </ul>	<ul style="list-style-type: none"> <li>Unresponsiveness identify.</li> <li>Note Uterus height above or at umbilicus.</li> <li>Time noticed and documented, important for perimortem caesarean section (PMCS).</li> </ul>
Activate help	<ul style="list-style-type: none"> <li>108 / Code blue.</li> </ul>	<ul style="list-style-type: none"> <li>108 / Maternal code blue.</li> </ul>
Pulse check	<ul style="list-style-type: none"> <li>Same 5 – 10 seconds.</li> </ul>	<ul style="list-style-type: none"> <li>Same 5 – 10 seconds.</li> </ul>
High Quality chest compressions	<p>Same</p> <ul style="list-style-type: none"> <li>100 – 120 / minute.</li> <li>30:2.</li> <li>5 to 6 cm depth.</li> <li>Complete recoil.</li> <li>Minimum interruptions.</li> </ul>	<p>Same and additional</p> <ul style="list-style-type: none"> <li>Hand position – middle of the sternum in full term patient.</li> <li>Firm backboard.</li> <li>Supine position only.</li> <li>Perform continuous Manual LUD.</li> </ul>
Airway and Breathing	<ul style="list-style-type: none"> <li>As normal BLS</li> <li>One hand / two hand method</li> <li>Oxygen</li> <li>30:2</li> </ul>	<ul style="list-style-type: none"> <li>As normal, however, preferred to do two handed ventilation 100% FiO<sub>2</sub> (o<sub>2</sub> at 15 litre / minute)</li> </ul>
Defibrillation	<ul style="list-style-type: none"> <li>AED / Manual Defib.</li> <li>Under right clavicle and left side apex position.</li> </ul>	<ul style="list-style-type: none"> <li>No change in dose.</li> <li>Pad position also same (be sure to attach left apex paddle under breast tissue).</li> </ul>



Parameter / Component of CPR	Non-Pregnant patient	Pregnant Patient (Additional differences)
<b>ACLS Changes</b>		
Advanced Airway	<ul style="list-style-type: none"> <li>• Bag and Mask – Supraglottic airway devices – Definitive airway.</li> </ul>	Same, except <ul style="list-style-type: none"> <li>• Anticipated difficulty.</li> <li>• Experienced Anaesthesiologist to attempt intubation.</li> <li>• Cricoid pressure cannot be routinely recommended, not if its hampering the airway patency.</li> </ul>
Drugs and IV	<ul style="list-style-type: none"> <li>• As mentioned above in ACLS rhythm.</li> <li>• (Common drugs – Adrenaline, Amiodarone, Xylocard).</li> </ul>	Same. <ul style="list-style-type: none"> <li>• No change in drug doses</li> <li>• Give additional consideration to- IV to be taken above the diaphragm to allow drug to be reached to heart easily</li> <li>• If patient was receiving Iv Magnesium pre arrest, give calcium gluconate 30ml</li> </ul>
Reversible causes	<ul style="list-style-type: none"> <li>• 5Hs and 5Ts.</li> </ul>	<ul style="list-style-type: none"> <li>• 5Hs and 5Ts.</li> <li>• ABCDEFGH obstetric specific causes (see algorithm above).</li> </ul>
Foetal considerations	<ul style="list-style-type: none"> <li>• Not applicable.</li> </ul>	<ul style="list-style-type: none"> <li>• No need for foetal monitoring assessment during ACLS.</li> <li>• Remove foetal monitors immediately as CPR starts.</li> </ul>
Perimortem Caesarean section (PMCS)	<ul style="list-style-type: none"> <li>• Not applicable.</li> </ul>	<ul style="list-style-type: none"> <li>• Consider PMCS for patient with fundal height at or above umbilicus.</li> <li>• Complex decision, staff training, resources all makes difference – but should be strongly considered whenever indicated.</li> <li>• Timing --- if ROSC not achieved within 4 minutes of starting CPR, PMCS should be considered.</li> <li>• Site: At site of cardiac arrest preferably, no need to shift to Ot (wastes time).</li> <li>• Equipment: All special preparation not needed, ideally a scalpel is good enough to start.</li> <li>• Procedure: Don't waste time on long asepsis, perform Manual LUD, Continue ACLS, Rapid delivery of baby.</li> <li>• Baby and Mother continued to be resuscitated as appropriate.</li> </ul>

### Recommended Equipment for PMCD: (As per AHA guidelines)

1. Scalpel with No. 10 blade.
2. Devers retractor.
3. Pack of sponges.
4. Needle driver.
5. Sutures and suture scissors.
6. Forceps (Toothed and Plain).

### Cardiac Arrest due to Hypermagnesemia:

- Toxicity generally observed in obstetric cases as a result of treatment of Eclampsia /Preeclampsia.
- Neurological symptoms of hypermagnesaemia include muscular weakness, ataxia, drowsiness, and confusion.
- Warning signs include altered sensorium, sluggish knee jerk reflex, hypoventilation, bradycardia and cardiac arrhythmias, which if not recognised in time may lead to cardiac arrest.
- ACLS modification for treatment of Mg+ Toxicity
- Calcium
  - Calcium Chloride [10%] 5 to 10 ml or
  - Calcium Gluconate [10%] 15 to 30 ml IV over 2 to 5 minutes.

### Cardiac Arrest Due to Local Anaesthetic Toxicity:

- Systemic toxicity of local anaesthetics can occur after administration of an excessive dose, with rapid absorption from local Anaesthesia site or rarely because of an accidental intravenous injection.
- ACLS Modification for suspected LA Toxicity should be utilised (Consider this as reversible cause)
  - 20% Intravenous Lipid Emulsion is used for this purpose.
  - Initial bolus of 1.5 ml/kg lean body mass over 1 minute IV followed by an infusion of 0.25 IL/ kg per minute for 30 to 60 minutes.
  - The bolus can be repeated once or twice as needed for persistent cardiovascular collapse; the suggested maximum total dose is 10 mL/kg over the first hour.

### Return of Spontaneous Circulation (ROSC):

- Indicators of ROSC are following:
- Clinically palpable Pulse and Blood pressure.
- Abrupt rise in PETCO<sub>2</sub> > 40 mmHg.
- Spontaneous arterial pressure waves in arterial pressure monitoring.
- Patient may or may not have responsiveness ( depends upon the premorbid condition as well as time required to achieve ROSC).

### Immediate Post-Arrest Care:

- ABC approach will be a nice approach to manage patient who has achieved ROSC. The goal of

post ROSC care is to avoid patient land up in cardiac arrest again as well as to minimise the side effects associated with cardiac arrest ( mainly the complications related to hypoxia and hypoperfusion to organs)

- If the patient is still pregnant, she ideally should be placed in the left lateral decubitus position to decrease the effects of aortocaval compression. This will have to be balanced against any interference it will cause with maintenance of airway.
- If patient is not in full left lateral tilt, manual LUD can be used continuously
- Patient should be transferred to ICU unless operation is required.
- The cause of the arrest should continue to be considered and treated accordingly.
- TTM: Targeted temperature management should be considered in pregnancy after ROSC.
- Foetal Monitoring: Should be performed throughout targeted temperature management and / or Post ROSC care. Plan for foetal delivery, if viable, should involve discussion with obstetric anaesthesiologist and Paediatrician.

#### Medical-Legal Considerations and Quality Assessment:

- Ideally all cases of cardiac arrest and maternal near miss should be reported to appropriate authorities.
- The Audits and proceedings should help further streamline the procedure including strengthening of trainings of the healthcare workers who will be potentially involved in these scenarios whenever they happen in the future.
- Appropriate documentation is important.

### KEY LEARNING POINTS

- CPR skills should be taught to all healthcare workers involved in clinical care of patient and it should have periodic training.
- It is important to appreciate the difference between “ABC approach in a critically ill patient while managing any emergency” vs “CAB approach to a cardiac arrest patient who will need CPR”
- Essentially the various interventions and skills required in the CPR process can be clubbed together to have three levels of life support interventions which can be provided to a cardiac arrest patient (depending upon the clinical skill of person and equipment available). These levels are basically continuation on the spectrum of clinical care of a cardiac arrest patient from very basic to advanced care. The nomenclature and the exact interventions / sequence of interventions used to describe these are slightly different as per the society which proposes it, but the essence remains pretty much the same. They can be broadly be described under following headings:
  - Hands only CPR / Compression only life support CPR
  - Basic (cardiac) Life support skills
  - Advanced / Comprehensive Cardiac / life support skills
- A well-trained team with qualities of a good teamwork is essential for improved outcomes.
- Earlier intervention in cardiac arrest is important to increase meaningful survival in cardiac arrest patients.
- “High Quality CPR” remains the essence of all the life support skills. It includes atleast –
  - Right position of hands: 2 finger breadth above xiphisternum

- Right Rate of compression: 100 – 120 / minute
- Right depth: 5 to 6 cms
- Right technique: Allow complete recoil
- Right sequence: minimise interruptions
- ACLS involves, BLS and appropriate team work, advanced airway & other interventions, use of drugs and identifying and treating reversible causes.
- CPR in pregnancy is almost similar to non-pregnant patients with some modifications as mentioned in the module (some of which notably are more team members, consideration for peri-mortem caesarean section, Hand positioning, IV access site)

## 2020 AHA GUIDELINES – KEY POINTS

The New 2020 AHA CPR guidelines came recently. Here are the highlights of the same.

### BLS

1. A sixth link, recovery added to all 4 chains of survival.
2. Emphasis on early epinephrine administration (within 5 minutes of cardiac arrest), repeat doses every 4 minutes to coincide with alternate pulse check.
3. Separate algorithm for pregnant women (for perimortem c/s if no ROSC in 4 minutes changed to 5 minutes) and Opioid related arrests (give rather than consider naloxone).
4. EEG, neurological imaging introduced as part of post resuscitation care.
5. Rate of breaths in paediatric age group increased to 1 breath every 2 to 3 seconds (20-30 bpm). 30 in children <1 year, 25 for > 1 years.
6. Advised to consider a cuffed ETT in paediatric age group.
7. New algorithm for paediatric tachycardia with pulse (QRS duration 0.09 sec).
8. Umbilical vein catheterization to be considered.
9. 2 thumb encircling compression in infants is better than 2 fingers compression.
10. FAS (facial drop, arm drift, speech difficulties) changed to FAST (time to call emergency number) for stroke.
11. Aspirin intake advised for all non-traumatic chest pain before arrival of EMS unless contraindicated.
12. Fetal monitoring not advised during maternal resuscitation. Post ROSC, yes. Rolling over on left post ROSC.
13. Ventilation rate in adults 1 breath every 6 seconds rather than 5-6 seconds.
14. Use of waveform capnography recommended during bag mask ventilation too.
15. Use of mobile technology reasonable.

### ACLS

1. Amiodarone and lidocaine are now considered equivalent as antiarrhythmic in cardiac arrest scenarios.
2. For adult symptomatic bradycardia, atropine dose changed to 1 mg from 0.5 mg. Dopamine dose for this changed from 2-20 mcg/kg/minute to 5-20 mcg/kg/minute.

3. Emphasis on prevention of hyperoxia, hypoxemia and hypotension.
4. Initial stabilisation split in to manage airway, manage respiratory parameters and manage hemodynamic parameters.
5. For adult tachycardia IV access and ECG moved earlier in the algorithm.
6. Updated ACS algorithm contact to balloon inflation goal less than or equal to 90 minutes.
7. Target SpO<sub>2</sub> >94% for stroke and general care; 92-98% for post cardiac arrest care.
8. During CPR, 15 seconds before pausing compressions, high performance team should check for pulse, precharge defibrillator, and prepare to deliver shock in 10 seconds or less to increase CCF>80% as 10% rise in CCF leads to 11% rise in survival.
9. Feedback devices or metronomes (can be downloaded on mobiles too).
10. IV preferred over IO.
11. New diagram to guide neuro prognostication.

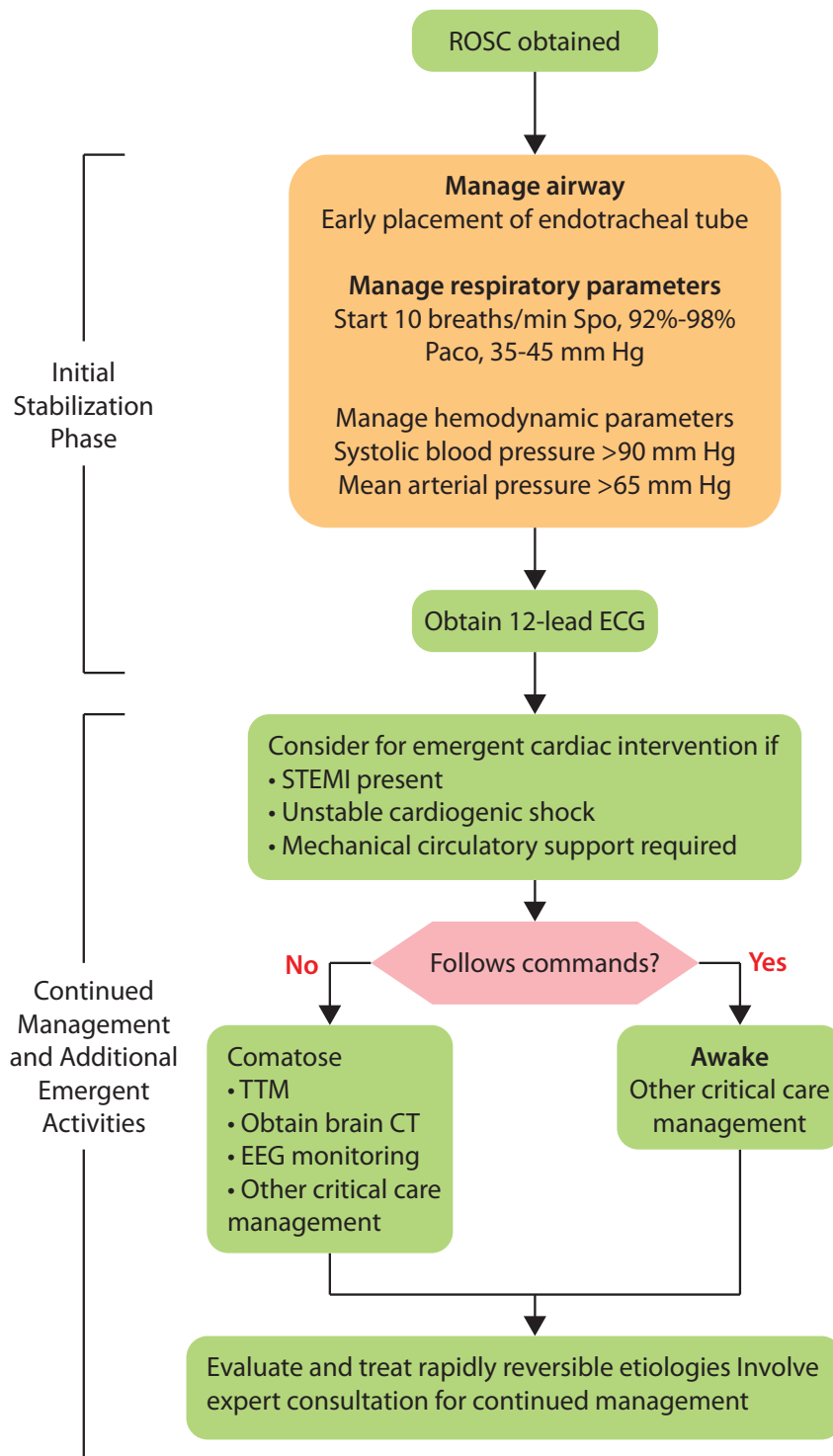
### Newly introduced concepts

1. CPR coach to help team leader. CPR coach ensures high quality BLS, while team leader focuses on other aspects like ACLS.
2. Double sequential defibrillation.
3. In Situ training.
4. Booster training.
5. Spaced learning approach.

### Chain of Survival 2020 guidelines



# Adult post cardiac arrest algorithm: AHA 2020



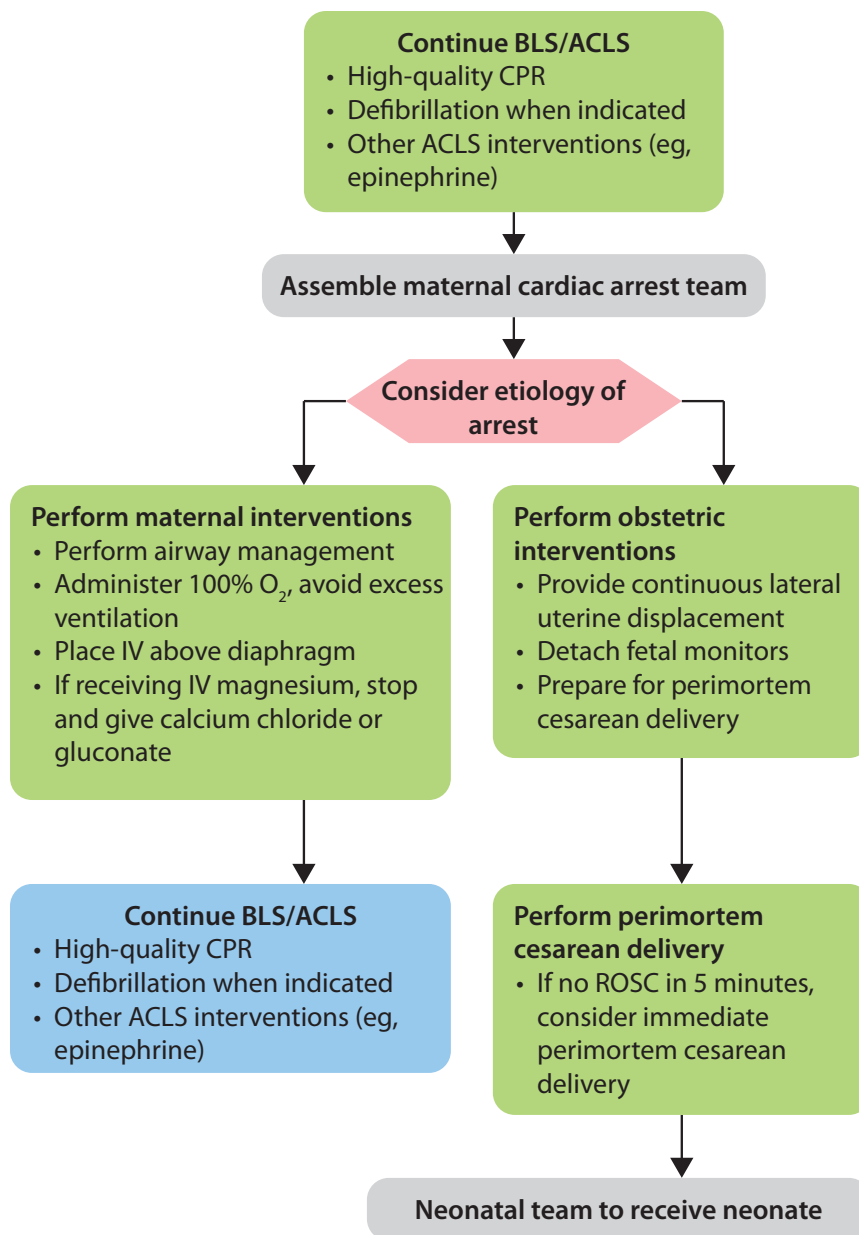
Initial Stabilization Phase
Resuscitation is ongoing during the post-ROSC phase, and many of these activities can occur concurrently. However, if prioritization is necessary, follow these steps: <ul style="list-style-type: none"> <li>• Airway management: Waveform capnography or capnometry to confirm and monitor endotracheal tube placement</li> <li>• Manage respiratory parameters: Titrate FIO<sub>2</sub> for SpO<sub>2</sub>, 92%-98%; start at 10 breaths/min; titrate to Paco<sub>2</sub> of 35-45 mm Hg</li> <li>• Manage hemodynamic parameters: Administer crystalloid and/or vasopressor or inotrope for goal systolic blood pressure &gt;90 mm Hg or mean arterial pressure &gt;65 mm Hg</li> </ul>
Continued Management and Additional Emergent Activities
These evaluations should be done concurrently so that decisions on targeted temperature management (TTM) receive high priority as cardiac interventions. <ul style="list-style-type: none"> <li>• Emergent cardiac intervention: Early evaluation of 12-lead electrocardiogram (ECG); consider hemodynamics for decision on cardiac intervention</li> <li>• TTM: If patient is not following commands, start TTM as soon as possible; begin at 32-36°C for 24 hours by using a cooling device with feedback loop</li> <li>• Other critical care management               <ul style="list-style-type: none"> <li>- Continuously monitor core temperature (esophageal, rectal, bladder)</li> <li>- Maintain normoxia, normocapnia, euglycemia</li> <li>- Provide continuous or intermittent electroencephalogram (EEG) monitoring</li> <li>- Provide lung-protective ventilation</li> </ul> </li> </ul>
H's and T's
<ul style="list-style-type: none"> <li>• Hypovolemia</li> <li>• Hypoxia</li> <li>• Hydrogen ion (acidosis)</li> <li>• Hypokalemia/hyperkalemia</li> <li>• Hypothermia</li> <li>• Tension pneumothorax</li> <li>• Tamponade, cardiac</li> <li>• Toxins</li> <li>• Thrombosis, pulmonary</li> <li>• Thrombosis, coronary</li> </ul>

© 2020 American Heart Association

Figure 7. Adult Post-Cardiac Arrest Care Algorithm.



## Cardiac Arrest in Pregnancy : In Hospital ACLS 2020 Algorithm



### Maternal Cardiac Arrest

- Team planning should be done in collaboration with the obstetric, neonatal, emergency, anesthesiology, intensive care, and cardiac arrest services.
- Priorities for pregnant women in cardiac arrest should include provision of high-quality CPR and relief of aortocaval compression with lateral uterine displacement.
- The goal of perimortem cesarean delivery is to improve maternal and fetal outcomes.
- Ideally, perform perimortem cesarean delivery in 5 minutes, depending on provider resources and skill sets.

### Advanced Airway

- In pregnancy, a difficult airway is common. Use the most experienced provider.
- Provide endotracheal intubation or supraglottic advanced airway.
- Perform waveform capnography or capnometry to confirm and monitor ET tube placement.
- Once advanced airway is in place, give 1 breath every 6 seconds. (10 breaths/min) with continuous chest compressions.

### Potential Etiology of Maternal Cardiac Arrest

- Anesthetic complications
- Bleeding
- Cardiovascular
- Drugs
- Embolic
- Fever
- General nonobstetric causes of cardiac arrest (H's and T's)
- Hypertension

© 2020 American Heart Association

Figure 9. Cardiac Arrest in Pregnancy In-Hospital ACLS Algorithm.

## CHECK YOUR PROGRESS

- The first step in approaching an emergency collapsed patient is
  - Scene safety
  - Identify consciousness
  - Check immediately carotid pulse and respiration to see signs of life
  - Call 108 for help
  - Legs to be elevated



- ii. The Correct ratio of chest compression in adult patients when there are two rescuers available for giving CPR is
  - a. 3:1
  - b. 15:2
  - c. 30:2
  - d. 5:1
  
- iii. The correct depth of chest compression in an adult patient is
  - a. Minimum 5 cm , maximum 6 cm
  - b. Minimum 6 cms
  - c. Maximum 5 cm
  - d. Varies as per the patient's body weight and physique
  
- iv. Defibrillation is part of Basic life support
  - a. True
  - b. False
  - c. Depends only on availability and training
  
- v. Full form of AED is
  - a. Automatic electrical defibrillator
  - b. Auxillary Electrical defibrillator
  - c. Automated external defibrillator
  - d. Automatic Early defibrillator
  
- vi. Ideally a ACLS team should have how many members, draw a diagram showing their positions and roles.
  
- vii. Adrenaline is used in ACLS at which if the following dose
  - a. 1 mg every cycle of CPR
  - b. 1 mg every 3 to 5 minutes
  - c. 1 to 2 mg every 5 minutes
  - d. Dose can be used as per clinical acumen
  
- viii. Write short note on Hands only CPR.
  
- ix. Draw a flowchart of basic life support for a cardiac arrest patient.
  
- x. Draw a flowchart for ACLS in non-pregnant patient.

xi. Highlight the differences in Pregnant Vs Non pregnant patient CPR.

## References

Garg R, Ahmed SM, Kapoor MC, Mishra BB, Rao SC, Kalandoor MV, et al. Basic cardiopulmonary life support (BCLS) for cardiopulmonary resuscitation by trained paramedics and medics outside the hospital. *Indian J Anaesth* 2017;61:874-82.

Garg R, Ahmed SM, Kapoor MC, Rao SC, Mishra BB, Kalandoor MV, et al. Comprehensive cardiopulmonary life support (CCLS) for cardiopulmonary resuscitation by trained paramedics and medics inside the hospital. *Indian J Anaesth* 2017;61:883-94.

## Cardiac Arrest in Pregnancy

Farida M. Jeejeebhoy, MD, et al on behalf of the American Heart Association Emergency Cardiovascular Care Committee, Council on Cardiopulmonary, Critical Care, Perioperative and Resuscitation, Council on Cardiovascular Diseases in the Young, and Council on Clinical Cardiology. *Circulation*. Volume 132, Issue 18, 3 November 2015, Pages 1747-1773

Ashish R. Panchal et al. 2018 American Heart Association Focused Update on Advanced Cardiovascular Life Support Use of Antiarrhythmic Drugs During and Immediately After Cardiac Arrest: An Update to the American Heart Association Guidelines for Cardiopulmonary Resuscitation and Emergency Cardiovascular Care. *Circulation*. 2018;138:e740–e749

Kleinman ME, Brennan EE, Goldberger ZD, Swor RA, Terry M, Bobrow BJ, Gazmuri RJ, Travers AH, Rea T. Part 5: Adult Basic Life Support and Cardiopulmonary Resuscitation Quality: 2015 American Heart Association Guidelines Update for Cardiopulmonary Resuscitation and Emergency Cardiovascular Care. *Circulation*. 2015 Nov 3;132(18 Suppl 2):S414-35.

Merchant RM, Topjian AA, Panchal AR, et al. Part 1: executive summary: 2020 American Heart Association Guidelines for Cardiopulmonary Resuscitation and Emergency Cardiovascular Care. *Circulation*. 2020;142(suppl 2):In press.

# 21

## Neonatal CPR

---

### THE PRINCIPLES OF RESUSCITATION

The cardinal principles of resuscitation are T, A, B, C:

- T. Prevent Hypothermia (Temperature < 36.5 degree centigrade)-provide warmth, dry the baby and remove the wet linen.**
- A. Ensure an open AIRWAY through proper position and clearing the passage of any secretions.**
- B. To initiate BREATHING by tactile stimulation and PPV when necessary.**
- C. To maintain CIRCULATION with chest compressions and medication.**

### Preparation for delivery:

At every birth, adequate preparations are to be made to resuscitate a newborn because the need for resuscitation cannot always be predicted.

- Before every delivery ensure that all essential equipment is in place and in working condition.
- Replace the broken equipment
- Equipment of the appropriate size should be always available.
- The volume of the bag should not be more than 500 ml and the pressure of an electrical suction machine should not exceed a negative pressure of 100 mmHg.
- Mucus extractor and suction catheter are disposable and should be discarded after single use.
- Bag and mask, stethoscope, radiant warmer and suction machine should be disinfected

Once you have assessed that the newborn requires resuscitation, the steps should be initiated as per the algorithm

**Initial Steps of Resuscitation** (steps for resuscitation are mentioned at the end of the chapter as Annexure 1)

If the baby does not initiate breathing or crying at birth, cut the cord immediately and place the baby under radiant warmer to proceed with resuscitation as per protocol.

### Provide initial steps under radiant warmer

The warmer should be pre warmed prior to the delivery for at least 20 minutes in the manual mode. Place the baby supine under pre radiant warmer, with the head positioned towards the side opposite to the display panel. This shift under the warmer helps in full visualization of the baby, prevents the baby from getting hypothermic and gives enough space to work and move around the baby.

### i. Position by slightly extending the neck

The baby should be positioned on the back, with the neck slightly extended in the “sniffing” position (to open the airway). To help maintain the correct position, you may place a rolled blanket or towel under the shoulders 1/2 to 3/4th inch). This will bring the posterior pharynx, larynx, and trachea in line, which will facilitate unrestricted air entry. Care should be taken to prevent hyperextension or flexion of the neck, since either may restrict air entry.

### ii. Clearing of the airway

Procedure of Oro-pharyngeal suction

Secretions may be removed from the airway by wiping the nose and clearing the oropharynx by applying suction through a suction catheter of 10-12F size (12-14 F in case of meconium).

The negative pressure for suction should be between 80-100 mm Hg, not exceeding 100 mm Hg.

The mouth is suctioned before the nose to ensure that there is nothing to aspirate if the baby takes gasp while the nose is being suctioned. You can remember mouth before nose because “M” comes before “N” in alphabets. Do not do deep or prolonged suction (no more than 5 cm in mouth and 2 cm in nose and for not more than 3-5 seconds) Suction should be gentle and avoid stimulating posterior pharyngeal wall.

Caution: Vigorous suctioning may cause bradycardia and apnea due to vagal nerve stimulation. If bradycardia occurs, stop suctioning and re-evaluate the heart rate.

### iii. Dry the baby using warm towels. Discard wet towels.

### iv. Stimulate the baby

Both drying and suctioning stimulate the newborn. For many newborns, these steps are enough to induce respiration. If the newborn does not have adequate respiration, additional tactile stimulation may be provided briefly to stimulate breathing.

Safe and appropriate method of providing additional tactile stimulation is only by gently rubbing the newborn’s back (twice). Inappropriate and vigorous stimulation is not helpful and can cause serious injury.

### v. Reposition the baby

Bag and Mask ventilation also known as Positive Pressure Ventilation (BMV/ PPV)

If a baby is still not breathing well/ gasping /apneic after initial steps, positive pressure ventilation should be immediately initiated

Continuing to provide tactile stimulation or administering free –flow oxygen to a non-breathing baby is deleterious and delays appropriate management

Equipments needed for PPV

1. Self-inflating bag: Appropriate size of bag should have a volume of 250-500 ml.

Appropriate sized masks- Too big masks cover eyes & extends beyond the lower border of chin and too small masks don’t cover the nose & the mouth effectively. Recommended sizes of masks are 0 and 1.

#### vi. Position yourself at the bedside

You should position yourself at the side or head of the baby to use the resuscitation bag effectively. Either position will allow you to hold the mask on the baby's face comfortably and allow you to have an unobstructed view of the abdomen and chest. If you are right-handed, you probably will feel most comfortable controlling the bag with your right hand and the mask with your left hand. If you are left-handed, you will probably want to control the bag with your left hand and hold the mask with your right hand.

It is important that the bag is positioned so that it does not block your view of the baby's chest, since you need to be able to observe chest movement during ventilation. It is reiterated again that the functionality of the bag and mask should be checked always before any delivery so that one is well prepared if need be.

#### vii. Positioning the baby and mask on the face

The mask should be placed on the face so that it covers the nose and mouth, and the tip of the chin rests within the rim of the mask. You should begin by cupping the chin in the mask and then covering the nose.

The mask usually is held on the face with the thumb, index, and/or middle finger encircling the rim of the mask in shape of letter "C" while the ring and fifth fingers bring the chin forward to maintain a patent airway. Once the mask is positioned, using light downward pressure on the rim of the mask can form an airtight seal. Care should be taken in holding the mask.

#### viii. Observe the following precautions:

- Do not "jam" the mask down on the face. Too much pressure can mould (flatten) the back of the head and bruise the face.
- Be careful not to rest your fingers or hand on the baby's eyes.
- Make sure that adequate seal has been made between mask and face otherwise air would leak from the mask leading to ineffective ventilation.

#### ix. Initiation of ventilation

Start ventilation by squeezing the bag to deliver breath. Remember, the lungs of a fetus are filled with fluid, so the first few breaths will often require higher pressures and longer inflation times than will subsequent breaths. Adequate pressure required to squeeze the bag should be just enough to produce gentle chest rise as it happens in normal breathing.

Remember if the baby appears to be taking a very deep breath, the lungs are being over inflated. You are using too much pressure and there is danger of producing an air leak in the lungs.

Initiate ventilation at room air (21% FiO<sub>2</sub>) in babies ≥ 35 weeks gestation and at 21-30% FiO<sub>2</sub> in babies < 35 weeks gestation.

#### How often should you squeeze the bag?

During the initial stages of neonatal resuscitation, breaths should be delivered at a rate of **40 to 60 breaths per minute** (Fig 1.11). To help maintain a rate of 40 to 60 breaths per minute, try saying to yourself as you ventilate the newborn: "**Breathe – Two – Three, Breathe – Two – Three**". If you squeeze the bag on "Breathe" and release while you say "Two, Three", you will probably find you are ventilating at a proper rate.

After 5 breaths check chest rise.

### **Ensure chest rise**

Start ventilation with bag and mask, look for chest movement with each breath to ensure adequacy of ventilation. If the chest movement is absent or inadequate during the initial 5 breaths then you should immediately take “steps to improve ventilation”.

If there is no chest rise or there is no rise in HR-**Take ventilation corrective measures.**

### **Techniques to improve PPV using bag and mask.**

	<b>Problem</b>	<b>Remedial step</b>
M	Inadequate seal	Mask adjusted to ensure airtight seal
R	Inappropriate position	Reposition the head in sniffing position
<b>Try PPV and Reassess Chest Movement</b>		
S	Blocked	Suction the airway
O	Airway	Open baby’s mouth and ventilate
<b>Try PPV and Reassess Chest Movement</b>		
P	Inadequate pressure	Increase Pressure by squeezing the bag with more pressure till a chest rise is visible
<b>Try PPV and Reassess Chest Movement</b>		
A	No improvement with above steps	Consider Alternative airway like endotracheal intubation (or laryngeal mask airway if expertise present)
<b>Try PPV and Reassess Chest Movement</b>		

Adequate passive ventilation is usually indicated by either a rapidly increasing heart rate or a heart rate that is maintained faster than 100 beats per min. Continue ventilatory support until the baby has established normal regular breathing.

If the baby is breathing adequately then gradually reduce the rate and volume of breaths and watch for the baby’s breathing. If the baby is breathing well then stop positive pressure ventilation while continuing to gently stimulate the baby to take deeper breaths. Provide observational care.

An oxygen reservoir is an appliance that can be placed over the bag's air inlet. The advantage of reservoir is to get 90-100% oxygen at the patient outlet as compared to only 40 % without reservoir, with oxygen connected to oxygen inlet. If no oxygen is attached to the bag, it provides only 21% i.e. room air.

After providing 'Effective PPV' (that inflates lung) for 30 seconds assess Respiration and HR, following situations are possible

**A.**

If heart rate is above 100/min with Sustained spontaneous breathing.

1. Stop PPV

**B.**

If the heart rate is 60-100bpm

1. Continue PPV
2. Reassess respiratory effort, heart rate every 30 seconds

**C.**

If heart rate is < 60 /min

1. Start chest compressions with PPV

## Chest compressions

- **When to initiate**

1. If after 30 seconds of effective PPV, the heart rate remains below 60 bpm.

- **Technique of chest compression**

1. Thumb technique
2. Two finger technique is not recommended

- **Site of compression**

It is done in lower third sternum in midline. The area lies between nipples. This can be located by running fingers along costal margin and localizing the xiphoid and placing the fingers above the xiphoid.

- **Pressure for compression**

Sternum should be depressed to a depth of approximately one-third of the anterior-posterior diameter of the chest.

- **Rate of compression**

Chest compressions should be accompanied by PPV with 100% O<sub>2</sub>. For every 3 compressions, 1 breath is delivered (hence in a minute, 90 compressions and 30 breaths are given). The adequate chest compression rate is 90 compressions per minute synchronized with 30 bpm and given with a cadence of "one-and-two-and-three-and-breath".



- **When to stop chest compressions**

After 60 seconds of coordinated Chest compressions with PPV, assess the baby.

- 1. If the heart rate is above 60bpm**

Stop chest compressions but continue PPV effectively @ 40-60 breaths per minute. Then withdraw PPV gradually later when heart rate is more than 100bpm and the baby is breathing spontaneously. This baby will need post observational care in SNCU.

- 2. If the baby is not improving**

Look for effective PPV; intubate if you have not and provide 100% supplemental oxygen. Check the depth of chest compressions & coordinate it well with PPV.

If the baby's heart rate is still < 60/min despite total 60 seconds of coordinated chest compression and PPV, insert an umbilical catheter and give IV adrenaline and continue chest compressions and PPV using 100% O<sub>2</sub>.

## Drugs

The role of drugs is very limited. In few infants who fail to improve with ventilation and chest compression, medication becomes necessary. Only the following drugs are required for neonatal resuscitation: -

1. Adrenaline
2. Volume expanders (Normal Saline)

**Remember atropine, dexamethasone, calcium, dextrose etc. are not indicated for resuscitation in the delivery room.**

- **Adrenaline**

**Indication:** Heart rate is below 60 beats per min despite continuing both chest compression and PPV for 60 sec.

**Dose and route:**

- In order to prepare Injection adrenaline @ 1:10,000 dilution, mix 1ml of injection adrenaline (1:1000) with 9 ml of normal saline.
- Through intravenous route in a dose of 0.1 to 0.3 ml per kg of 1:10,000 dilutions. Awaiting IV access, it may be given through endotracheal route in a dose which is 10 times the intravenous dose (0.5-1 ml/kg of 1: 10,000 dilution). Absorption through intratracheal route is unpredictable.

Check the baby's HR 60 seconds after administering Adrenaline. Dose can be repeated after 3-5 minutes if no response.

- **Volume Expanders** are indicated if the baby is in shock, there is evidence of blood loss and baby is responding poorly to resuscitation

1. Give 10 ml/kg of Normal Saline over 5- 10 minutes intravenously or
2. Ringer's Lactate.
3. O Rh negative packed red blood cells should be considered as a part of the volume replacement when severe fetal anemia is documented and expected.

## Management of Meconium stained Amniotic Fluid (MSAF)

The procedures like routine intrapartum suctioning of mouth and nose before delivery of shoulder and post natal tracheal suctioning of non-vigorous babies are no more recommended.

### Skill

#### How to provide ventilation using a self-inflating bag

1. Ensure the device is assembled correctly.
2. Call for help.
3. Place the baby on a firm, flat and clean surface.
4. Position the head of baby in a sniffing position.
5. The rescuer should stand at the head end of the baby.
6. Apply the face mask firmly and gently to fit snugly covering the chin, mouth and nose to achieve an airtight seal.
7. Squeeze the bag between thumb and two fingers using the dominant hand in **room air**.

Deliver a rate of 40-60 breaths per minute. Call loudly 'squeeze, two-three'. Deliver a breath when you call squeeze and allow the bag to recoil during calling 'two-three'.

### Skill

**Giving free flow oxygen** - Central cyanosis requires supplemental oxygen, which can be provided by an oxygen mask or oxygen tube held in cupped hand over baby's face or by flow inflating bag and mask. The flow of oxygen should be at least 10L/minute.

#### Cleaning and disinfection of Bag & mask :

Disassemble all parts, wash thoroughly with warm water and soap. Soak in glutaraldehyde 2% for 30 minutes for disinfection and for 6 hours for sterilization. After removing from glutaraldehyde rinse with clean water, dry with sterile cloth and then reassemble. Disinfect daily and sterilize weekly. Clean mask with spirit between patient use.

### Skill

#### Disinfection of Bag and mask

<b>Face Mask</b>
<ul style="list-style-type: none"><li>• Disinfect daily and sterilize weekly</li><li>• Clean with detergent daily and after each use</li><li>• Immerse in 2% glutaraldehyde for 30 minutes</li><li>• <u>Rinse with clean water and dry with sterile linen (washed and sun dried).</u></li></ul>
<b>Resuscitation bag</b>
<ul style="list-style-type: none"><li>• Disinfect daily and sterilize weekly.</li><li>• Clean with detergent.</li><li>• Immerse in 2% glutaraldehyde for 30 minutes.</li><li>• <u>Rinse with clean water and dry with sterile linen.</u></li></ul>

## ANNEXURE-1

### Steps for Newborn Resuscitation

	SI NO.	Steps	
<b>0-30 Seconds</b>	1.	Ensures all the equipments/ material are kept in readiness prior to delivery.	
	2.	Receives the baby in pre warmed, dry, sterile linen. Dries the baby.	
	3.	Discards wet towel and wraps the baby in another towel.	
	4.	Assesses breathing.	
	5.	If breathing, place on mothers abdomen to provide Routine care: <ul style="list-style-type: none"> <li>• warmth (skin to skin care).</li> <li>• Assure open airway if needed,</li> <li>• Cut cord in 1-3 min.</li> </ul> Ongoing evaluation of neonate.	
	6.	If not breathing: <ul style="list-style-type: none"> <li>• Clamps and cuts the cord immediately.</li> </ul>	
	7.	Shifts the baby under Radiant Warmer (which is switched on at least 20mins before the delivery).	
	8.	Positions the baby's head in sniffing position with a shoulder roll (rolled towel/sheet).	
	9.	Performs gentle suction of the airway if visible secretions are present: <ul style="list-style-type: none"> <li>• Gently suctions the mouth by using Dee lee's mucus trap.</li> </ul>	
	10.	Dry the baby and remove wet linen.	
	11.	Evaluates if baby is breathing well. If not, provides tactile stimulation (Gently rubs the back of the baby).	
	12.	If baby is still not breathing, Starts bag and mask ventilation.	
<b>Use of bag and mask</b>			
<b>31- 60 seconds</b>	1.	Repositions the baby using the shoulder roll to keep the neck slightly extended.	
	2.	Identifies the correct size of the mask.	
	3.	Places the mask over newborn's mouth and nose correctly covering the tip of the chin, mouth and bridge of the nose to make an airtight seal	

31- 60 seconds	4.	<p>Squeezes the resuscitation bag at the rate of 40-60 breaths per minute.</p> <p>Squeeze.....Two.....Three.....Squeeze</p> <p>Looks for chest rise with each ventilation.</p> <p>Start resuscitation at room air in babies <math>\geq</math> 35 weeks gestation and at 21-30% FiO<sub>2</sub> in babies below 35 weeks gestation.</p>	
	5.	<p>If the chest is not rising</p> <ul style="list-style-type: none"> <li>• Repositions the baby's head and try again</li> <li>• Repositions the mask and checks that the seal is airtight</li> <li>• If there are a lot of secretions, sucks the airway again.</li> <li>• Squeezes the bag little harder</li> </ul>	
	6.	<p>After 30 seconds of bag and mask ventilation, assess the baby's breathing.</p>	
	7.	<p>If not breathing well, count heart rate /cord pulsation for 6 seconds.</p> <ul style="list-style-type: none"> <li>• If heart rate <math>&gt;</math> 100/minute, continues bag and mask ventilation and reassess every 30 seconds. If baby is breathing well, stops ventilation.</li> <li>• If heart rate <math>&lt;</math> 100/minute, continues bag and mask ventilation and refer to higher center</li> <li>• Starts Oxygen if required.</li> </ul>	

### C) Chest Compression and Medication

SI No.	Steps	
1.	Evaluate if baby is breathing well after 30 seconds of effective bag and mask ventilation.	
2.	<p>If baby is not breathing well, checks heart rate, calls for help</p> <ul style="list-style-type: none"> <li>• If HR <math>&gt;</math>60 continues bag and mask ventilation.</li> <li>• If HR <math>&lt;</math>60 continues bag and mask ventilation and calls the other partner to administer chest compression for 60 seconds.</li> </ul> <p>One – and –two-and –three-and-breathe - and</p>	
3.	<p>Evaluates breathing and heart rate after 60 seconds</p> <ul style="list-style-type: none"> <li>• If heart rate <math>&gt;</math> 60 and not breathing- continues bag and mask ventilation and stop chest compressions. Once the baby is breathing well and HR <math>&gt;</math> 100 slowly withdraws bag and mask ventilation and provides post-resuscitation care.</li> <li>• If heart rate <math>&lt;</math> 60 and not breathing- continues bag and mask ventilation with chest compression and administers medication (Epinephrine 0.1 – 0.3 ml/kg of 1:10,000 solution IV).</li> </ul>	

# 22

## Fluid Therapy & Electrolytes

### INTRODUCTION:

- Intravenous (IV) fluids are chemically prepared solutions which are administered to the patients directly through a vein. It can be intermittent or continuous.
- Compare with other routes of administration, the intravenous route is the fastest way to deliver fluids and medication throughout the body.
- Taking a adequate venous access, having a essential knowledge about different types of intravenous fluids, common electrolyte disturbances and their management is essential for practicing obstetric anaesthesiologist

### LEARNING OBJECTIVES:

After going through this module, you should be able to describe the:

Learning Objective	Knowledge	Skills
To understand various types of intravenous fluids, their composition, uses, and side effects.	✓	
Comparison of crystalloids and colloids	✓	
How to do an appropriate venesection?	✓	✓

### TYPES:

IV fluids come in different forms and have different impact on the body. It is therefore important to understand different type of IV fluids along with their indications:

**IV fluids come in four different forms:**

- A. Colloids.
- B. Crystalloids.
- C. Blood and Blood Products.
- D. Oxygen-carrying Solution.

Understanding of these IV fluids is important because each has a different impact on the body and particular indication for use.

### Colloid Solutions:

- Colloid solutions are IV fluids that contain solutes in the form of large protein or other similar sized molecules.
- These proteins and molecules are so large that they cannot pass through the walls of the capillaries and into the cells.
- Colloids remain in the blood vessels for long periods of time and can significantly increase the intravascular volume. The protein in the solution withdraws water from the cells into the blood vessels. It is beneficial in short term to maintain blood volume.
- Colloid is helpful in reducing oedema because they draw fluid from interstitial and intracellular compartment into the vascular compartments.
- Initially these fluids stay almost entirely in the intravascular space for a prolonged period as compared to crystalloids.

### Types:

- **Synthetic:** e.g. Dextran, Hetastarch.
  - **Dextran:** Polysaccharide used for volume expansion associated with anticoagulation. These are used for vascular surgery - prevent thrombosis.
  - Infusion exceeding 20 ml/Kg/day can interfere with blood typing, renal failure and prolong Bleeding Time.
- **Non-synthetic:** e.g. Human serum albumin (5%, 25%).
  - **5% Albumin:** will remain in the intravascular space. It is the most efficient way to treat shock. This effect is not permanent in patients who are hypo-albuminemic. Colloids are large molecular weight solutions (normally molecular weight > 30,000 Daltons).

### Advantages of Colloids:

- Increase plasma volume.
- Less peripheral oedema.
- Requires smaller volumes for resuscitation.
- Intravascular half-life 3-6 hours.

### Disadvantages of Colloids:

- Much higher cost than crystalloid solutions.
- Small but significant incidence of adverse reactions.
- Because of gelatinous properties, these can cause platelet dysfunction and interfere with

fibrinolysis and coagulation factors thus possibly causing coagulopathy in large volumes.

- These fluids can cause dramatic fluid shifts which can be dangerous if they are not administered in a controlled setting.
- Increase incidence of acute kidney injury and more need for renal replacement therapies in ICU patients.
  - With growing evidence and lot of recent scientific studies pointing more harm in using colloids (Synthetic colloids), Colloids are being used less and less in critically ill patients and in ICU and even in perioperative setup.

## Crystalloid Solutions:

- Crystalloid solutions are the primary fluid used for IV therapy made up of water and electrolytes.
- These crystalloids contain electrolytes (e.g., sodium, potassium, calcium, chloride) but lack the large proteins and molecules found in colloids.
- Crystalloids come in many preparations and are classified according to their “tonicity”. A crystalloid’s tonicity describes the concentration of electrolytes solutes dissolved in the water, as compared with that of body plasma (fluid surrounding the cells).

### Types:

- Isotonic Fluids.
- Hypotonic Fluids.
- Hypertonic Fluids.

### Isotonic Fluids:

- Have a total osmolality close to that of extra cellular fluids (ECF) and do not cause RBCs to shrink or swell.
- Isotonic have a tonicity equal to the body plasma. When administered to a normally hydrated patient, isotonic crystalloids do not cause a significant shift of water between the blood vessels and the cells. Thus, there is no (or minimal) osmosis occurring.
- Helpful with patients who are hypotensive or hypovolemic.

### Hypotonic Fluids:

- Less osmolarity than serum. (meaning in general, less sodium ion concentration than serum).
- These fluids DILUTE serum thus decreasing osmolarity. Water moves from the vascular compartment into the interstitial fluid compartment → interstitial fluid becomes diluted → osmolarity decreases → water is drawn into adjacent cells.
- **Caution** with use because sudden fluid shifts from the intravascular space to cells can cause cardiovascular collapse and increased ICP in certain patients.

**Examples:** half normal saline, dextrose 2.5% (D2.5W).

**Complications of excessive use of hypotonic solutions include:** Intravascular fluid depletion, Decreased blood pressure and cellular oedema.



### Hypertonic Fluids:

- These have a higher osmolarity than serum.
- These fluids pull fluid and sometimes electrolytes from the intracellular/interstitial compartments into the intravascular compartments. Useful for stabilizing blood pressure, increasing urine output, correcting hypotonic hyponatremia and decreasing oedema.
- These can be dangerous in the setting of cell dehydration.
- Examples: 5% dextrose in 0.9% NaCl (D5NS), 3% NaCl, 10% dextrose in water (D10W).

### Advantages of Crystalloids:

- They are inexpensive.
- Easy to store with long shelf life.
- Readily available with a very low incidence of adverse reactions.
- There are a variety of available formulations that are effective for use as replacement fluids or maintenance fluids.

### Disadvantages of Crystalloids:

It takes approximately 2-3 x volume of a crystalloid to cause the same intravascular expansion as a single volume of colloid.

- Causes peripheral oedema.
- Dilute plasma proteins.

### Overview:

- Despite the limitations of most of the types of above-mentioned fluids, it is to be noted that the isotonic classified fluids are the most commonly used fluids in resuscitation, maintenance phase of a perioperative or critically ill patient in ICU.
- Blood and blood products have specific indications and have more restrictive indications for transfusion compared to older liberal transfusion guidelines as per the emerging evidence in medical literature.

**Let's have a brief outlook at commonly used fluid types:**

### 0.9% Normal Saline:

- Basically 'Salt and Water'
- Principal fluid used for IV resuscitation and replacement of fluid & salt loss.
- Contains: Na<sup>+</sup> 154 mmol/l, K<sup>+</sup> - Nil, Cl<sup>-</sup> 154 mmol/l.
- Distribution:
  - Stays almost entirely in the Extracellular space.
  - Of 1 litre, approx. 700 ml stays Extracellular fluid; 300 ml moves Intravascular fluid. (Though this is oversimplification and depends upon lots of factors)
- Uses:
  - Shock & Resuscitation

- Hyponatremia (depends on the sodium level and type of hyponatremia)
- Resuscitation, maintenance IV fluid in a patient who needs fluid for daily intake matching especially when enteral intake is restricted / not feasible.
- Side effects:
  - Can lead to overload if administered excessively
  - Use with caution in patients with heart failure or oedema.
  - Excessive use may lead to hyperchloremic metabolic acidosis.

#### 0.45% Normal saline: ('Half' Normal Saline = Hypotonic saline):

##### **Use with caution!**

- Can be used in severe hyperosmolar states, e.g. severe dehydration.
- Leads to Hyponatraemia if plasma sodium is normal.
- Uses: Water replacement or Gastric fluid loss from NG or vomiting.
- May cause cardiovascular collapse or increased intracranial pressure.

#### 1.8, 3.0, 7.0, 7.5 and 10% Saline: (Hypertonic saline):

- Reserved for plasma expansion with colloids or acute hyponatremia.
- In practice it is rarely used in routine circumstances.
- Large volumes will cause Hypernatremia and IC dehydration.
- Acute excess correction of acute hyponatremia may be dangerous

#### Lactated Ringers:

- Isotonic (osmolality = 304).
- Lower Na<sup>+</sup> than plasma: 130 mEq.
- Uses: Dehydration, Burns, Lower GI fluid loss, Acute blood loss, Hypovolemia.
- Contains potassium, use in caution with renal failure patients.
- To be used in caution in patients with liver disease (especially extensive disease), because of presence of lactate.
- One of the most common IV fluids used for resuscitation and maintenance.

#### 5% Dextrose: (D5W) "Sugar and Water":

- Primarily used to maintain water balance in patients who are not able to take anything by mouth; Commonly used post-operatively in conjunction with other electrolyte containing fluids such as Ringer lactate and normal saline.
- Provides some calories [ approximately 10% of daily requirements].
- Regarded as 'electrolyte free' – contains No Sodium, Potassium, Chloride or Calcium.
- Distribution: <10% Intravascular; > 66% intracellular.
- When infused, is rapidly redistributed into the intracellular space; Less than 10% stays in the intravascular space therefore it is of limited use in fluid resuscitation.

- Although oversimplification, a rough approximation can be guessed from the notion that for every 100ml blood loss – needs 1000ml dextrose replacement [10% retained in intravascular space].
- Common cause of iatrogenic hyponatraemia in surgical patient.
- Uses: Fluid loss Dehydration Hyponatremia.
- Use cautiously in renal and cardiac patients.
- Can cause fluid overload.
- Dilution Hyponatremia can lead to cerebral oedema in patients with central nervous system disorder
- Should be avoided to be co-loaded with blood since a risk of haemolysis is present.

#### Dextrose Saline: 'Salt and Sugar':

- Similar indications to 5% dextrose; Provides Na<sup>+</sup> 30mmol/l and Cl<sup>-</sup> 30mmol/l.
- Primarily used to replace water losses post-operatively.
- Limited indications outside of post-operative replacement.
- Advantage: Does not commonly cause water or salt overload.
- Disadvantages: Combined for dextrose - hyperglycaemia / normal saline – hyperchloremic metabolic acidosis

#### Blood and Blood Products:

- Blood and blood products (e.g., platelets, packed red blood cells, plasma) are the most desirable fluids for replacement.
- Unlike colloids and crystalloids, the haemoglobin carries oxygen to the cells. Not only is the intravascular volume increased, but the fluid administered can also transport oxygen to the cells.
- The universal compatibility of O-negative blood makes it the ideal choice for administration in emergent situations.
- We will see details about blood and blood products in upcoming chapter.

#### Oxygen-Carrying Solutions:

- These are synthetic fluids that carry and deliver oxygen to the cells. These fluids, which remain experimental, show promise for the prehospital care of patients who have experienced severe blood loss or are otherwise suffering from hypovolemia. It is hoped that oxygen-carrying solutions will be similar to crystalloid solutions in cost, storage capability, and ease of administration, and be capable of carrying oxygen, which presently can only be accomplished by blood or blood products.

#### Indications of IV Fluids:

- Establish or maintain a fluid & electrolyte balance.
- Administer continuous or intermittent medication.
- Administer bolus medication.

- Administer fluid to keep vein open.
- Administer blood or blood components.
- Administer intravenous anaesthetics.
- Maintain or correct a patient's nutritional state.
- Administer diagnostic reagents.
- Monitor hemodynamic functions.

### How to use it?

- H<sub>2</sub>O is the most abundant constituent in the body, approx. 50% of body weight in women and 60% in men.
- Total body water is distributed into two major compartments: 55-75% ICF and 25-45% ECF (which is intravascular and extravascular in a ratio of 1:3)
- Water balance is maintained by plasma osmolality (solute or particle concentration of a fluid) and the normal range is 275 to 290 mOsm/kg and is VERY sensitive.
- To maintain a steady state, water intake must equal water excretion.
- Obligate water losses: urine, stool (minor component), & evaporation of from skin & respiratory tract.

### Fluid Requirements:

- Normal adult requires approximately 35ml/kg/day.
  - Ideal Body Weight (IBW) = 50 (m) 45.5 (f) + (2.3 per in. > 5 ft.).
  - This assumes normal fluid loss.
  - Urine.
  - Stool.
  - Insensible.
- Watch Intake Output carefully and be aware of other losses.
- Fever increases insensible loss by 200ml/day for each degree (C).
- Monitor abnormal GI loss e.g. NGT suctioning.
- "4, 2, 1" Rule: (A rough approximation and probably an oversimplification)
  - First 10 kg= 4ml/kg/hr.
  - Second 10 kg= 2ml/kg/hr.
  - 1ml/kg/hr thereafter.
- In adults remember IV Fluid rate = weight (kg) + 40.
  - 70 + 40 = 110ml/hr.
  - Assumes no significant renal or cardiac disease and Nil Per Oral.
  - This is the maintenance IVF rate; it must be adjusted for any dehydration or ongoing fluid loss.
  - Conversely, if the patient is taking some orally, the IVF rate must be decreased accordingly.
- Daily lytes, BUN, Cr, I/O, and if possible, weight should be monitored in patients receiving

significant IVF.

## Daily Electrolyte Requirements:

### Sodium:

- 1-3 mEq/kg/day, normal levels in blood around 135 to 145mEq / litre
- 70 kg male requires 70-210 mEq NaCl, 2600 ml fluid per day.
- 0.45% saline contains 77 mEq NaCl per liter.
- $2.6 \times 77 = 200$  mEq, thus, if 0.45% saline is used as MIVF assuming no other volume or electrolyte issues, around 2500 ml can be used.
- Hypo or Hyper natremia management depends upon the absolute sodium levels along with clinical features, mainly the neurological symptoms. If found to be symptomatic, ideally if the time permits the patient should be referred to a higher centre where more frequent monitoring, ICU monitoring and expertise helps is available. Rapid correction of hypernatremia leads to serious CNS problems.

### Potassium:

- 1 mEq/kg/day
- Potassium is a major intracellular ion and is maintained in a very fine balance in body and in the plasma (intravascular compartment) through delicate homeostasis measures.
- Potassium increase or decreases i.e. Hyper or hypo kalemia can be both dangerous. The normal potassium levels are 3.5 to 5.5mEq/litre.
- Hypo or hyperkalaemia can affect body organ system, most commonly being the cardiovascular system, the muscular systems and the other. Thus, a decision to treat hypo or hyperkalaemia is based on the absolute values as well as the clinical picture along with ECG changes associated with it.
- Whenever feasible, after initial treatment is started for the above condition, the patient should be ideally referred to the higher tertiary care centre for expertise management or at least a teleconsultation should be sought before shifting the patient as to ensure what treatment has to be started.
- The main causes of significant morbidity or mortality in hyperkalaemia/hypokalaemia is through cardiac rhythm disturbances and ECG monitoring is important.
- **Hyperkalaemia**
  - is defined as levels more than 5.5mEq/litres.
  - There are many causes for hyperkalaemia – divided mainly into increased production or intake and/or decreased excretion from the body. The common conditions where this can be seen are after
    - Acute severe kidney injury
    - Metabolic acidosis
    - Hypermetabolic states like malignant hyperthermia, thyroid storm, neuroleptic malignant syndrome, or rhabdomyolysis
  - Can be treated with Glucose – insulin drip, beta adrenergic agonist nebulisation, calcium gluconate, sodium bicarbonate as well as potassium exchange resins and in refractory and severe cases with haemodialysis.

- Whereas the resins, dialysis, insulin and the beta agonist nebulisation actually help decrease the potassium levels either by excreting or pushing the potassium intracellularly, calcium and soda-bicarbonate helps decrease its adverse effects on the heart.
- **Hypokalaemia**
  - Defined as potassium levels less than 3.5mEq/l however symptoms are generally seen when the potassium levels are less than 3.0 mEq/l
  - Causes can be because of
    - Inadequate supplementation in critically ill patients
    - Excess gastrointestinal (upper especially) losses
    - Metabolic alkalosis
    - Renal losses
  - Potassium can be replaced either enterally or parenterally. Whenever not associated with significant severe symptoms, it should be replaced enterally. It mostly comes in the form of syrup.
  - If severe can be supplemented parenterally. Potassium is irritant to the veins as well as tissues, extravasation being associated with severe pain and at times with severe reaction.
  - It is ideally given through central line with 10 to 20 meq diluted to at least 50 ml, if central vein is not available, it should be further diluted with potassium of 20 mq generally diluted in 500 ml NS or RL.
  - The speed of correction is equally important and should never be bolus corrected. The most accepted rate of replacement is 10 mEq/hour. In extreme severe conditions with life threatening hypokalaemia 20 mEq/hour can be given under monitored expertise care preferably through central line.

### Which fluid to Choose?

- 0.9 % Saline: Na: 154 Cl: 154 Osm: 308.
- 0.45 % Saline: Na: 77 Cl: 77 Osm: 154.
- LR: Na: 130 Cl: 109 Lactate: 28 K: 4 Ca: 3 Osm:273.
- D5: Adds 50 gm glucose per litre, 170 kcal, 250 Osm.
- What is your goal for therapy?
  - Maintenance.
  - Rehydration.
  - Volume resuscitation.
- Any baseline electrolyte abnormalities?
  - Always Look at basic chemistry prior to ordering fluids.
- Where is the fluid going to go?
  - Hypovolemia: Primary goal is volume expansion. Use the fluid that will put the most volume into the intravascular space. NS or LR.
  - Dehydration (= Hyperosmolality): Primary goal is free water replacement. Note that this is not synonymous with hypovolemia. Use a hypotonic fluid usually 0.45% saline or D5W.

### Post-operative patients:

- Pain and narcotics can be powerful stimulants of inappropriate ADH secretion (SIADH).
- Giving hypotonic fluids in this setting can (but usually does not) cause dangerous hyponatremia.
- This makes 0.9 % saline a safer fluid but realize that it will also deliver free water in the setting of SIADH.

### There are 4 types of patients:

When considering appropriate IV fluids keep in mind that in general, there are 4 types of patients when it comes to administering IV fluids:

1. **Hypovolemic Patient:** Pneumonia, Sepsis, Haemorrhage, Gastroenteritis.
2. **Hypervolemic Patient:** CHF, renal failure, cirrhosis.
3. **NPO Patient, surgical patient, euvolemic:** Awaiting surgery, unsafe swallow.
4. **Eating/drinking normally.**

### Determining appropriate IVF:

- **Step 1: Assess Volume Status:**
  - What is the volume status of my patient?
  - Do they have ongoing losses?
  - Can my patient take oral safely?
  - Are the NPO for a reason?
- **Step 2: Determine Access:**
  - Peripheral IV.
  - Central line.
- **Step 3: Select Type of Fluid:**

Solution	Common IV Solution							
	Glucose (g/L)	Na <sup>+</sup>	K <sup>+</sup>	Ca <sup>+2</sup>	Cl <sup>-</sup>	Lactate	PO <sub>4</sub> <sup>-3</sup>	Mg <sup>+2</sup>
5% Dextrose (D <sub>5</sub> W)	50	0	0	0	0	0	0	0
10% Dextrose (D <sub>10</sub> W)	100	0	0	0	0	0	0	0
Normal Saline (NS)	0	154	0	0	154	0	0	0



D <sub>5</sub> NS	50	154	0	0	154	0	0	0
D <sub>5</sub> ½NS	50	77	0	0	77	0	0	0
0.2% NS	0	31	0	0	31	0	0	0
3% NaCl	0	513	0	0	513	0	0	0
Ringer's Lactate (LR)	0	130	4	3	109	28	0	0
D <sub>5</sub> LR	50	130	4	3	109	28	0	0

• **Step 4: Determine Rate:**

- If you are trying to fluid resuscitate that patient, you might be giving fluids “wide open” or 250 to 500 ml/hr.
- The hypovolemic patient may need multiple 1L boluses to re-establish intravascular volume. (Beware of contraindications to fluid bolus like patients of congestive cardiac failure, acute or chronic renal failure – especially anuric, or a condition wherein fluid overload will become problem)
- For others use the method:

Summary of Holiday – Segar Method		
0—10 Kg	100 ml	4 ml (~ 100/24 hours)
11—20 Kg	50 ml	2 ml
> 20 Kg	20 ml	1 ml

**Hypovolemia:**

**True volume depletion (hypovolemia):**

- Usually refers to a state of combined salt and water loss exceeding intake which leads to ECF volume contraction.
- ECF volume contraction is manifested as a decreased plasma volume and hypotension.
- Signs of intravascular volume contraction include decreased jugular venous pressure, postural hypotension, and postural tachycardia.
- Larger and more acute fluid losses lead to hypovolemic shock and manifest as hypotension, tachycardia, peripheral vasoconstriction, & hypoperfusion.

**Treatment of Hypovolemia:**

- The goals of treatment are to restore normovolemia with fluid similar in composition to that

lost and replace ongoing losses.

- Mild volume losses can be corrected via oral route.
- More severe hypovolemia requires IV therapy.
- Isotonic or Normal Saline (0.9%NaCl) is the choice in normo-natremic and mildly hyponatremia patients and should be administered initially in patients with hypotension or shock.
- Severe hyponatremia may require Hypertonic Saline (3.0% NaCl)
- In Hypernatremia patient, there is a proportionately greater deficit of water than sodium, therefore, to correct this patient you will use a Hypotonic solution like ½ NS (0.45% NaCl) or D5W.
- Patients with significant haemorrhage, anaemia, or intravascular volume depletion may require blood transfusions or colloids (albumin/dextran).
- Hypokalemia can be simultaneously corrected by adding appropriate amounts of KCl to replacement solutions.

#### Hypervolemic Patient:

- Avoid additional IVF.
- Maintain IV access with Hep-Lock (A small tube connected to a catheter in a vein in the arm for easy access. It is an alternative in some cases to using an IV. It is called hep-lock because of the order of medicating using it which is saline, medication, saline then heparin).

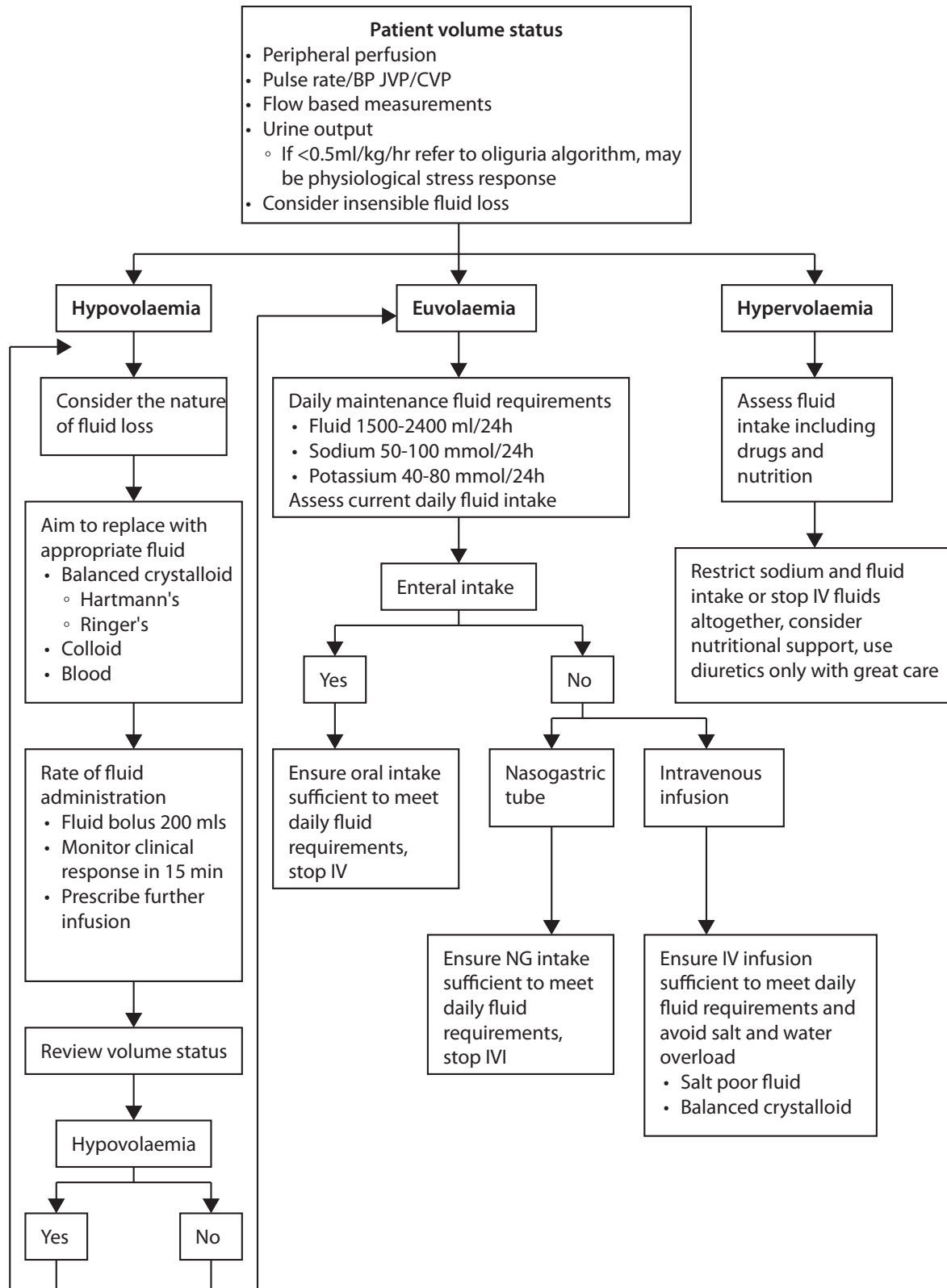
#### NPO Patient now euvolemic:

- Administer maintenance fluids. Goal is to maintain input of fluids to keep up with ongoing losses and normal fluid needs.
- For average adult NPO for more than 6-12 hours, consider D5½ NS at 75-100ml/hr.
- Constantly reassess, at least 2x day or with any change.
- Do not give fluids blindly i.e.: if the patient is pre-procedure but has history of CHF, be CAREFUL!
- The reason for giving dextrose (D5) is to prevent catabolism.

#### Normal PO Intake:

- No need for fluids if they are taking PO without problems!
- Avoid IVF

## Guideline For Fluid Therapy:

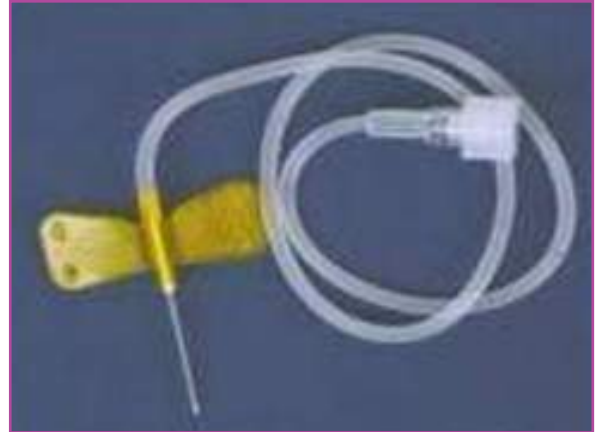


**British Consensus Guidelines  
on  
Intravenous Fluid Therapy for Adult Surgical Patients**

## Procedure:

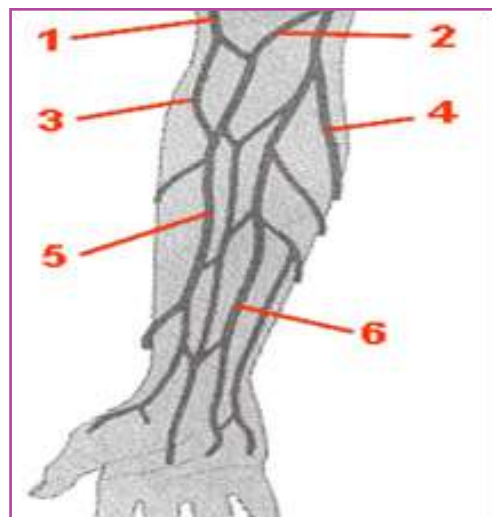
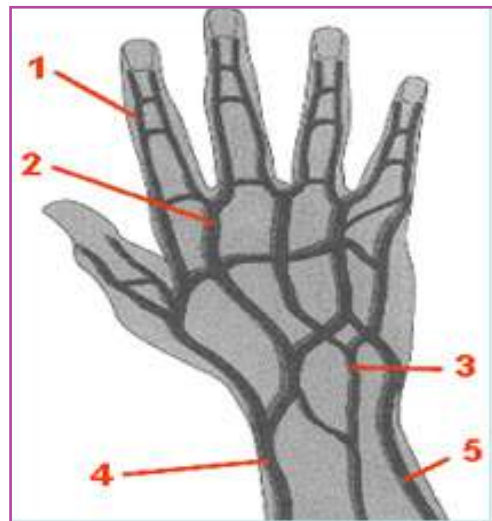
### IV Devices:

- Butterfly Catheter:
  - Deliver small amounts of medicine.
  - Infants.
- Over the Needle catheter:
  - Peripheral IV catheter.
  - Medication administration.
  - Blood transfusion



### Vein Selection:

- Veins of the Hand:
  - Digital Dorsal veins.
  - Dorsal Metacarpal veins.
  - Dorsal venous network.
  - Cephalic vein.
  - Basilic vein.
- Veins of the Forearm:
  - Cephalic vein.
  - Median Cubital vein.
  - Accessory Cephalic vein.
  - Basilic vein.
  - Cephalic vein.
  - Median antebrachial vein.

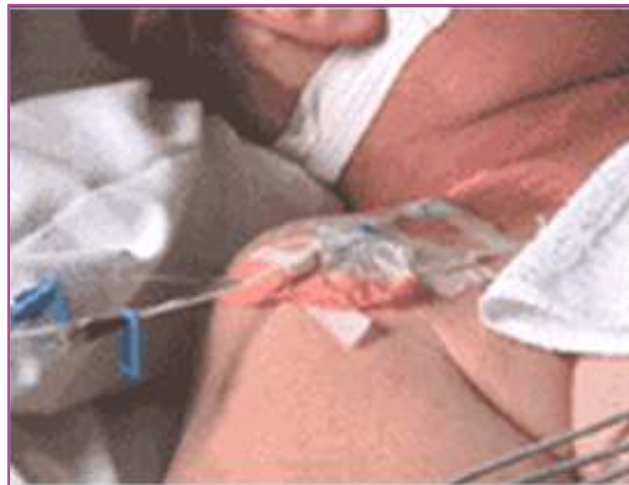


### Types of IV Lines:

- **Peripheral:** Infusion site for a peripheral is an area such as arm or hand, or rarely the leg.



- **Central:** A catheter is used to access a large vein such as the subclavian or the jugular. This catheter is threaded through the vein into the right atrium.



### Risks Of Intravenous Therapy:

#### Infection:

Any break in the skin carries a risk of infection. Although IV insertion is a sterile procedure, skin-dwelling organisms such as Coagulase-negative staphylococcus or Candida albicans may enter through the insertion site around the catheter.

- **Phlebitis:** Phlebitis is irritation of a vein that is not caused by infection, but from the mere presence of a foreign body (the IV catheter) or the fluids or medication being given.
- **Infiltration:** Infiltration occurs when an IV fluid accidentally enters the surrounding tissue rather than the vein. It is characterized by coolness and pallor to the skin as well as local oedema.
- **Fluid overload:** This occurs when fluids are given at a higher rate or in a larger volume than the system can absorb or excrete.
- **Electrolyte Imbalance:** Administering a too-dilute or too-concentrated solution can disrupt the patient's balance of sodium, potassium, magnesium, and other electrolytes.

- **Embolism:** A blood clot or other solid mass, as well as an air bubble, can be delivered into the circulation through an IV and end up blocking a vessel.
- **Extravasation:** Extravasation is the accidental administration of IV infused medicinal drugs into the surrounding tissue.

### Arterial Blood gas analysis:

- ABG is considered as one of the gold standards for assessing, diagnosing and managing a patient's oxygenation, ventilation and acid bases status in the body.
- An arterial blood which is taken in heparin flushed syringe is processed through specialised arterial blood gas analysis machine which gives immediate values related to patients oxygenation, carbon dioxide (Ventilation), bicarbonates, pH along with additional values (depending upon the machine calibre) like electrolytes to calculate the anion gap, lactate.
- With certain minute differences, venous blood gas (preferably central vein) can also be used for VBG if obtaining arterial sample is difficult. The limitations must be clearly identified.
- It is imperative that the blood sample is processed rapidly otherwise it may give altered false results if not stored and transported appropriately.
- Arterial blood gas assessment and reading it in detail is a complicated process and requires regular practice and experience to correlate it clinically, nevertheless a basic understanding of initial steps would help identify the problems at a macro level at the least. (and only these will be discussed here, for detailed analysis excellent references are available as well as the trainees can consult the mentors for bedside teaching at your training centre)
- Let's look at the important steps when
  - 1<sup>st</sup> Step: To check the Validity of ABG
  - 2<sup>nd</sup> Step: To assess the pH (normal Acidosis/Alkalosis)
    - Normal pH 7.35 to 7.45
    - Acidosis: if pH is less than 7.35
    - Alkalosis: if pH is more than 7.45
  - 3<sup>rd</sup> Step: identify the primary abnormality (Metabolic/Respiratory)
    - With the help from looking at the PCO<sub>2</sub> and HCO<sub>3</sub><sup>-</sup> values
    - If pH suggests acidosis – look at the PCO<sub>2</sub> and HCO<sub>3</sub>
    - A decreased HCO<sub>3</sub><sup>-</sup> with acidotic pH would suggest metabolic acidosis
    - A increased PCO<sub>2</sub> values with acidotic pH would suggest respiratory acidosis
    - If pH suggests alkalosis – look at the pCO<sub>2</sub> and HCO<sub>3</sub>
    - A increased HCO<sub>3</sub> with alkalotic pH would suggest metabolic alkalosis
    - A decreased PCO<sub>2</sub> values with alkalotic pH would suggest respiratory alkalosis
  - 4<sup>th</sup> Step : Look for compensation
    - Body's homeostasis mechanism will try to compensate the primary acid base disturbance by opposite mechanism. There are lot of buffer mechanisms in the body to do this.
    - A simple way to understand however is to understand that HCO<sub>3</sub> and PCO<sub>2</sub> values would move in opposite spectrum to compensate for each other. Some examples -

- In a primary metabolic acidosis where pH is acidotic,  $\text{HCO}_3^-$  levels are low the compensatory mechanism is hyperventilation trying to decrease the  $\text{PCO}_2$  values to compensate and thus we would expect the  $\text{PCO}_2$  to be lower also.

e.g. Diabetic Ketoacidosis

- In a primary respiratory acidosis where pH is acidotic,  $\text{PCO}_2$  values are high the compensatory response will be to increase the  $\text{HCO}_3^-$  levels.
- e.g COPD patients
- The rate at which this occurs will help us further classify them into acute and chronic diseases.
- Also, it is important to note that the compensations will be seen early in the disease and will start failing as the disease is progressing and body compensatory mechanisms are failing e.g. Diabetic ketoacidosis patients getting tired out and unable to hyperventilate ---- will lead to  $\text{PCO}_2$  also going up then. (even a normal  $\text{PCO}_2$  in these cases will be abnormal since normally in a compensated mode they were supposed to stay low)
- Another limitation to remember is the mixed disorders wherein the ABG may not behave in the above expected "simple arithmetic way"
- If Metabolic acidosis is there – to calculate Anion gap acidosis vs Non anion gap acidosis
- There are further, more significant steps for other complex calculations which is beyond the scope of this chapter e.g. Delta anion gaps, urinary anion gaps, etc...
- It needs to be appreciated that above represents oversimplification of a complex system, but it helps beginners to acquaint themselves with this complex but useful tool available with the clinicians at the bedside to help them guide treatment especially in sick patients.

### KEY LEARNING POINTS:

- As different types of fluids used for IV therapy, specific type of fluid can cause the shift and redistribution of body water between intracellular and extracellular compartments. Therefore, it is important to have a basic understanding of different IV fluids and choose the fluid most appropriate to the patients need.
- Administering an inappropriate IV fluid can result in undesirable complications, as well as a less than optimal partial outcome.
- Balanced crystalloid solutions are the most commonly used fluids for resuscitation as well as maintenance phase. Though even with their theoretical advantage, colloids are associated with significant adverse events and therefore are now less and less commonly used fluids (especially in critically ill patients)
- It is imperative that the Anaesthesiologist is familiar and skilled in securing a venous access in sick patient and with the basics of fluid and electrolytes therapy.

### CHECK YOUR PROGRESS:

- All IV fluids have the same impact within the body.
  - True.
  - False.
- In a fluid used for IV therapy, the sterile water into which electrolytes, proteins, or other



materials are dissolved is referred to as the

- a. Tonicity.
  - b. Solvent.
  - c. Solute.
  - d. Concentration.
- iii. Which of the following are types of IV solutions?
- a. Colloids
  - b. Crystalloids
  - c. Blood
  - d. All of the above are types of IV solutions
- iv. An IV solution contains the electrolyte sodium. Which of the following statements is true concerning the sodium?
- a. The sodium is the solution.
  - b. The sodium is the solute.
  - c. The sodium is the solvent.
  - d. All of the above are true concerning the sodium.
- v. You are administering an IV solution that contains large proteins and molecules. As such, what category of IV solution are you administering?
- a. Extravascular solution.
  - b. Crystalloid solution.
  - c. Colloid solution.
  - d. Hypotonic crystalloid solution.
- vi. The most commonly administered IV fluid given in a prehospital situation is a colloid solution.
- a. True.
  - b. False.
- vii. A crystalloid solution typically contains sterile water and \_\_\_\_\_.
- a. Proteins.
  - b. Blood.
  - c. Oxygen crystals.
  - d. Electrolytes.
- viii. Which of the following best describes a hypertonic solution?
- a. Concentration higher than the body plasma.
  - b. Concentration lower than the body plasma.
  - c. Contains less electrolytes than the body plasma.
  - d. Contains more oxygen crystals than the body plasma.

ix. Match the following IV solutions to their description:

- |                             |  |
|-----------------------------|--|
| ___ Hypertonic crystalloid. | a. Concentration the same as the body plasma.  |
| ___ Isotonic crystalloid.   | b. Concentration less than the body plasma.    |
| ___ Hypotonic crystalloid.  | c. Concentration greater than the body plasma. |

x. Identify the crystalloid solution.

- a. Hetastarch.
- b. Lactated Ringer's.
- c. Blood.
- d. Oxygen-carrying solution.

xi. The most commonly used fluids for prehospital IV therapy are:

- a. Colloids, crystalloids and blood.
- b. Lactated Ringer's, blood and 5% dextrose in water (D5W).
- c. Blood, 5% dextrose in water (D5W) and sterile water.
- d. Normal saline solution and lactated Ringer's.

xii. It is important to read the label on every IV bag because:

- a. Different IV solutions are packaged similarly.
- b. The label contains the expiry date of the IV fluid.
- c. The name of the IV solution is on the label.
- d. All of the above are reasons why the EMT should read the label on every IV bag.

xiii. The tonicity of an IV solution is described as:

- a. The amount of oxygen that it can carry to the cells.
- b. The type of water contained within the solution.
- c. The concentration of the solution as compared with the body plasma.
- d. The amount of blood contained within the solution.

xiv. As long as an isotonic solution is used, it makes no significant difference if the solution contains glucose molecules instead of electrolytes.

- a. True.
- b. False.

xv. Osmosis is the movement of water from an area of high concentration of molecules and/or electrolytes to an area containing less of a concentration of molecules and/or electrolytes.

- a. True
- b. False

#### References:

1. Brown's Department of Family Medicine Adult IVF Handout <http://www.geocities.com/brownfamilymed/>.

2. Harrison's manual of medicine, 16th ed. New York (NY): The McGraw-Hill Companies, Inc.; c2004-2005. Hypo/Hyponatremia.
  3. Harrison's principles of internal medicine, 16th ed. New York (NY): The McGraw-Hill Companies, Inc.; c2004-2005. Hypovolemia.
  4. <http://www.accd.edu/sac/nursing/math/ivprob.html>.
  5. Jeremy Powell-Tuck, Peter Gosling, Dileep N Lobo, Simon P Allison, Gordon L Carlson, Marcus Gore, Andrew J Lewington, Rupert M Pearse, Monty G Mythen. British Consensus Guidelines on Intravenous Fluid Therapy for Adult Surgical Patients. GIFTASUP. Revised 7 March 2011.
  6. Queen Mary's School of Medicine & Dentistry Prescribing Skills <http://www.smd.qmul.ac.uk/prescribeskills/>.
  7. Schwartz Principles of Surgery 7th Edition.
  8. Steve Martin's Intravenous Therapy <http://www.touchbriefings.com/pdf/14/ACF7977.PDF>.
-

# 23

## Blood transfusion, Acid base balance

### INTRODUCTION:

- Blood is a lifesaving liquid organ.
- Today`s Transfusion medicine practice aims at providing the specific component of the blood required and this process of transfusing only the portion of the blood needed by the patient is called blood component therapy.
- Whole blood transfusion has become a less common practice now.
- Blood components prepared in the blood transfusion centers consist of:
  - Red cells
  - Platelets
  - Fresh Frozen Plasma
  - Cryoprecipitate
  - Plasma derivatives such as Albumin, Coagulation factors and Immunoglobulin.
- As different blood components have different Relative Density, Sediment rate and Size they can be separated when centrifugal force is applied to them.
- Each blood component is used for a different indication; thus the component separation has maximized the utility of one whole blood unit.
- As compared to older practices, restrictive transfusion triggers are used now a days rather than liberal transfusion practices.

### LEARNING OBJECTIVES:

After going through this module, one should be able to describe the:

Learning Objective	Knowledge	Skills
Blood components and their uses and indications	✓	
Massive haemorrhage and initial resuscitation	✓	✓
Massive transfusion protocol	✓	Observe, assist in a case of massive haemorrhage if any happens during posting. Document the case to case record. Perform in simulation lab.

## HOW ARE THE DIFFERENT COMPONENTS SEPARATED?

- The Whole blood is collected as 350 ml or 450 ml in double/triple/quadruple or penta bags with CPDA-1 or additive solution. After blood collection, components should be separated within 5 - 8 hours.
- Blood is centrifuged with mainly two spins-heavy spin (e.g. 5000 G for 10-15 min) and light spin (e.g. 1500 G for 5-7 min) for separation of different components.

### What is Apheresis?

- Apheresis is an extracorporeal technique by which blood from a donor is passed through a machine that separates single/multiple components and returns the rest to the donor:
  - Plasma (Plasmapheresis).
  - Platelets (Plateletpheresis).
  - Lymphocytes (Lymphopheresis or Lymphapheresis).
  - Red blood cell.

### Red Blood Cell Component:

- Red blood cell transfusions are used to treat hemorrhage and to improve oxygen delivery to tissues.
- Transfusion of red blood cells should be based on the patient's clinical condition and patient's hemoglobin concentration combination
- RBC transfusions are used to treat hemorrhage and to improve oxygen delivery to tissues. Transfusion of RBCs should be based on the patient's clinical condition.

### Indication

- Acute blood loss of greater than 1,500 mL or 30 percent of blood volume/ongoing significant blood loss (above the allowable maximum blood loss/anticipated grade III or IV haemorrhage).
- Allowable blood loss =  
[Estimated Blood Volume \* (Initial Hb. – Final tolerable Hb.)] / Initial Hb.  
Estimated Blood Volume =   Infants: 80ml /kg  
  Adult Men: 75ml/kg  
  Adult Female: 65ml /kg
- Acute sickle cell crisis (For stroke prevention), or Thalassemia.
- Preoperative transfusion.
- Critical care patients with moderate to severe anemia.

Transfusion trigger has been changed to a threshold of 7 – 8 gm HB %. Thus a more restrictive approach of transfusion practice is accepted now-a-days rather than liberal transfusion therapy. This should be weighed according to clinical condition of patient.

### 'Rule of 30':

> 30% Blood Volume should be suspected, when:

- Pulse rate                   :   > Increases by 30 bpm.

- Respiratory rate : > 30/min.
- Systolic BP : < drops by 30 min Hg.
- Urinary output : < 30 ml/hour.
- Hematocrit : < drops by 30

Different guidelines have recommended use of a restrictive transfusion threshold of 7 to 8 g/dL. As an example, the 2016 AABB guidelines include the following recommendations for hemodynamically stable patients without active bleeding -

- Hemoglobin <6 g/dL – Transfusion recommended except in exceptional circumstances.
- Hemoglobin 6 to 7 g/dL – Transfusion generally likely to be indicated.
- Hemoglobin 7 to 8 g/dL – Transfusion may be appropriate in patients undergoing orthopedic surgery or cardiac surgery, and in those with stable cardiovascular disease, after evaluating the patient's clinical status.
- Hemoglobin 8 to 10 g/dL – Transfusion generally not indicated, but should be considered for some populations (eg, those with symptomatic anemia, ongoing bleeding, acute coronary syndrome with ischemia).
- Hemoglobin >10 g/dL – Transfusion generally not indicated except in exceptional circumstances.

#### What is response to PRBC Transfusion?

- Packed red blood cells (PRBCs) are prepared from whole blood by removing approximately 200 mL of plasma.
- One unit of packed RBCs should approximately increase levels of hemoglobin by 1 gm per dL (10 g per L) and hematocrit by 3 percent.
- 1 Unit PRBC = 300 ml with hematocrit of 60%.
- 100 ml contains 20 gm for 300 ml = 60 gm.
- In 70 kg with blood volume of 5000 ml 60 g is added.
- $100 \times 60 / 5000 = 1.2$  gm app.1gm.
- Increase in hemoglobin level is measurable 24 hrs. after transfusion. Though a new study in 2018 now mentions that determination of hemoglobin concentration 15 minutes after transfusion of packed cells accurately reflects the steady-state concentration for the next 24 hours.

#### How is PRBC Preserved?

- **Anticoagulant preservative solutions are used to prolong the shelf life of the Packed RBCs:**
  - Citrate Phosphate Dextrose-CPD: This contains Citric acid, Sodium citrate, Monobasic sodium phosphate & Dextrose which preserves the RBCs for 21 days.
  - Citrate Phosphate Dextrose Adenine: CPDA1 Preserves the RBCs for 35 days.
  - Of recent times the preservative solution ADSOL Adenine, Dextrose, Sorbitol, Sodium chloride & Mannitol maintains the viability of RBC for 6 weeks
- **Before Storage: Pre-storage leukoreduction:**
  - Removal of leukocytes by passing the blood through a leukocyte reduction filter, leaving the final leukocyte count <5 million (<5 x 10<sup>6</sup>; the FDA-required limit) and generally <1 million.
  - In most areas, Packed RBC units are filtered to reduce leukocytes before storage which limits

Febrile Non Hemolytic Transfusion Reactions (FNHTRs) and are considered cytomegalovirus safe, human leukocyte antigen (HLA) alloimmunization and in rare cases, leukocytes may contribute to transmission of intracellular bacterial organisms

- Bed side filters are now available to leuko-reduce products during the transfusion.
- **Problems of Storage: stored and transported at 1 to 10°C**
  - Storage of PRBCs leads to gradual loss of 2, 3- diphosphoglycerate leading to greater affinity of Hb for oxygen thereby reduces the oxygen delivery to the tissues.
  - Red cell changes
    - Depletion of ATP
    - Membrane changes
    - Increased oxidative damage to lipids and proteins
    - Loss of deformability
  - Potassium leaks out of the cell.
  - Decreases in nitric oxide (NO)
  - Gradual buildup of lactate.
  - Cells die & get haemolysed.

#### What is meant by Irradiated RBC?

- Gamma irradiation of 2500 cGy is used to inactivate the lymphocytes in a unit of packed cells that are responsible for transfusion associated graft versus host disease. Irradiated RBCs have a storage limit of 28 days post irradiation.

#### What are Leucocyte depleted Red Blood Cells?

- Leucocyte depleted Red Blood Cells have had 99.9% of white cells removed by freezing or microfiltration. (already mentioned in pre storage leukoreduction)
- Thereby reducing the risk of Cytomegalovirus, Epstein-Barr, HTLV infection & Febrile reactions. (already mentioned above)

#### Leucocyte depleted Red Blood Cells Advantages: (already mentioned above)

- Leucocytes the blood products can induce adverse effects during transfusion, mostly febrile non haemolytic reactions.

Bed side filters are now available to leuko-reduce products during the transfusion.

#### What are washed RBC & its Uses?

- Using a special machine RBCs are washed 3 times with 0.9% saline.
- This process removes Plasma proteins, Platelets, WBCs & Microaggregates which may cause febrile or urticarial reactions. The shelf-life of washed blood is four hours at 20 to 24°C or 24 hours if stored at 1 to 6°C.

#### Volume-reduced red cells —

When circulatory overload is a concern (e.g., due to congestive heart failure, renal failure), the RBC unit can be centrifuged immediately prior to transfusion to remove the storage solution and hence reduce the volume of the transfusion.



## Platelets:

- Platelets are Non-nucleated, Smooth, Disc-shaped cellular fragments.
- That are produced by 'Budding off' from megakaryocytes in the bone marrow.
- They measure 2 - 4 micrometers in diameter.
- Circulatory life span is of 8 - 14 days.
- Normal Values: Adult 200 - 300,000/cumm.
- Platelets are required for primary haemostasis.
- By the release vasoconstrictors (e.g., thromboxane A2 and serotonin), are involved in the initiation of coagulation and are essential for retraction of the final clot.
- Through a series of reactions occur inducing platelet adherence to vessel walls and platelet activation leading to platelet aggregation and formation of a primary haemostatic plug.

### Available:

- Random Donor Platelets.
- Single Donor Platelet (SDP).

### Random Donor Platelets:

- Platelets are prepared by centrifugation of plasma and removal of the platelet-poor component.
- Process yields a unit of approximately 50 ml and is termed random donor platelets.
- Four to six of these units are nearly always pooled prior to transfusion.

### Single Donor Platelets (SDP):

By apheresis process called Plateletpheresis, platelets are separated from whole blood at the time of donation and the remainder of the blood is transfused back to the donor. This is called Single Donor Platelet (SDP).

### Advantages of Single Donor Platelets (SDP):

- Less antigen exposure and a longer - Lasting increase of the platelet yield in 1 units DP of 200-500 ml.
- One SDP contain a min of  $3.0 \times 10$  lakhs Platelets.
- Of 1 unit D = P 4 - 6 units of Random Donor Platelets.
- 3 Single Donor units from 1 donor can be obtained during 1 Apheresis session.

### What are pooled Platelet?

- This is a two-step procedure.
- 1 unit of platelets is produced from a unit of Whole blood.
- Then, 4-6 of these units (From different donors) are 'Pooled' together in a single pack.

### How platelets are stored?

- Platelets are stored at room temperature (20 - 24°C) with gentle agitation for 5 days.
- The purpose of the agitation is to prevent platelet packing and increase oxygenation of platelets.

### Blood Group & Cross Matching needed for Platelet Transfusion:

- Platelets contain the ABO Antigens; however, the concentration is only about 5% of that in RBCs.
- Recipient anti-A or anti-B antibodies may affect platelet survival, but should not cause a harmful reaction to the patient.
- It is acceptable practice to administer unmatched Platelet.

### Is Cross Matching Necessary:

- Platelets express ABO antigens on their surface, as well as HLA class I antigens. They do not express Rh or HLA class II antigens therefore a mismatch should have no effect on platelet survival, but Always Rh-negative Women of child-bearing age should receive only Rh-negative platelets to prevent Isoimmunization because platelets do contain a small number of RBCs that can be Rh positive.

### Alloimmunisation & Platelet Transfusion:

- HLA class-I antigens are present on the WBCs in the platelet unit.
- Transfusion, especially with pooled-platelets (Multiple donors), leads to alloimmunization to the HLA antigens.
- In Subsequent platelet (and other component) transfusions, these antibodies possibly deem the patient refractory to platelet transfusion.

### Indications for Platelet Transfusion:

- In stable patients, a count of less than 10,000/ cu mm.
- In febrile patients, a cutoff of 20,000/cu mm can be used.
- Bleeding patients or those undergoing surgery or an invasive procedure can be transfused when their platelets are less than 40,000 - 50,000/ cu mm.
- Platelet count of should be 50,000/cumm of blood for procedures like Lumbar puncture, Epidural Anaesthesia, Upper gastrointestinal endoscopy, Transbronchial biopsy, Laparotomy.
- For surgeries involving the eyes and brain the trigger should be 100,000/cumm.

### Dosage of Platelets:

- One random unit of platelets increase the platelet count in an adult by 5,000 - 8,000/cumm.
- In children, 0.1 - 0.2 units/ kg will increase the platelet count by 30 - 50,000/cumm.
- The expected increase will be less if the patient has sepsis, splenomegaly, and platelet auto - or allo antibodies or is receiving chemotherapy.
- The dose of platelet is one RDP/ 10 kg of body Weight i.e. 4-6 RDP (one SDP) for an adult and 10-15 ml/kg for children.
- The same should be transfused rapidly over 30 minutes; in paediatric patients the rate should be 20-30 ml/kg/hour.

### Storage period for Platelet:

- Recommended storage period is 5 days; beyond this risk of bacterial-overgrowth is very high. Platelet preparations are never to be kept in refrigerator.
- All the platelet preparations should be gamma irradiated before transfusion with a minimum

dose of 25 Gy or otherwise bedside platelet filters should be used.

### Why Bacterial Infection is a Serious Complication of Platelet Transfusion?

- Bacterial infection is a serious complication of platelet transfusion which is stored for more than 3 days.
- Reasons are: Bacteria can enter from donor skin at the time of collection.
- Platelet stored in oxygen permeable bags at  $-2-20^{\circ}$  C helps to preserve platelet function but encourages bacterial overgrowth.

### Fresh Frozen Plasma:

- Plasma from a person with Blood Group A is type A plasma; it contains antibodies to the B antigen.
- Plasma from a Group O person contains antibodies to A and B, so its use is restricted to type O recipients.
- Group AB+ plasma is the “universal donor” plasma.

### What are the Different Types of Plasma Available?

- Fresh Frozen plasma (FFP): Plasma frozen at  $-180^{\circ}$ C or colder within 6 hours of donation.
- F24 Plasma: Plasma frozen at  $-180^{\circ}$ C or colder within 24 hours.
- Cryo Supernatant or Cryo-reduced Plasma (CRP): when FFP thawed at  $40^{\circ}$ C; once collected it is refrozen at  $-180^{\circ}$ C or colder.
- Solvent-detergent Treated Plasma.
- Liquid Plasma: Plasma not immediately frozen as FFP or F24 and stored at  $-160^{\circ}$ C.

### Shelf life of FFP:

- When stored at  $-18^{\circ}$ C or below, FFP outdates in 12 months proper storage - Minimal loss of coagulation factor activity including labile factors V and VIII.
- Prior to administration FFP is thawed at  $30-37^{\circ}$  C in an FDA cleared thawing device.
- If thawed in a water bath, a protective wrap is used to prevent contamination of the ports on the unit. Thawed FFP is stored at  $16^{\circ}$  C and must be infused within 24 hours of thawing.

### Indication:

- FFP is the product of choice for patients specifically requiring replacement of the labile clotting factors or other proteins.
- The effect of plasma transfusion on the PT and INR is 4 to 6 hours owing to the short half-life of coagulation factor VII. Thus other, longer-lasting means of restoring coagulation factors, such as vitamin K administration, should be undertaken.
- When replacing coagulation factors with plasma, it is not necessary to have 100% factor replacement as the goal.
- Haemostasis is typically able to occur if circulating coagulation factor levels are between 40% and 50%.
- It is important to understand that the relationship between the INR and the percentage factor level is a logarithmic, rather than a linear, relationship. Thus, Whether the INR is 9 or 1.8 the initial dosage of plasma should be 10 to 20 ml/kg, with recheck of the laboratory values a few minutes

after infusion. The more prolonged the INR, the more significant the impact of the dose on the INR.

#### What is the dose of FFP?

- Fresh frozen plasma should be given in doses calculated to achieve a minimum of 30% of plasma factor concentration (Usually achieved with administration of 10 - 15 ml/kg of FFP), except for urgent reversal of warfarin anticoagulation, for which 5-8 ml/kg of FFP is usually enough.

#### What are Other Products of Plasma?

- Albumin.
- Immunoglobulins.
- Hyperimmune Serum.

Albumin is available in Three Forms: 5%, 25% and Purified protein fraction.

Intravenous Immunoglobulins- Clinical use is in Acute Immune Thrombocytopenia Guillain-Barre syndrome, Autoimmune Haemolytic Anaemia etc.

Hyperimmune Serum Hyperimmune serum is prepared from large pools of plasma known to contain elevated antibody titers against specific Infectious agents.

#### Cryoprecipitate:

- Cryoprecipitate, which contains Factor VIII, Fibrinogen, Fibronectin, Von Willebrand's factor (VWF) and Factor XIII, is used for the correction of inherited and acquired coagulopathies.

#### Dose Cryoprecipitate:

One unit of cryoprecipitate per 10 kg body weight raises the plasma fibrinogen concentration by approximately 50 mg/dl in the absence of continued consumption or massive bleeding.

#### How Cryoprecipitate is prepared?

- Cryoprecipitate is prepared from one unit of FFP thawed at 40°C and the precipitate is then refrozen in 10- 15 ml of plasma and stored at -1 8°C or colder.

#### What are the Contents of cryoprecipitate?

- One unit of cryoprecipitate is 15 mL. Cryoprecipitate contains at least 150 mg of fibrinogen and at least 80 IU of factor VIII.
- These represent 20%-40% of the fibrinogen and 50% of the factor VIII of the original unit of plasma. Von Willebrand factor is another important component of Cryoprecipitate.

#### What are the Indications for Cryoprecipitate?

- It is predominantly used to treat F XIII deficiency and fibrinogen deficiency. However, in India due to non-availability and high cost of factor VIII concentrate it has been used for factor substitute in haemophilia and von Willebrand's disease.

#### Main Indications are:

- When the fibrinogen concentration is less than 100 mg/dl in the presence of excessive

microvascular bleeding.

- To correct excessive microvascular bleeding in massively transfused patients when fibrinogen concentrations cannot be measured in a timely fashion.
- For patients with Von Willebrand's disease and Congenital fibrinogen deficiencies.

#### How Cryoprecipitate is administered?

- ABO compatibility is suggested, but not required for Cryoprecipitate transfusion. Thawed cryoprecipitate is given as soon as possible after thawing. The cryoprecipitate is mixed well with 10-15 ml of 0.9% Sodium Chloride.

#### Donated Blood and its processing:

- Donated blood is tested prior to distribution for transfusion.
- Blood is typed including ABO and Rh type.
- Testing is also performed for Human Immunodeficiency Virus, Hepatitis C Virus, Human T-cell Lymphotropic Virus, Hepatitis B core Antigen, Hepatitis B Surface Antigen, HCV RNA, HIV-I RNA and Syphilis.

#### Transfusion of Blood Products:

- Transfusion of Whole blood and all blood components must be transfused through a filter designed to remove clots and aggregates (170-um blood filter) without any other medications or solutions. Preferably they should be used separately for separate products
- Lactated Ringer's or other solutions containing calcium should never be used with blood transfusions.
- Blood may be warmed prior to administration for exchange or massive transfusions or for patients with cold-reactive antibodies.
- The initial administration of blood is very slow should a life-threatening reaction occur. Transfusion should be completed within four hours and prior to expiration of the blood product.

#### What are the Immunologic Complications of Transfusion?

- Immunologic complications of transfusion may be immediate.
- In Haemolytic transfusion reaction, transfused red blood cells are destroyed by haemolysis due to incompatibility of antigen on transfused cells with antibody in the recipient's circulation.
- Allergic reactions usually occur with urticaria, wheezing, and angioedema. anaphylactoid reactions are dangerous complications of transfusion and consist of autonomic dysregulation, severe dyspnea, pulmonary and/or laryngeal edema and Bronchospasm. Transfusion-related Acute lung injury occurs with pulmonary leakage of fluid into the alveolar and interstitial spaces.
- Febrile non haemolytic reactions occur with about 1% of transfusions. This reaction is manifested by a temperature elevation of  $>1^{\circ}\text{C}$  or  $2^{\circ}\text{F}$  after transfusion without other cause of a fever. Such patients are often treated by Leukocyte-reduced packed red blood cell transfusions.
- Immunologic reactions may also be delayed. Delayed haemolytic reaction may occur. Alloimmunization to red blood cell antigens may occur days or weeks after transfusion. Post-transfusion purpura may cause sudden thrombocytopenia 7-10 days after transfusion. Graft-vs-host disease (GVHD) occurs when T lymphocytes react against tissue antigens in the recipient.

## Massive haemorrhage and Massive Transfusion protocol (MTP)

Major haemorrhage:

Definition

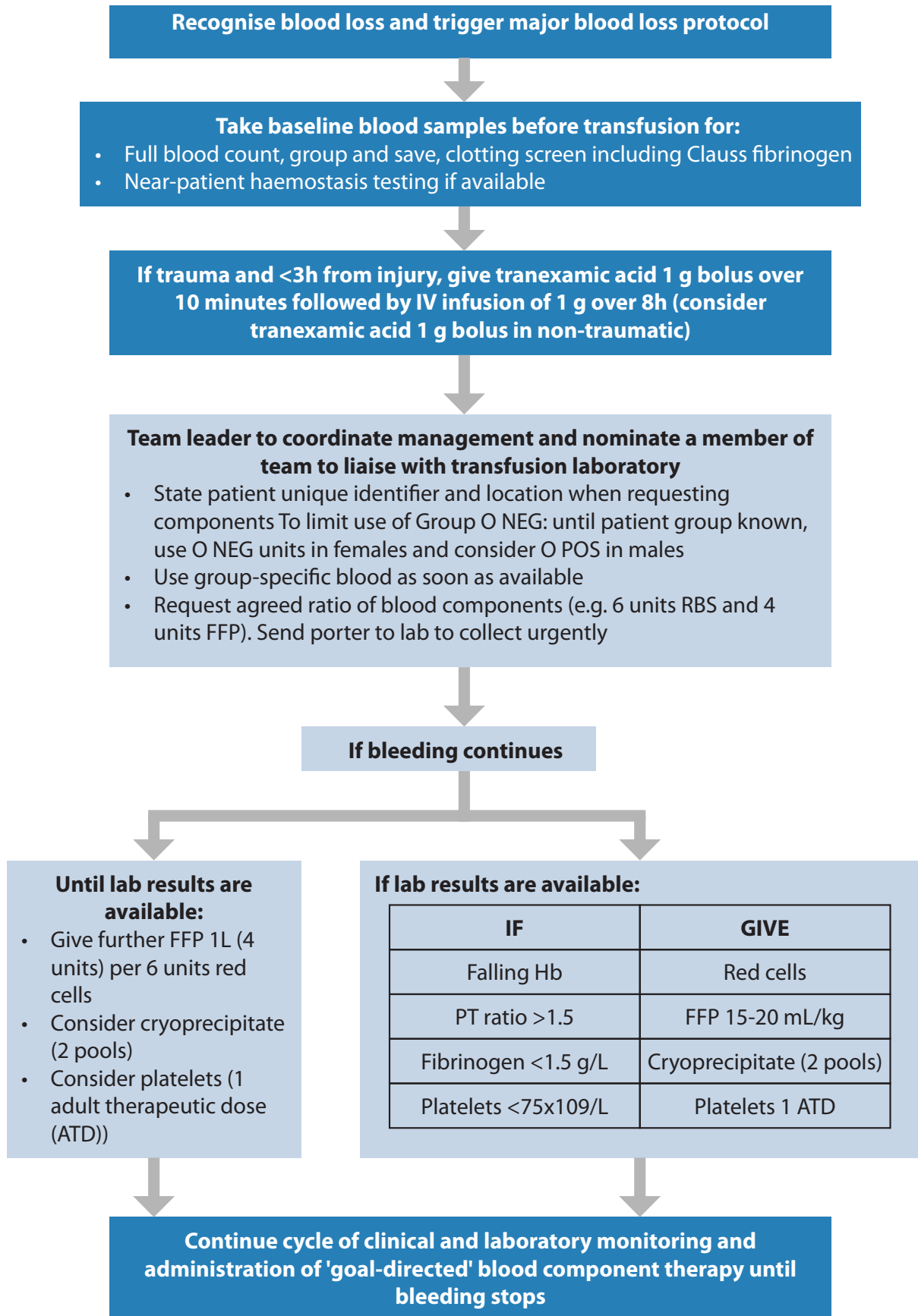
1. 50% of total blood volume is lost in less than 3 hours
  2. Loss of more than one blood volume of the patient within a span of 24 hours
  3. Bleeding in excess of 150ml/minute for an adult patient
- Early recognition and appropriate prompt management is essential in survival of these patients along with a coordinated multidisciplinary team work, preferably protocol driven.
  - The essence of treatment lies on early identification, early hemostasis (control of bleeding with surgical &/or interventional radiology) along with ongoing damage control resuscitation with IV fluids, Blood and blood products, tranexamic acid and supporting pharmacotherapy along with the ABCDE management of emergency condition.
  - Treating with appropriate, up-to-date evidence based use empirical blood and blood products in appropriate ratio with care taken to prevent - recognize – treat the complications of blood transfusion, especially massive blood transfusion cannot be overemphasized.
  - It is important to appreciate the Lethal triad of trauma – which is also applicable in significant obstetric haemorrhage i.e. Acidosis, Coagulopathy and Hypothermia. As the name itself implies, this clinical triad when present will cause significant increase in morbidity and mortality in a given patient.
  - It is imperative that while definitive hemostasis and resuscitation is going on, the treating doctor keeps in mind the possibility of occurrence of lethal triad especially during massive blood transfusion and takes measures to identify and prevent them.
  - The essence of massive blood transfusion protocol lies in the following key steps:-
    - Identification of a condition where the need for MTP would be needed
    - Activating the MTP protocol
    - Multidisciplinary and coordinated protocolized team work
    - Surgical team aims for definitive haemostasis measures
    - ABCDE management
    - Ongoing damage control resuscitation
    - Large bore IV cannulas
    - Blood sample collection – CBC, Blood group, Cross match, Coagulations screen (PT, APTT & INR) Kidney function test including electrolytes. Desirable, if can have results for fibrinogen levels and POINT OF CARE ( POC) tests for coagulation also.
  - IV non dextrose containing warm Crystalloids infusion (RL or NS). To aim for urgent replacement of blood loss by blood and blood products rather than IV fluids to prevent dilutional coagulopathy.
  - Till Laboratory results are awaited, empirical transfusion of blood and blood products in a predefined specific ratio. Though many different ratios have been studied for PRBC: FFP: Platelets, one of the most common and accepted initial ratio for empirical transfusion till availability of lab results is 1:1:1 ( see the difference in the below guideline showing another accepted strategy).
  - PRBC:
    - Red Cell transfusion is usually necessary in grade III and Grade IV shock. It is important to realize that at times peripheral blood hematocrit and the measure Hb values might

be misleading early after a major haemorrhage and clinical observation should make an important part in decision making.

- For immediate transfusion, O -ve blood group can be used initially. Once available ABO Rh specific cross matched PRBC can then be transfused
- FFP and other coagulation measures in Major haemorrhage:
  - Transfusing large volume of PRBCs and IV fluids which doesn't have platelets or coagulation factors while the Whole blood is lost in the haemorrhage creates an state of dilutional coagulopathy.
  - Additionally hypothermia, acidosis and hypocalcemia (because of rapid blood transfusion ionized hypocalcemia can become a threat) impairs the coagulation further.
  - Plasma fibrinogen levels are helpful in assessing this, as is the coagulation screening test like PT APTT INR or the point of care tests.
  - Empirical transfusion of FFP helps in the massive haemorrhage treatment while awaiting lab results when more specific lab result directed product therapy can then be utilized.
- Platelets:
  - Thrombocytopenia may develop after massive haemorrhage. Generally, the platelets value drop significantly after around a blood loss of approximately 5 litres but then this might be also more significant even in lesser volumes especially considering consumptive coagulopathy, HELLP syndrome or otherwise.
  - Many empiric regimens don't always consider immediate transfusion of platelets while some regimes consider transfusing PRBC : FFP : Platelet of 1:1:1
  - Platelets have a low shelf life and availability of platelets is not always as easy as PRBCs and FFP.
- Tranexamic acid 1gm iv Bolus over 10 minutes followed by 1gm infusion over 8 hours is recommended in major haemorrhage. This is to be given if only can be started within 3 hours of haemorrhage onset.
- Continuous monitoring of Vitals and ongoing ABCDE appropriate treatment is must along with subjective and objective signs of adequacy of haemoglobin and coagulation status.
- At the earliest feasible time interval, the empirical ongoing blood products replacement should be changed with lab and clinical guided treatment.

Please find below one of the suggested protocols for massive haemorrhage treatment through massive transfusion protocol. It will be appreciated that the ratio is different than 1:1:1.





Algorithm for the management of major haemorrhage (adapted from the BCSH Practical Guideline for the Management of Those with, or at Risk of Major Haemorrhage (2014).

## KEY LEARNING POINTS

- Blood transfusion practices are important part of management of obstetric conditions and Anaesthesiologist plays an important role perioperatively in guiding blood transfusion treatment.
- In recent times with changing evidence current strategy adapted is of restrictive transfusion policy based on trigger thresholds and clinical condition accordingly rather than liberal transfusion policies used in the past.
- Rather than using the whole blood, the focus is more on giving targeted blood products rather than whole blood in itself e.g. packed red blood cells for anemia, FFP/ cryoprecipitate for loss of certain coagulation factors or prolonged prothrombin time associated coagulopathy (if not therapeutic), platelets for clinically significant thrombocytopenia and so on.
- It is important that the whole multidisciplinary team is well versed and trained with the massive haemorrhage identification, early management including definitive haemostasis methods and massive blood transfusion protocols (empirical followed by lab and clinical directed specific product transfusions).

## CHECK YOUR PROGRESS:

Q1. What are the blood components and mention their indications?

Q2. In a patient without heart disease and ongoing blood loss with no other comorbidity, the transfusion threshold for Hb accepted now a day is

- a. Hb of 6gm%
- b. Hb of 7 to 8gm%
- c. Hb of 10gm%
- d. Transfusion trigger cannot be defined

Q3. In a patient with bleeding with INR of 1.8, the most appropriate blood product to transfuse from the following to halt/reverse the coagulopathy would be

- a. whole blood (within 35 days from collection).
- b. FFP.
- c. Platelets.
- d. Empirical transfusion of 1:1:1 (blood / FFP / Platelets).
- e. None of the above

Q4. Write short note on platelet collection, transfusion practices and side effects

Q5. Define massive haemorrhage. Describe its management including massive transfusion protocol.

## References:

1. Millers Anesthesia 9th edition
2. BCSH Practical Guideline for the Management of Those with, or at Risk of Major Haemorrhage (2014).

# Week 7 - Module

## PACU & Complications



# 24

## Pain Relief

### INTRODUCTION:

- A good pain relief is an important component of a comfortable and safe labour.
- If we trace the history of recent times of analgesic provided during the childbirth in the history, it can be probably traced back to 1847 with the application of ether and later chloroform. Since then things have changed significantly.
- A broad classification to approaching labour analgesia is classification into pharmacological and non-pharmacological ways of pain relief.

### LEARNING OBJECTIVES:

After going through this module, one should be able to describe the:

Learning Objective	Knowledge	Skills
Importance of treating labour and perioperative pain and broad approaches. Pain pathways	✓	
Non pharmacological and pharmacological approach to manage labour analgesia	✓	✓ Observe, assist and prescribe Analgesia to pregnant patients in labour management under supervision. Note in the logbook.
Pharmacological approach to managing perioperative pain. Indications and side effects	✓	✓ Observe, assist and prescribe Analgesia to pregnant patients in perioperative setup (LSCS) management under supervision. Note in the logbook.

## ANALGESIA FOR SPONTANEOUS VAGINAL DELIVERY:

- The International Society for the Study of Pain describes pain as “an unpleasant sensory and emotional experience associated with actual or potential tissue damage or described in terms of such damage.
- Labour Pain: one of the most intense pain.
- Side effects:
  - Pain causes maternal hyper ventilation. Shifts ODC to left -Decreases oxygen delivery to foetus - Hyper is followed by hypo ventilation between uterine contractions - Foetus hypoxia.
  - Pain increase catecholamine
  - Excessive skeletal muscle activity produces lactic acidosis. Maternal metabolic acidosis.
  - Hypertensive response to pain may be detrimental to mother as well as foetus.

## PAIN PATHWAY:

- **During First Stage:**
  - Pain impulse arises from the uterus due to contractions causing ischemia.
  - In addition, stretching and distention of the lower segment and cervix may stimulate mechanoreceptors.
  - This stimulus enters the cord at T10, T11, T12 & L1 spinal segments.
- **During Second Stage:**
  - Stretching of perineum causes pain transmitted through S2, S3, S4 nerve fibers.
  - In addition, it is widely believed that the low back pain which is mostly experienced during the pregnancy at least partially may be explainable by the referred pain from the nerves originating in the Corpus uteri and the Cervix, which actually ends in the dorsal horns of T10 to L1/2 segments and thus is an extension of visceral pain.
  - Women with low back pain or intermittent additional continuous backpain as addition to the intermittent low back pain reports one of the highest levels of pain (more than abdominal contraction pain).

## PAIN ASSESSMENT AND PERCEPTION OF WOMEN UNDERGOING DELIVERY:

- Cultural values play a major role in management of labour analgesia. Though not conclusively proved, its widely believed that many women accept the notion of experiencing through the childbirth pain (at least partially or whatever is tolerable) as routine.
- Many are however not aware about the options available to have pain relief.
- It is also more often than not that the women are not many a times involved in the decision making process of pain treatment in labour or in perioperative pain pathways because of many reasons (social, ignorance both on the part of patient as well as health care workers, resources, lack of monitoring facilities or expertise required , etc..)
- Pain assessment can be done by many of the accepted methods which are validated across different healthcare scenarios, one being Visual analog scale rating the pain from 1 to 10.
- Though widely used, it might be still misleading in the obstetric labouring patients, probably for the reasons mentioned above. The pregnant patient despite having moderate to sever pain



might still be dealing and feeling not helpless or distressed.

- In such scenarios, a furthermore good assessment of pain might be to ask the labouring parturient to rate the “coping mechanism of pain” on a 10 point scale --- e.g. “Please answer that on a scale from 0 to 10, zero being absolutely no problem with coping and 10 being impossible to cope with the pain, how well are you Coping with the labour pain currently”?

## **BASIS OF A COMFORTABLE DELIVERY IN TERMS OF PAIN RELIEF: ALL PARTURIENT SHOULD BE ABLE TO**

- Participate in the decision-making process about the plan of birth care which includes adequate shared knowledge about pain relief options
- Access a labour suite wherein the parturient can move and have a safe, secure and comfortable birth place option.
- Have support of one or two people (which will be socially and culturally appropriate as well as take care of norms of labour room suite and not cause discomfort to other patients) who can comfort the parturient emotionally and physically.

## **HOW TO APPROACH TO ISSUE ?**

- Non-pharmacological methods of some sort which are easily available and practicable should be employed for the longest duration possible during the process of labour.
- Whenever requested for, some pharmacological options should be easily available at the health care setup which can be practiced safely in the given facility. The resources in terms of equipment for intervention as well as monitoring should be available for given pharmacological intervention. It is also important that the treating doctor is familiar in the use of such pharmacological intervention.
- Depending upon the resources available, the pharmacological and non-pharmacological interventions can be divided into low resource, intermediate resource and high resource requiring intervention.
- Low resource interventions are easy, safe most of the times, easily available but doesn't have high potency however, can be practiced easily.

## **NON PHARMACOLOGICAL INTERVENTIONS EASILY POSSIBLE ARE:**

- **Low Resource non pharmacological interventions**
  - Antenatal Education:
  - Psychological preparation of labour.
  - Deep breathing exercise (Lamaze technique).
  - Knowledge about pain relief.
  - Hand holding and soothing by near and dear ones
- **Moderate and high resource non pharmacological interventions are**
  - Aroma Therapy
  - Acupuncture
  - Sterile water injection

- Biofeedback
- Transcutaneous electrical nerve stimulation.
- Low resource non-pharmacological interventions should be used either singly or in combination and their use should be encouraged in the healthcare facility

## PHARMACOLOGICAL APPROACH:

- Can be broadly divided into following three
  - **Systemic Analgesics**
    - Opioids
    - Acetaminophen
    - Inhalational – Entonox
    - Anaesthetic like Ketamine (Rare)
  - **Local Blocks**
    - Pudendal nerve block
    - Paracervical Blocks
  - **Neuraxial**
    - Epidural
    - Single shot spinal
- For a low resource setup, systemic opioid analgesics in moderate doses with attention to side effects is the best way to proceed.
- Resource intensive interventions like PCA pumps, Entonox delivery system or interventions which requires special training and setup like neuraxial anaesthesia are not feasible to practice at resource limited setup and should not be attempted without necessary expertise and equipment. (They are mentioned here for the sake of completion of topic and understanding)

## A. Systemic Analgesic Techniques:

- The easiest way to administer pharmacological intervention as pain relief modality in perioperative period and labour analgesia.
- While the following discussion holds true in terms of labour analgesia, they can be used more liberally in operative procedures once the baby is delivered. Though chances of drug transmission remain a real concern through breast feeding, however the drug level transferred is real low and the benefit for relieving maternal pain surpasses the harm most of the times.
- **Opioids:**
  - Route: Oral, Intramuscular, Intravenous. (PCA route even though systemic requires lots of resources).
  - Drugs:
    - Pentazocine: 0.4-0.6mg/kg –



- easily available, ceiling effect
- Tramadol: 1-2mg/kg IV, --
  - easily available, anti-shivering effect also is there
  - Should not be used in patients with seizures (Eclampsia)
- Fentanyl 0.5 to 2microgram/kg. (IM / IV)
  - Short acting (more suitable for PCA pump)
  - Highly potent
  - Respiratory depression easy with higher doses
  - Narcotic license required to prescribe the drug
- Advantages:
  - Easy to administer as compared to more invasive procedures
  - Produces mild to moderate relief in pain
- Side effects:
  - Nausea, Vomiting, Pruritus,
  - Respiratory depression in neonates.
  - Not very potent, might not result in complete pain relief.
- **Non-opioid Analgesics**
  - Nonsteroidal Anti-inflammatory Agents: Not preferred during labour analgesia since there is a risk of premature duct closure in the newborn.
  - However, can be considered in perioperative care once the baby is delivered. Side effects including Gastric acidity, rare chances of kidney injury additionally.
  - Acetaminophen can be prescribed either orally or in IV infusion special preparations but are not widely used since the potency is very low.
- **Patient Control Analgesia (Intravenous) PCA Device:** Programmed to deliver fixed amount of drug when patient demands.
  - Advantages: Patient gets immediate analgesia whenever she wants.
- **Ketamine:**
  - 0.5 - 0.6 mg/kg not more than 1 mg/kg in 30 mins.
  - Not used rarely because of the non-familiarity of the drug use as well as potential side effects.
  - Side effects:
    - Hypertension and tachycardia.
    - Delirium
    - Raise in pulmonary arterial pressures.
- **Inhalational Methods:**
  - Entonox: 50:50 (N<sub>2</sub>O:O<sub>2</sub> Mixture).

- Parturient may use Entonox at early onset of contraction and discontinue at peak of contraction.
- Specialized instrument needed to deliver the mixture and avoid potential complications  
Side effects:
- Dizziness, Nausea, Dysphonia, Lack of cooperation.

## B. Regional Analgesia Technique:

### 1. Single Dose Neuraxial Opioids:

Single dose of opioids in spinal or epidural anaesthesia

- Fixed duration of analgesia
- Smooth transition from post-operative period
- Drugs: Pethidine, Tramadol, Buprenorphine, Morphine, Fentanyl.
- Side-effects: Nausea, Vomiting, Pruritus, Respiratory depression, Urinary retention.

### 2. Continuous Epidural Analgesia:

- Epidural catheter.
- Drugs: Local anaesthetic agents - alone Bupivacaine,
- Local anaesthetic +Opioids (Buprenorphine, Fentanyl, Tramadol), Opioids diluted with normal saline. Catheter can be kept for 4-5 days.
- Side-effects: Nausea, Vomiting, Pruritus, Urinary retention, Respiratory depression, Hypotension.

### 3. Patient Controlled Epidural Analgesia:

- Epidural catheter is inserted.
- PCA is attached to the epidural catheter.
- Whenever patient wants pain relief, she pushes button and fixed amount of drug delivered through catheter.

### 4. Local Nerve Blocks:

Ilio-hypogastric, Ilioinguinal, Intercostal., TAP for post LSCS

Pudendal and paracervical blocks for labour analgesia.

Paracervical blocks are almost abolished in use because of high incidence of foetal bradycardia

### 5. Wound Infiltration:

## KEY LEARNING POINTS:

- Maternal request alone is a good enough reason to give labour analgesia
- Low resource non-pharmacological interventions, even though has less potency comparatively, however, can be utilized more frequently and effectively via proper training and change in

protocols.

- Pharmacological interventions include systemic drug administration (either enterally / parenterally or inhalation ally), local regional blocks and neuraxial options.
- Though neuraxial analgesic is one of the most potent options with least effect on mother and baby, it is not without complications especially when practice in a poor setup and by an inexperienced team.
- Systemic analgesics – especially opioids are one the most feasible and comparatively safe options, Attention to side effect of the drug on mother and child needs to be paid attention to and measures taken to ameliorate these effects.
- While posting in wards for training, it is essential that the methods and drugs used are keenly observed and learned under supervision.

### **CHECK YOUR PROGRESS:**

Q1. Importance of pain relief in Parturient.

Q2. Approach to labour analgesia in a parturient. Classify the methods of pain relief in short.

Q2. Non-Pharmacological approach to pain pathway relief in labour analgesia. Write a short note.

Q3. Pharmacological Approach to pain pathway in labour pain. Classify the options available. Write in brief about systemic Analgesia approach and available options.

# 25

## Anesthesia records keeping

### INTRODUCTION:

- Anaesthesia record keeping is an important aspect of clinical management when giving anaesthesia to the patients. It keeps the documented charting of whatever has happened to the patient peri-operatively and is in records even years after the procedure has been completed.
- Depending upon the way, the anaesthesia records are understood and actually documented in the case file of the patient, the record can turn the Anaesthesiologists best friend when written properly or worst nightmare if incomplete and bizarre documentation is done.
- As the dictum says whatever is on the paper is only accepted in the court of law. And thus, a proper documentation is an important medico legal requirement while treating any case. In this chapter we will see orientation towards the various basic record keeping documents used in Anaesthesiology.

### LEARNING OBJECTIVES:

After going through this module you should be able to describe the:

Learning Objective	Knowledge	Skills
To understand the importance of Anaesthesia Record keeping	✓	
Components of Anaesthesia record keeping documents	✓	
Pre Anaesthesia Check-up (PAC) record sheet Informed written consent Surgical safety checklist Intraoperative monitoring sheet Postoperative recovery notes	✓	✓ Fill up PAC sheet, takes and documents consent, surgical safety checklist Intra-operative sheet, Postoperative instructions and notes

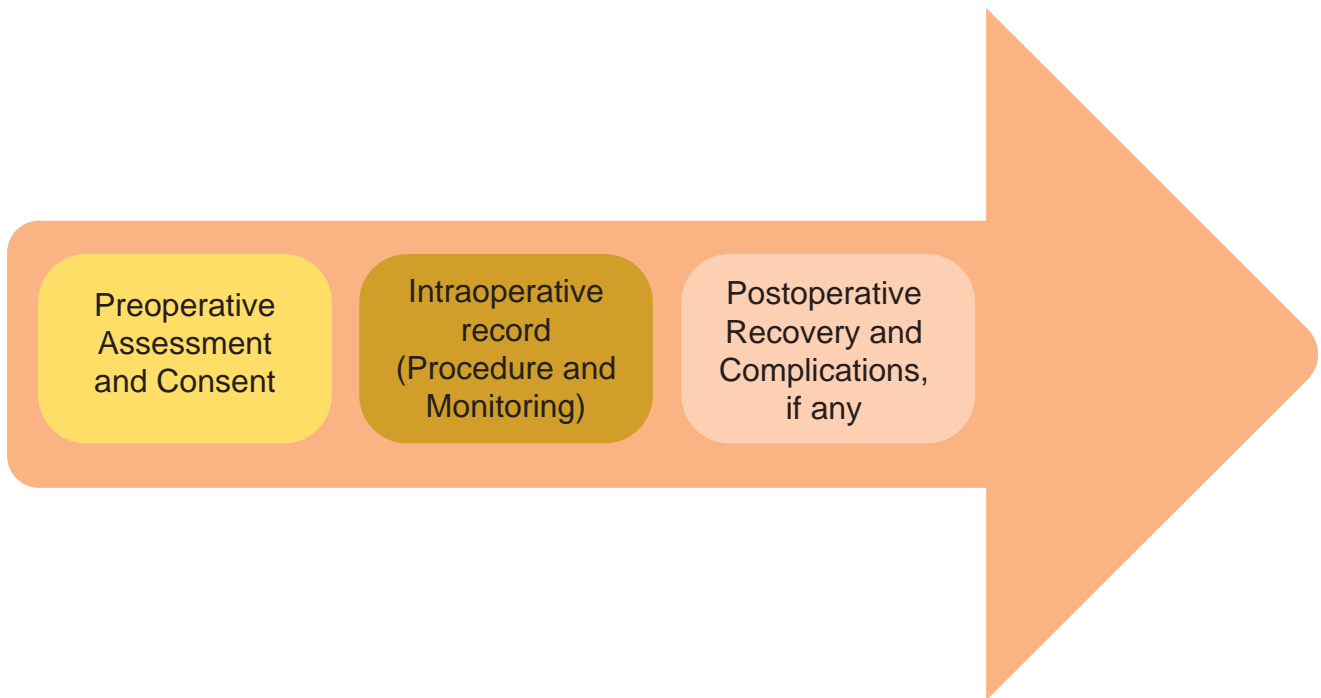
### IMPORTANCE OF RECORD KEEPING:

- To contribute to patient care.
- As an aid for audit of an anaesthetist's work.
- For teaching.

- Future research purposes
- For medico-legal reasons.

Patient care always takes precedence over record-keeping but events should be recorded as soon as possible after they happen.

## COMPONENTS OF RECORD KEEPING:



- Most of the Anaesthesia record documents can be written on case sheet or even better if a structured format is available to tick the boxes/fill in the information. A structure ready print paper helps save time, not allows to miss any point and is uniform in documentation across the areas and specialists.
- Remembering the various documents as per the timeline associated with surgery will be even more useful and easy i.e. Preoperative/intraoperative/postoperative
- Preoperative
  - Pre-Anaesthesia check-up (PAC) record sheet
  - Informed written consent
- Intraoperative
  - WHO surgical safety checklist (Starts just before the anaesthesia is induced in a patient with Anaesthesiologists, surgeon, and the nurse, all present and completing the checklist together)
  - Intraoperative Anaesthesia monitoring and record sheet
- Postoperative
  - Postoperative discharge scoring system

### Preoperative:

PAC - (A inclusive PAC check up preferably in a standard format): (Figure 1A and 1B)

Self-explanatory

- A completed PAC record is an important piece of document for the Anaesthesiologist as well as

for the surgeon.

- It needs to be meticulously filled up. It gives the Anaesthesiologist awareness about the patient's general condition, surgery planned at the exact site of the body and the exact procedure planned, what complications to anticipate and how best they can be optimized preoperatively – intraoperatively – postoperatively so that patient will have minimum morbidity while undergoing procedure.
- Even in an emergency, PAC needs to be assessed (Can be documented later as mentioned above) in a focused, brief, and rapid way. Its content should at least have the following
  - Demography, MRD number, Diagnosis and procedure planned, date
  - Medical history including exercise tolerance and past anaesthesia exposures and any complications encountered if ? Medication history is important.
  - Examination including airway and spine (specially for neuraxial anaesthesia planned procedure)
  - Appropriate investigations (biochemistry/pathology/microbiology/radiology).
  - Appropriate medical and surgical consultations, if any required for preoperative optimization.
  - ASA status documentation (including emergency, if any).
  - Anaesthesia planned.
  - Preoperative orders as appropriate

#### Informed written consent for both Anaesthesia and Surgery. ( Figure 2a and 2b)

- A separate chapter has been added in this module about medico legal aspects of anaesthesia
- It is important to emphasise here especially, in elective and even in emergency procedures (except for rare circumstances when it is not immediate life threatening condition which needs intervention without a delay), a written informed risk consent separate for anaesthesia is essential.

#### **Intra-operative:**

##### WHO Surgical safety checklist ( figure 3)

- WHO surgical safety checklist should always be filled.
- It has been designed for use across the globe by WHO for decreasing the errors and reducing adverse events associated in a perioperative event for a patient.
- There are total 19 items in the checklist
- They must be filled simultaneously by the Anaesthesiologist, Surgeon and the OT nurse.
- It has had positive effects shown in studies and can be one of the markers of patient safety and quality improvement.
- It is filled in 3 stages
  - Before Anaesthesia induction
  - Before the skin incision given by the surgeon
  - Before the patient leaves the operation theatre

### Intraoperative Record sheet (Figure 4a and 4b)

- Starts with a short PAC major highlights, preoperative Vitals
- Should be time-based record of events (Preferably in a standard format).
- Availability of necessary equipment for anaesthesia and resuscitation is documented
- Induction phase:
  - Documents what and how of “given Anaesthesia”, drugs with dosages and procedures done.
- Maintenance phase –
  - Continuous monitoring of physiologic data and recording it every 5 minutes
  - Type of Anaesthesia administered and drugs with dosages/IV fluids/Blood products used.
- Reversing of Muscle relaxant effects or any other drugs used during anaesthesia
  - Mention all the drugs with dosages used for this with dosages
- Complications, if any and their management.
- Patient status at shifting to PACU / Ward.

### Post-operative:

#### PACU discharge score sheet (Figure 5)

- Patients before shifting to Wards in postoperative period are generally held into post anaesthesia care unit (PACU) to observe complete recovery and watch for any immediate postoperative complications.
- The monitoring and vigilance is less frequent as compared to intraoperative monitoring but is more frequent as compared to wards.
- Standard PACU discharge scoresheets can be used to decide when a patient can be discharged back to ward
- Physiologic monitoring data.
- Complications if any.
- Any event / advise which needs to be followed up.

### KEY LEARNING POINTS

- Record keeping as in any branch of medical sciences is equally important in Anaesthesiology.
- Standard preprinted formats help in ease of maintaining records. A meticulous completed anaesthesia record helps in long way to help for improving the care, safety and quality management.
- Bare minimum essentials can be as follows (in a simple way)
  - Patient details.
  - Date of operation.
  - Name of the Anaesthesiologist and Surgeons.
  - Operation performed.
  - A summary of pre-operative assessment.
  - Techniques and drugs with dosages used.



- Intravenous fluids given during operation.
- Blood transfusion, including serial no. of the “blood group and unit”.
- Recording of Vital signs at 5 min. intervals.
- Complications, if any.
- Instruction to staff in the PACU.

## CHECK YOUR PROGRESS

Questions:

1. Enlist some of the common anaesthesia record keeping documents
2. Write a short note on PAC record sheet. Mention its components and importance.
3. What is a WHO surgical safety checklist? What are its components?
4. Write a short note on Intraoperative Anaesthesia record keeping.
5. The physiologic data monitoring in the intraoperative record system is documented every
  - a. 2 minutes
  - b. 5 minutes
  - c. 10 minutes
  - d. 15 minutes
  - e. Is not fixed, varies as per the patient’s condition
6. The WHO surgical safety checklist has components which are filled at different time lengths during an anaesthetic and surgery. They include all the following, except
  - a. Before the anaesthesia induction
  - b. Before surgical incision
  - c. Before patient is shifted from the operation theatre
  - d. Before patients is transferred from PACU to the wards

**Department of Anaesthesiology**  
**M.G.I.M.S. KASTURBA HOSPITAL, SEWAGRAM**  
**PRE-OPERATIVE ASSESSMENT RECORD**

Date .....

Name : ..... Age / Sex : ..... Wd/Bed/OPD : .....  
 MRD No : ..... CR No. : ..... Weight : .....  
 Diagnosis : .....  
 Surgery Planned : .....

**History of Presenting Complaints :**

H/o cough : ..... Dry / Productive / Mucoid / Blood Stained / Frank Blood H/o cold : .....  
 H/o dyspnoea : ..... At Rest / on Routine Exercise / on heavy exercise / PND. Palpitation : .....  
 H/o Hypertension : ..... Chest Pain : .....  
 H/o Diabetes : ..... Exercise Tolerance : (METS) .....  
 H/o Tuberculosis : ..... H/o Br. Asthma : ..... H/o Allergy (specify) : .....  
 H/o Previous hospitalisation / Surgery : .....

Addiction (if any) : smoking / alcohol / drugs / Others / Any other Significant History : .....

Current drug T/t With duration : .....

**GENERAL EXAMINATION :**

GC :	Built :	Height :	Temp :
Pulse :	B. P. :	Resp :	Pallor :
Icterus :	Oedema :	JVP :	Any other :

**AIRWAY ASSESSMENT :**

Dentition : Loose / Bucked / Protruding / Artificial / Edentulous / Missing + |  
 Mouth opening : ..... Neck Movement : ..... TMJ mobility : .....  
 M.P.C. grading : I / II / III / IV. IDL finding : ..... Any other : .....

**SYSTEMIC EXAMINATION :**

Respiratory system : A/E	P/A : Liver / spleen :	C.V.S. : HR ..... / min : Regular / Irregular.
Vesicular / Bronchial	* Ascites :	S1 / S2 : .....
Crackles / Rhonchi / Wheeze	* Tenderness :	Murmur : .....
Spine	* Rigidity / Guarding	C.N.S. : .....
Examination :	* Palpable mass :	Glasgow Coma Scale Score .....

**Investigations**

Hb% :	Platelets :	<b>Urine Examination :</b>	<b>Blood Sugar (mg%) :</b>
HcF :	PT/INR	Albumin :	Random :
TLC :	APTT :	Sugar :	Fasting :
DLC :	B. T. :	M/E :	P/P :
P. S. :			

Figure 1a : Pre – Anaesthesia checkup record sheet (sample format – front page)

Blood Group .....

Sickling / Electro-Phoresis.....

**RENAL FUNCTION TEST : LIVER FUNCTION TEST :**

Blood Urea : Sr. Proteins : Total : Ab : Glob :  
 Sr. Creatinine : Sr. Bilirubin : Total : Conj : Unconj :  
 Sr. Sodium : AST : ALT : ALK. Phosphatase : Sr. Amylase :  
 Sr. Potassium : Sr. CPK : Mb.

ECG :  
 X-Ray :  
 USG :  
 CT/MRI :  
 ECHO :

**Risk Assessment : ASA grade**  
 NYHA..... G.C.S. .... Any Other .....

**Lee's REVISED CARDIAC RISK INDEX**

	Points	Class
1. High Risk Surgery .....		
2. H/O IHD .....	0	I
3. H/O CCF .....	1	II
4. H/O CVA .....	2	III
5. DM on Insulin .....	3 or more	IV
6. Sr. Creat>2.0 .....		

Other Investigation : .....

Anaesthesia Notes	Anaesthesia Notes	Anaesthesia Notes

**FITNESS STATUS :** R<sub>x</sub>

Plan ..... NBM (hrs)..... XST .....

(Anaesthesiologist) Informed written Consent .....

Premedication .....

Figure 1b : Pre – Anaesthesia checkup record sheet (sample format )

**KASTURBA HEALTH SOCIETY**  
**Mahatma Gandhi Institute Of Medical Sciences & Kasturba Hospital**

**CONSENT FOR ANAESTHESIA/ANALGESIA/SEDATION/MAC**

I consent to the use of anaesthesia by my primary anaesthesiologist and his/her assistants. I understand that the use of anaesthetic or placement of intra-vascular lines for invasive monitoring may pose certain risks including, but not limited to temporary impairment of judgment, motor coordination and decrease in attention, nausea, vomiting, headache, sore throat, muscle aches, bruises, allergic reactions, tenderness or unintended pain in the site, I.V. infusions etc. despite taking all appropriate measures to prevent these. Furthermore, I have been specifically advised that there is a possibility of damage to my/the patient's teeth which are loose/weak/decayed/artificial during the procedure(S)-like intubation and administration of anaesthesia. I have been fully informed in the language that I understand, the nature and the purpose of anaesthesia, the possible risk and the possible alternative methods in view of associated medical/surgical conditions and I am satisfied with the information given. I am aware of the possibility of transfusion of blood or blood related products under the state of anaesthesia and fully understand its related complications. The content of the above paragraph I have been adequately explained and made understood to me in my language .....

**AUTHORIZATION OF PATIENT**

Hereby acknowledge that, I will not hold anaesthesiologist responsible for any of the above mentioned complication, which may occur unintentionally during the conduct of anaesthesia.

Patient Sign. _____	Date : _____
witness name / Sign. _____	Date : _____
Relationship _____	
Doctor name/sign _____	Date : _____

**Patient relative / representative**

The patient is unable to consent because :-

I therefore consent on behalf of the patient and hereby acknowledge that we will not hold anaesthesiologist responsible for any of the above mentioned complications which may occur during the procedure of anaesthesia.

Patient representative name/sign. _____	Date : _____
Relationship _____	
Witness name / Sign. _____	Date : _____
Doctor name/sign - _____	Date : _____

Figure 2a: A consent form for Anaesthesia



## महात्मा गांधी आर्युविज्ञान संस्थान व कस्तुरबा हॉस्पिटल

### सुंगनी व वेदनाहरन सासार्तीचे संमती पत्र

मी माझ्या रुग्णाच्या शस्त्रक्रिये दरम्यान भुलतज्ञ व त्यांच्या सहाय्यका द्वारा देण्यात येणाऱ्या सुंगनीसाठी संमती देत आहे. सुंगनी व सुंगनीशी संबंधीत कार्यपध्दती उदा. इंट्रुबेशन (घश्यात नळी घालणे), सेंट्रल लाईन, इंट्रा आर्टिरियल लाईन इत्यादी, दरम्यान शक्य सर्व दुष्परिणामांची पुर्व कल्पना मला भुलतज्ञांनी दिली आहे. सदर सुंगनीदरम्यान किंवा सुंगनीनंतर कार्यक्षमता व निर्णयक्षमता तात्पुरती कमी होणे, डोकेदुखी, अंगदुखी, मळमळणे, उलटी, एलर्जी, घसा खवखवणे, सलाईनसाठी वापरण्यात येणाऱ्या सुईच्या ठिकाणी सुज येणे / दुखणे, इत्यादी दुष्परिणाम उत्तम प्रकारची काळजी घेतल्यावरही होऊ शकतात याची पुर्णपणे कल्पना दिली आहे. या व्यतिरिक्त भुलतज्ञांनी मला स्पष्टपणे सांगितले आहे की, सुंगनी दरम्यान दातांना (खासकरून किडलेल्या/ढीले झालेल्या) इजा होऊ शकते किंवा पडू शकतात.

सदर शस्त्रक्रियेसाठी आवश्यक असलेल्या सुंगनीचा प्रकार आणि अशा प्रकारची सुंगनी देण्याची गरज याबद्दल पुर्णपणे कल्पना दिली आहे. माझी/माझ्या रुग्णाची सध्याची आरोग्याच्या स्थितीसाठी आवश्यक सुंगनीच्या प्रकारामध्ये असलेल्या धोका आणि या पध्दतीची पर्यायी पध्दत या बद्दल सांगण्यात आले आहे. सुंगनी दरम्यान मला/माझ्या रुग्णाला रक्त/रक्तघटक दिले जाण्याची शक्यता असून रक्त दिल्यानंतर होऊ शकत असलेल्या दुष्परिणामांची जाणीव मला आहे. वर देण्यात आलेली सर्व माहिती मला माझ्या ..... भाषेत भुलतज्ञांनी समजाऊन सांगितली आहे.

### रुग्णाची अधिकृतता

सदर सुंगनी दरम्यान होत असलेल्या कोणत्याही दुष्परिणामांसाठी (जे अजाणिपूर्व होऊ शकतात) भुलतज्ञांनी किंवा त्यांच्या सहाय्यकांज्या जबाबदार धरणार नाही.

रुग्णाची स्वाक्षरी	दिनांक
साक्षीदाराचे नाव / स्वाक्षरी	दिनांक
रुग्णाशी असलेले नाते	
डॉक्टरचे नाव / स्वाक्षरी	दिनांक

### रुग्णाची नातलग / प्रतिनिधी यांचे संमती पत्र

माझ्या रुग्ण शस्त्रक्रिये दरम्यान लागणाऱ्या सुंगनीसाठी संमती देण्यास अक्षम आहे कारण .....

..... याकारणास्तव रुग्णाच्या वतीने मी शस्त्रक्रिये साठी संमती देत आहे मी सुंगनी दरम्यान होणाऱ्या अजाणीवपूर्व दुष्परिणामांना भुलतज्ञ किंवा त्यांच्या सहाय्यकास जबाबदार धरणार नाही.

रुग्णाच्या नातेवाईक / प्रतिनिधी नाव व स्वाक्षरी	दिनांक
रुग्णाशी असलेले नाते	
साक्षीदाराचे नाव / स्वाक्षरी	
डॉक्टरचे नाव / स्वाक्षरी	दिनांक

Figure 2b: A consent form for anaesthesia in regional language

# Surgical Safety Checklist

## Before Induction of Anaesthesia

(with at least nurse and anaesthetist)

**Has the patient confirmed his/her identity, site, procedure, and consent?**

Yes

**Is the site marked?**

Yes

Not applicable

**Is the anaesthesia machine and medication check complete?**

Yes

**Is the pulse oximeter on the patient and functioning?**

Yes

**Does the patient have a:**

**- Known allergy?**

No

Yes

**- Difficult airway or aspiration risk?**

No

Yes, and equipment/assistance available

**- Risk of >500ml blood loss (7ml/kg in children)?**

No

Yes, and two IVs/central access and fluids planned

## Before Skin Incision

(with nurse, anaesthetist, and surgeon)

**Confirm all team members have introduced themselves by name and role.**

**Confirm the patient's name, procedure, and where the incision will be made.**

**Has antibiotic prophylaxis been given within the last 60 minutes?**

Yes

Not applicable

### Anticipated Critical Events

**To Surgeon:**

What are the critical or non-routine steps?

How long will the case take?

What is the anticipated blood loss?

**To Anaesthetist:**

Are there any patient-specific concerns?

**To Nursing Team:**

Has sterility (including indicator results) been confirmed?

Are there equipment issues or any concerns?

**Is essential imaging displayed?**

Yes

Not applicable

## Before Patient Leaves Operating Room

(with nurse, anaesthetist, and surgeon)

**Nurse Verbally Confirms:**

The name of the procedure

Completion of instrument, sponge, and needle counts

Specimen labelling (read specimen labels aloud, including patient name)

Whether there are any equipment problems to be addressed

**To Surgeon, Anaesthetist and Nurse:**

What are the key concerns for recovery and management of this patient?

The Checklist is not intended to be comprehensive. Addition and modification to fit local practice are encouraged.

Figure 3: WHO surgical safety checklist





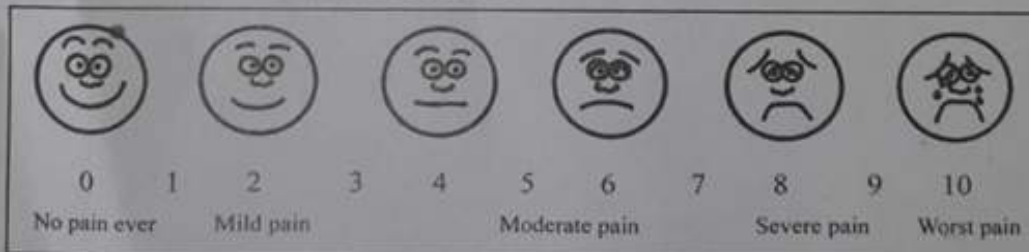


## OPERATION THEATRE - PACU AND RECOVERY ROOM DISCHARGE SHEET

PATIENT NAME : \_\_\_\_\_ CR : \_\_\_\_\_

Modified Aldrete Scoring System	
• Four extremities	2
• Two extremities	1
• No extremities	0
<b>Respiration</b>	
• Able to breath deeply and cough freely	2
• Dyspnoea, shallow or limited berathing	1
• Apnoea	0
<b>Circulation</b>	
• Blood pressure within 20 mm Hg of preoperative level	2
• Blood pressure within 20-50 mm Hg of preoperative level	1
• Blood pressure $\pm$ 50 mm Hg of preoperative level	0
<b>Consciousness</b>	
• Fully awake	2
• Arousable on calling	1
• Unresponsive	0
<b>Oxygen saturation</b>	
• Saturation > 92%	2
• Needs oxygen maintain saturation > 90%	1
• Saturation < 90% with oxygen	0

### POST OPERATIVE PAIN SCORE



- DISCHARGE FORM RECOVERY / PACU ORDERED BY (SIGN) : \_\_\_\_\_
- DESIGNATION : Nurse / J. Resident / SR / Consultant
- TIME:

Figure 5 : Post Anaesthesia care unit discharge score

# 26

## PACU Functioning

### INTRODUCTION:

- Recovery from Anaesthesia for most patients is smooth, uneventful from an uncomplicated anaesthesia & operation. But recovery can be life threatening at times in spite of best management by skilled physicians & nurses.
- Safe recovery from anaesthesia is key component of perioperative medicine.
- Ideally all patients who have received anaesthesia for any intervention which has been done should be monitored and managed in a post anaesthesia care unit or its equivalent till the patient satisfies the PACU discharge criterion and becomes ready to be shifted to the ward or home (when appropriate).
- The exception to the above can be a patient who had requirement of significant amount of vasopressors or someone who has been intubated and / or mechanically ventilated, who can bypass this and directly get admitted in an intensive care unit facility.
- As a rule, unless and otherwise stated, the PACU's policies about admission, management and discharge are managed by the Anaesthesiologists and his or her team. Therefore, it is imperative that an Anaesthesiologist is familiar with the functioning of PACU.
- The overall PACU functioning can be understood when looking at the following parameters
  - Functions.
  - Location & setup.
  - Resources: Manpower & Equipment.
  - Assessment, Monitoring & Care.
  - Discharge criteria from PACU.
  - Standards of care of PACU

### LEARNING OBJECTIVES:

After going through this module, you should be able to describe the:

Learning Objective	Knowledge	Skills
To understand the functioning of PACU in terms of location, manpower, equipment and its functioning.	✓	✓ Work in PACU unit to understand all these components

To understand the details of PACU discharge score	✓	✓ Fill up the PACU discharge scores form of the patient admitted to PACU and get these corrected by the Anaesthesiology supervisor
To understand the Standards applied for PACU functioning	✓	

### LOCATION:

- Close to OT.
- Early return to OT in case need arises. Close to surgeon & Anaesthetist.
- Near to ICU, Blood bank, X-ray, Small Lab.
- Approximately the Size should be roughly around 5 to 10% of total operations carried out per day which can be further modified depending upon resources, availability of other step down units. It might not be cost effective to run PACU for less than 4 beds.
- Isolation room for immunosuppressant / contaminated patients.

### SET-UP:

#### PACU general setup:

- Large door connected to OT for easy movement of ICU bed if required.
- Adequate light.
- Efficient environment control.
- Central nursing station.
- Storage & utility room.
- Proper waste disposal.

#### PACU Bed General Setup:

- Bed preferably with at least Trendelenburg position feasible. (if feasible, can have ICU types bed – Manual / remote with 4 or 6 functions)
- Bed with side railings desirable.
- Each bed with facility of Oxygen and Suction (Preferably central and Piped).
- Each Bed with Multi-parameter monitoring facility (ECG, NIBP, SpO<sub>2</sub>) desirable.

### Equipment:

- Multi-parameter monitor (ECG, NIBP, SpO<sub>2</sub>). Can have invasive monitoring multipara on some percentage of beds if resources are adequate and if high complex surgeries are performed daily in good numbers.
- Crash cart with essential emergency drugs & Defibrillator.
- Difficult airway cart.
- Documentation charts.

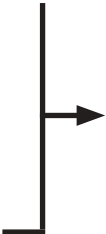
## FUNCTIONING CONCEPT OF PACU:

- Most patients after anaesthesia (GA / Neuraxial anaesthesia / Regional Anaesthesia / Monitored anaesthesia care) will receive care in PACU.
- Responsibility of Anaesthesiology personnel to take care in PACU.
  - Exceptions: Critically ill patients which can be directly shifted to ICU / Higher centers as appropriate.
- Traditionally the PACU care can be divided into
  - Transport phase to PACU
  - Phase I of recovery
  - Phase II of recovery
- **Transporting** a patient to PACU should ideally be done with Anaesthesiologist and Surgeon accompanying the patient with necessary monitoring equipment (at least pulse oximeter, ECG, NIBP) along with oxygen on a surgical stretcher with side railings.
- **Phase I of PACU** care generally implies that after coming out from anaesthesia in operating room suite to the time till when the Vitals are returning to near baseline as preoperative along with patient getting recovered from residual effects of anaesthesia.
- **Phase II of PACU** care many a times is not necessarily, performed in the dedicated PACU but can also be performed in the post-operative ward where less intense monitoring is required. This is more related to get the patient recover from post-surgery, getting him or her ready for discharge process.
- Appropriate handover to PACU nursing staff & / or Anaesthesia personnel in PACU, if different team. This should include:
  - Pertinent Medical history. (Significant PAC findings)
  - Surgical procedure performed.
  - Anaesthesia given.
  - Significant intraoperative events (Any complications during Anaesthesia and /or surgery)
  - Last drugs given & their timings. (especially sedatives, neuromuscular blockers, vasoactive medications)
  - Watch for complications, if anticipated.
  - Clear plan of monitoring and further management in PACU.
  - Plan of transfer to ward.

## INITIAL ASSESSMENT & MANAGEMENT:

- Again, it's easy to manage the patients just like "ABCD format" or paying attention to Ventilation, oxygenation, circulation, mentation and temperature in a post-operative – post anaesthesia patient along with other miscellaneous things as follows:
- Mental state and consciousness level.
- Airway patency.
  - RR.
  - Snoring, gurgling sounds
- Breathing:

- Continuous SPO<sub>2</sub>
- Cyanosis (Late sign)
- Circulation:
  - NIBP.
  - ECG (As applicable).
- Watch for complications (Separate lecture) – Anaesthesia related
  - System specific (Cardiovascular, Respiratory, Neurological)
  - Postoperative nausea vomiting
  - Pain
  - Hypothermia and shivering
  - Residual neuromuscular blockade
  - Recovery from spinal / epidural anaesthesia (especially if suspecting Spinal / epidural haematoma)
  - Difficulty voiding
- Watch for surgical complications
  - Bleeding
  - Irrigation fluids in certain surgeries



5 minutes for first 15 minutes & if stable then every 15-30 minutes till next two hours / adequate recovery

### SCORING SYSTEMS:

- Use of scoring systems in PACU creates a objective criterion, easy to use and perform. Criterion with safety for assessing readiness of shifting a patient
- A score of more than or equal to 9 indicates that patient is ready to be shifted out of PACU.
- It also helps identifying cases which are taking more than usual time to get ready to be shifted out of PACU thereby helping early to identify problems. Ideally, the form should be filled by Anaesthesiologist, however, in absence of Anaesthesiologist, can be filled up by PACU nurse after confirming the same with Anaesthesiologist at least through electronic means / telephonic communication.

Criteria	2	1	0
Activity	Moves all four extremities voluntarily or on command	Moves two extremities voluntarily or an command	None
Respiration	Breathes normally, coughs easily	Dyspnea, shallow or limited breathing	Apneic
Circulation	BP ± 20 mm of baseline	BP ± 20-50 mm of baseline	BP ± 50 mm of baseline
Consciousness	Fully awake	Arousable	Not responding
Oxygen saturation*	Maintain SaO <sub>2</sub> > 92% on room air	Maintain SaO <sub>2</sub> > 90% on supplemental oxygen	Unable to maintain SaO <sub>2</sub> > 90% even on supplemental oxygen
Color	Pink	Pale, "dusky," or "blotchy" discolouration, as well as jaundice	Cyanotic

Figure 2: Modified Aldrete score



## STANDARDS OF PACU FUNCTIONING:

- Ideally all patients who have undergone an Anaesthetic should receive care in PACU
- PACU policies and staffing should be mainly governed by the Anaesthesiologist
- When transporting the patients to PACU, ideally the patient should be monitored with multipara monitor, use along with clinical monitoring, oxygen available if needed and preferably done by Anaesthesiologist and Surgeon accompanying the patient
- PACU care will be done by PACU nurse under Anaesthesiology doctors supervision. A proper handover by Anaesthesiologist and operating surgeon to the PACU staff is very important (should be documented)
- Continuous monitoring will be carried out in the PACU which will be more intense than the Wards.
- For discharge of patient from PACU, objective criterion like scoring systems should preferably be used. They ideally should be assessed and documented by the Anaesthesiologist. However, in the absence the PACU nurse, can do this, inform the Anaesthesiologist who will assume the responsibility for shifting.

## TAKE HOME MESSAGE:

- PACU is integral part of managing a patient who has undergone anaesthesia and surgery.
- Vitals monitoring, anticipating complications and managing them early either by preventing them or if they occur treating them successfully is important function of PACU.
- Documentation of care in PACU is important aspect of PACU care.
- Standard scoring systems use is encouraged to discharge the patients from PACU.

## CHECK YOUR PROGRESS:

Q1. Write a short note on importance of PACU.

Q2. You are posted in FRU of a hospital as LSAS Anaesthesiologist. You have been given the task to set up a PACU. Describe how will you plan it ?

Q3. Describe any scoring system used in PACU.

Q4. Describe standards of PACU functioning.

## References:

- Fowler MA, Spiess BD. Postanaesthesia recovery. In: Clinical Anaesthesia, 7th ed, Barash PG, Cullen BF, Stoelting RK, et al (Eds), Lippincott Williams & Wilkins, Philadelphia 2013. Copyright © 2013 Lippincott Williams & Wilkins. [www.lww.com](http://www.lww.com).
- Chestnut Obstetric Anaesthesia.
- Standards for Postanaesthesia Care Committee of Origin: Standards and Practice Parameters. (Approved by the ASA House of Delegates on October 27, 2004, and last amended on October 23, 2019)



# 27, 28

## Complications in Perioperative setup I & II

### INTRODUCTION:

- Anaesthesiology is known for its commitment towards the patient safety and quality enhancement and has taken wide leap forward in this aspect by adopting evidence-based medicine along with introduction of checklists and protocols.
- For a safe perioperative outcome, it is important that Anaesthesiologist not only understands the technique of giving a safe anesthesia but also has a sound knowledge of managing perioperative complications which can be at times, life threatening.
- A basic approach to any complication is to anticipate the complication and to prevent it. If still it happens, one should have the ability to recognise it at the earliest stage and then manage them in a multi-disciplinary team approach wherever possible.
- This chapter will provide a basic idea about the same, but it's equally important that this is applied, and more is learned from observing day to day practice and evolve from it with experience.

### LEARNING OBJECTIVES:

After going through this module, one should be able to describe the:

Learning Objective	Knowledge	Skills
• Identify Life threatening complications.	✓	✓ • While attending the OT, identify the ways the anesthesiologists are using the skills and knowledge to prevent, recognise and manage the complications. • Implement them whenever appropriate under supervision . • Practice them and then demonstrate individually in Simulation lab - scenario based .
• ABC approach to emergency management of critically ill patient. • (Differentiate from the CAB approach used in cardiac arrest which will be dealt in next chapters)	✓	
• Individual systemic complications.	✓	

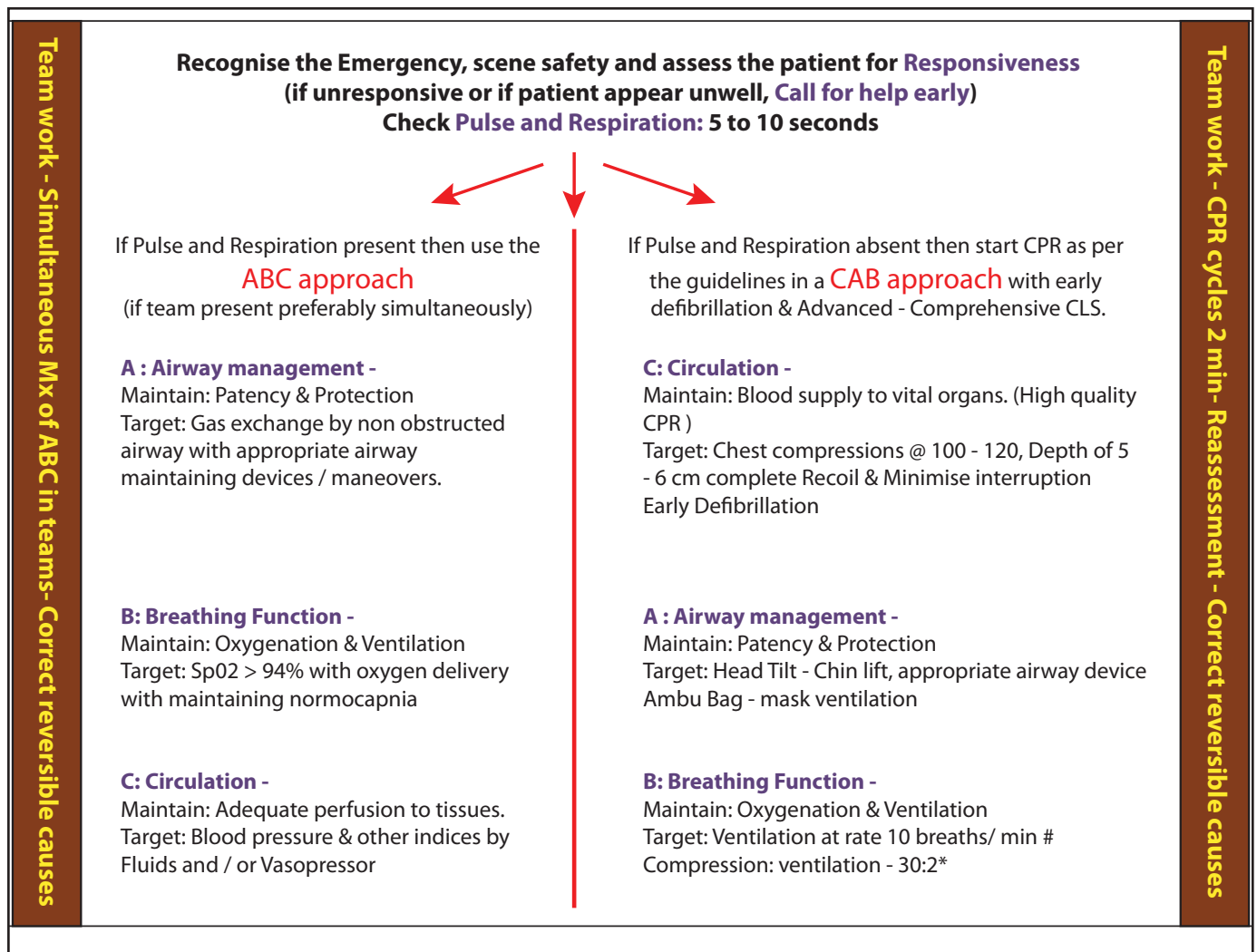
### Stepwise Approach to Management of Complications:

- The approach to all deteriorating or critically ill patients essentially in the initial period is more or less the same. Despite many different guidelines which are suggested, one of the commonly

approached ways can be summarized as follows and is shown in Figure 1.

- Use the Airway, Breathing, Circulation (ABC) approach to assess and treat the patient.
- Treatment of life-threatening problems always should get priority before moving to the next part of assessment.
- Assess the effects of treatment which has been administered.
- Recognize at the earliest when will you need extra help. Call for appropriate help early. It is critical to get “trained help” at the earliest possible.
- Team-work and principles of team-work & dynamics needs to be followed.
- Communicate effectively amongst team

Figure 1: ABC vs CAB approach



- The first aim of the initial treatment is to keep the patient alive and achieve some clinical improvement. This will get you extra time for further treatment and making a diagnosis.
- Once the initial life-threatening emergency is stabilized by ABC approach or if there is no life-threatening emergency, one can approach the complications by system specific or individual management of given complication.
- Practicing the management of life-threatening emergencies including event of cardiac arrest at regular interval by all the team members including paramedical personnel is essential to develop

a good team.

- A good team makes a big difference to better clinical outcomes in any given emergency patient.

### **Complications Occurring in the Post Anaesthesia Care Unit (PACU):**

(Anesthesia & Analgesia 1992; 74 (4):503.)

In one of the studies in PACU, the most common problems observed were:

- Post-operative nausea and vomiting: 9.8%.
- Upper airway complications: 6.9%.
- CVS system (e.g. Hypotension 2.7%, Arrhythmias 1.5%, Hypertension 1% and Major cardiac events 0.6%).

## **RESPIRATORY SYSTEM**

### **Changes in Respiratory System after GA:**

- Altered respiratory drive.
- Altered muscular function and respiratory mechanics.
- Reduction of lung volumes.
- Atelectasis being very common can develop in close to 3/4th of patients undergoing general anesthesia (especially with neuromuscular relaxant use).

*Postoperative pulmonary complications: A Miskovic et al. British Journal of Anaesthesia, 118 (3): 317-34 (2017).*

### **Respiratory Monitoring and Risk Assessment:**

- **Respiratory Monitoring:**
  - Airway patency and protection.
  - Respiratory rate and distress if obvious.
  - Peripheral oxygen saturation using pulse oximetry.
  - Vitals monitoring (Including HR, NIBP and Continuous ECG and SpO<sub>2</sub> Monitoring).
- **Risk Assessment:**
  - Patient related factors: e.g. Age, Comorbidities, Higher ASA classification.
  - Procedure related Factors: e.g. Surgery if close to diaphragm.
  - Anesthetic related factors: e.g. GA, GA with Neuromuscular blocking agents.

### **Preventive Measures:**

- Preoperative optimization of patient's comorbid conditions as much as feasible.
- Smoking cessation for as long as feasible.
- Correction of Anaemia (Transfusion trigger 7 - 8 Hb Gm% in most of the population).
- Lung protective ventilation.

- Appropriate & Judicious use of neuromuscular blocking agents.

### **Initial approach to Respiratory Insufficiency:**

Clinical features which herald more clinical attention and intervention in patients may include though not limited to:

- Tachypnea, RR > 30.
- Bradypnea, RR < 8.
- Obvious respiratory distress.
- SpO<sub>2</sub> < 93 - 94 on room air.
- Altered mentation.
- Tachycardia, Hypertension, Arrhythmias or Bradycardia.
- Necessary investigations along with ongoing treatment priority first.

### **Initial Management:**

- Oxygen administration: (Oxygen therapy chapter).
- Maintain upper airway patency and protection as appropriate
- Ventilator support.
- Secretion clearance.
- Appropriate treatment directed by symptomatology and diagnosis of specific condition.

### **Postoperative Pulmonary Complications (PPC):**

- Many ways to classify PPC in use.
- One of the simple ways to define PPC: Any event which requires either requirement of pharmacological agents or non-pharmacological agents (including oxygen, Ventilator support, other agents) to support RS meet its targets in the terms of oxygenation and ventilation.
- Traditionally they have been classified to include Exacerbation of COPD, Pneumonia, Atelectasis, and bronchospasm. These can be further extended to include Pleural pathologies, Pulmonary oedema, ARDS, Pulmonary embolism and death due to RS complications.

### **PPC Classification:**

- **Upper Airway Complications:**
  - Laryngospasm.
  - Airway edema.
  - Obstruction of sleep apnoea.
  -
- **Lower Airway and Pulmonary Complications:**
  - Bronchospasm.
  - Pneumonia.
  - Pulmonary edema.

- ARDS.
- Atelectasis.
- Pleural pathology: Effusion or Pneumothorax.
- Complications because of Neuro-muscular system:
  - Opioids and Anaesthesia agents.
  - Neuromuscular agents.

### Definitions of common Pulmonary Complication:

Outcome Measure	EPCO Definitions (Identical Set Used by Canet and Colleagues and Subsequent Studies)	Other Published Definitions
Respiratory Infection	Antibiotics for suspected infection with one or more of the following: new or changed sputum, new or changed lung opacities, fever, white blood cell count $>12 \times 10^9 \text{ L}^{-1}$	Two or more of the following for >48 hours: new cough/sputum production, physical findings compatible with pneumonia, fever $>38^\circ\text{C}$ , and new infiltrate on CXR
Respiratory Failure	Postoperative $\text{PaO}_2 <8 \text{ kPa}$ (60 mm Hg) on room air, a $\text{PaO}_2$ ratio $<40 \text{ kPa}$ (300 mm Hg), or arterial oxyhaemoglobin saturation measured with pulse oximetry $<90\%$ and requiring oxygen therapy	Ventilator dependence for $>1$ postoperative day or re-intubation; Need for postoperative mechanical ventilation $>48 \text{ h}$ ; Unplanned re-intubation because of respiratory distress, hypoxia, hypercarbia, or respiratory acidosis within 30 days of surgery; Re-intubation within 3 days requiring mechanical ventilation; Postoperative acute lung injury; ARDS; Requiring mechanical ventilation within 7 days of surgery; Requiring NIV
Atelectasis	Lung opacification with mediastinal shift, hilum, or hemidiaphragm shift towards the affected area, with compensatory hyperinflation in adjacent non-atelectatic lung	Requiring bronchoscopic intervention; Major atelectasis (one or more pulmonary segments)
Bronchospasm	Newly detected expiratory wheeze treated with bronchodilators	Clinical diagnosis resulting in change in therapy; Refractory wheeze requiring parenteral drugs in addition to preoperative regimen
Aspiration Pneumonitis	Acute lung injury after inhalation of regurgitated gastric contents	Radiographic change and antibiotics

Pneumonia	CXR with at least one of the following: infiltrate, consolidation, cavitation; plus at least one of the following: fever >38°C with no other cause, white cell count <4 or >12 × 10 <sup>9</sup> L <sup>-1</sup> , >70 years of age, with altered mental status with no other cause; plus at least two of the following: new purulent/changed sputum, increased secretions/suctioning, new/worse cough/dyspnoea/tachypnoea, rales/bronchial breath sounds, worsening gas exchange	Antibiotics with new/changed sputum or radiographic change or fever or increased white cell count >12,000 µL <sup>-1</sup> ; Two or more of the following for ≥2 consecutive days: new cough/sputum production, examination compatible with pneumonia, temperature >38°C, and radiographic change; New or progressive infiltrate on CXR or crackles or dullness on percussion and any of the following: new purulent/changed sputum, positive blood cultures, isolation of pathogen from sputum; Positive sputum culture or infiltrate on CXR, and diagnosis of pneumonia or pneumonitis; New infiltrate on CXR plus fever, leucocytosis, and positive sputum Gram stain/culture; Ventilated, bilateral infiltrates on CXR
ARDS	Not mentioned in this section	Not mentioned in this section

From BJA: Volume 118, Issue 3, March 2017, Pages 317–334

## FEW SPECIFIC COMPLICATIONS OF RS AND THEIR MANAGEMENT:

### Pulmonary Aspiration of Gastric Contents:

- May occur before, during or after operation.
- Major cause of death.
- Describe by Mendelson in 1946.
- Due to damage to respiratory epithelium or vascular endothelium leads to leakage of fluid into alveoli & interstitial spaces.
- **Hydrodynamics:**
  - Normal intragastric pressure is 5 to 7 cm. of water.
  - If it is >18 cm, decrease tone of Lower esophageal Sphincter (LOS): Regurgitation.
  - Under anesthesia tone of Cricopharyngeal sphincter decrease: Aspiration.
- **Predisposing Factors:**
  - Full stomach.
  - Decrease level of consciousness.
  - Conditions: Decrease tone of LOS.
    - Pregnancy, Abdominal tumors, Obesity, Hiatus hernia, Presence of Ryles Tube, Drugs.
  - Conditions: Delay gastric emptying
    - Pain, Anxiety, Diabetes, Hypothyroidism, Electrolyte imbalance.
- **Risk Factors:**

- Volume : 25 ml.
- PH : 2.5.
- Solid Particle.
- **S / S:**
  - Gastric contents into oropharynx.
  - Tachypnea, Tachycardia.
  - Cough (Laryngospasm, Bronchospasm).
  - Wheezing & Crepitation.
  - Cyanosis.
  - Decrease O<sub>2</sub> saturation.
  - Shock.
  - Findings in X-ray chest.
  - Phase 1:
    - Profound Dyspnea, Tachypnea, Bronchospasm, X- ray chest- Normal.
  - Phase 2:
    - Cyanosis, Decrease O<sub>2</sub> Saturation, Minor X-ray chest abnormalities.
  - Phase 3:
    - Respiratory Failure, Profound decrease O<sub>2</sub> Saturation, X-ray chest: Diffuse Bilateral Infiltrate.
  - Phase 4:
    - Metabolic & Respiratory Acidosis, no response to O<sub>2</sub> Therapy.
- **Prevention:**
  - Nil By Mouth.
  - Antacids: H<sub>2</sub> blockers and Metoclopramide.
  - Head up position.
  - Rapid sequence induction.
  - Cricoid pressure / E.T. intubation.
  - Awake extubation.
  - Recovery room: Well equipped & staffed.
- **Treatment:**
  - Turn patient on one side and Head down position.
  - Suction.
  - Oxygen.
  - Bronchodilators, Antibiotics, Steroids.
  - Physiotherapy.
  - IPPV may be required.
  - Tracheal lavage ?.



## \* Hypoxia:

### • Causes:

1. Inadequate O<sub>2</sub> supply.
2. Respiratory obstruction.
3. Hypoventilation.
4. Ventilation perfusion abnormalities.
5. Cardiac causes.
6. Others rare like Cyanide toxicity, Hypothermia, Alkalosis etc.

### 1. Inadequate O<sub>2</sub> Supply:

- Exhausted store.
- Leak in machine & circuit.
- Disconnection or malposition of the tube.

### 2. Respiratory Obstruction:

- Signs:
  - Inadequate Tidal Volume.
  - Retraction of chest wall.
  - Use of accessory muscles of respiration.
  - Noisy breathing.
- Causes:
  - a. Obstruction at the Lips: In Edentulous Patients.  
Treatment: Oro / Nasopharyngeal airway
  - b. Obstruction by Tongue: Abolition of tone of Genioglossus Muscle.  
Treatment: Jaw Lift and Extension of head, Oro / Nasopharyngeal airway and Intubation.
  - c. Obstruction above the glottis: Due to Foreign body, Secretion or Oedema, Treat the cause.
  - d. Obstruction at the glottis: Foreign body, Laryngeal Spasm (Peripheral Stimulation).  
Treatment: Remove the Foreign body or Secretions, Oxygen, IPPV, Succinylcholine.
  - e. Bronchospasm: A tendency to Asthma predisposes bronchospasm., Inadequate depth of Anaesthesia or Acute infection. Irritability at Carina increases sensitivity, Acute anaphylactic reaction.  
Treatment: Smooth induction & Maintenance, Bronchodilators, Corticosteroids, Adrenaline.
  - f. Kinking or blockage of ET by Secretions: Treat the cause.

### 3. Hypoventilation:

- Overdose of anaesthetic agents.
- CNS disorders.
- Inadequate reversal.

- Pain.
- Leaks in machine / circuits.

#### 4. Ventilation Perfusion Abnormalities:

- Atelectasis.
- Surgical emphysema.
- Pneumothorax.
- Pulmonary embolism.
- Pulmonary oedema.
- Lung abscess.

#### \* **Atelectasis:**

- Most common cause of post op hypoxia: Due to secretions.
- Poor expulsion due to:
  - Decrease movement of diaphragm.
  - Pain.
  - Residual myoneural block.
  - Sedatives.
  - Tight binder / Dressing.
  - Prolonged inhalation of cold, Dry gases: Decrease ciliary activity.
- Treatment:
  - Of the cause.
  - Physiotherapy, Suctioning of secretions.
  - Analgesics.

#### \* **Surgical Emphysema:**

- May commence as a pulmonary interstitial emphysema due to over distension of the alveoli.
- The gas tracks & spread to Neck, Abdomen, , in to the pleura (Tension Pneumothorax).
- Treat the cause.

#### \* **Pneumothorax:**

- Accidental opening of pleural cavity during operation such as:
  - Cervical Sympathectomy.
  - Rib Resection.
  - Nephrectomy.
  - Anaesthesia Technique:
- Intercostal / Brachial block.
- IPPV Specially using. PEEP.
  - Laparoscopy.

- Treatment: Inter Costal Drainage.

### \* **Pulmonary Embolism:**

- Common postoperatively.
- Common in:
  - Immobilized Patients, Elderly Patients.
  - Patients having DVT in Legs.
  - Patients on Oral Contraceptive.
  - After Pelvic surgery, Hip surgery.
  - Liquor amni in Obstetric Patient.
- Signs & Symptoms:
  - Sudden onset of chest pain.
  - Dyspnoea, Hemoptysis.
  - Tachycardia, Hypotension.
  - Increase CVP.
  - If massive shock & cardiac arrest.
- Treatment:
  - Prevention of DVT.
  - Early Ambulation, Leg Movement in Bed.
  - Pneumatic compression of calf muscles.
  - Anticoagulants.
  - Thrombolytic (Specialist opinion: Shock with PE)

### \* **Pulmonary oedema:**

- An increase in fluid content of the extravascular tissues of the lung.
- Causes:
  - Cardiogenic, Non-cardiogenic.
  - Fluid overload, Trauma, DIC.
  - Aspiration of gastric contents, Emboli.
  - Multiple transfusion etc.
- During Anaesthesia:
  - Secretions in ET tube (Pink, Frothy).
  - Hypoxia, Cyanosis.
  - Variable B.P.
- Treatment:
  - 100% O<sub>2</sub> with Non-invasive Ventilation / IPPV (PEEP).
  - Furosemide : 1mg / Kg bolus IV (Watch for BP).
  - Morphine: Venodilatation & Decrease Preload (Watch for Respiratory depression).

- Vasopressors as per need.
- If B.P. is maintained, NTG drip.
- Weaning from ventilation.

#### \* **Cough:**

- Common intraoperative, Due to inadequate depth of Anaesthesia, when patient has inflammation of Upper airway.
- Irritation of larynx from regurgitated material, Use of airway, Secretions etc.
- **Treatment:** Deepening of Anaesthesia.

#### \* **Hiccup:**

- Intermittent spasm of Diaphragm due to sudden closure of glottis.
- **Cause:**
  - Peripheral: Stimulation of Sensory nerve endings of Phrenic nerve.
  - Central: Stimulation of Medulla.
- **Treatment:**
  - Deepening of Anaesthesia.
  - Addition of muscle relaxant if patient already under GA and Neuromuscular blockage.
  - Nasopharyngeal Stimulation.

## **CARDIOVASCULAR SYSTEM**

- Peri-operative Hemodynamic problems can be oriented as per the cause specific or symptom specific which includes Hyper / Hypotension, Tachy / Brady arrhythmias – ultimately leading to either decreased cardiac output and /or decreased tissue perfusion leading towards a path of anaerobic metabolism.
- **These problems can be either a cause of or can lead to:**
  - Heart failure (Decompensated).
  - Ischemia to Myocardium and its Sequelae.
  - Valvular or structural heart diseases
  - Peri-partum cardiomyopathy

### **Risk Factors:**

- **Preoperative Factors:**
  - Preexisting CVS comorbidity.
  - Obstetric related cardiac comorbidities (e.g. hypertensive disorder of pregnancy)
- **Intraoperative Factors:**
  - Nature of surgery (Invasiveness).
  - Effects of Anesthesia agents and techniques.
- **Postoperative Factors:**

- Hypotension.
- Tachycardia.
- Inadequate pain relief, Sympathetic surges.

## Hypotension:

### Causes:

- Can present in Perioperative Settings:
- Hypovolemic / Haemorrhagic shock.
- Cardiogenic shock.
- Septic shock.
- Anaphylactic shock.
- Local Anesthesia systemic toxicity.
- Tension Pneumothorax (Rare but life threatening).
- Pulmonary embolism.
- Vasodilatation because of Anaesthesia agents (e.g. Neuraxial anaesthesia, Volatile agent).

### Initial Assessment & Treatment:

- Determining Hypotension (Absolute values vs Relative fall from baseline readings).
- Clinical signs and symptoms of inadequate perfusion.
  - Vitals
  - Skin changes
  - Central nervous system – altered mentation
  - Urine output
  - Other organ sign or symptoms suggesting decreased perfusion
- Ongoing treatment along with necessary investigations.

### Initial treatment:

- Warm IV crystalloids (NS / RL) 250 – 500 ml boluses if no relative contraindications like decompensated heart failure, Acute pulmonary oedema, Chronic renal failure with fluid overload states.
- Use of Vasoactive medications (Vasopressors / inotropes/ inodilators)
- Urgent stabilization and referral to a nearest tertiary care center whenever earliest window of opportunity arises while stabilizing the patient.

## Hypertension:

### Causes:

Intraoperative	Postoperative
Light Anaesthesia	Pain
Laryngoscopy & Intubation	Full Bladder
Hypercapnia	Hypercapnia

Intraoperative	Postoperative
Drugs	Drugs
Disease	Disease

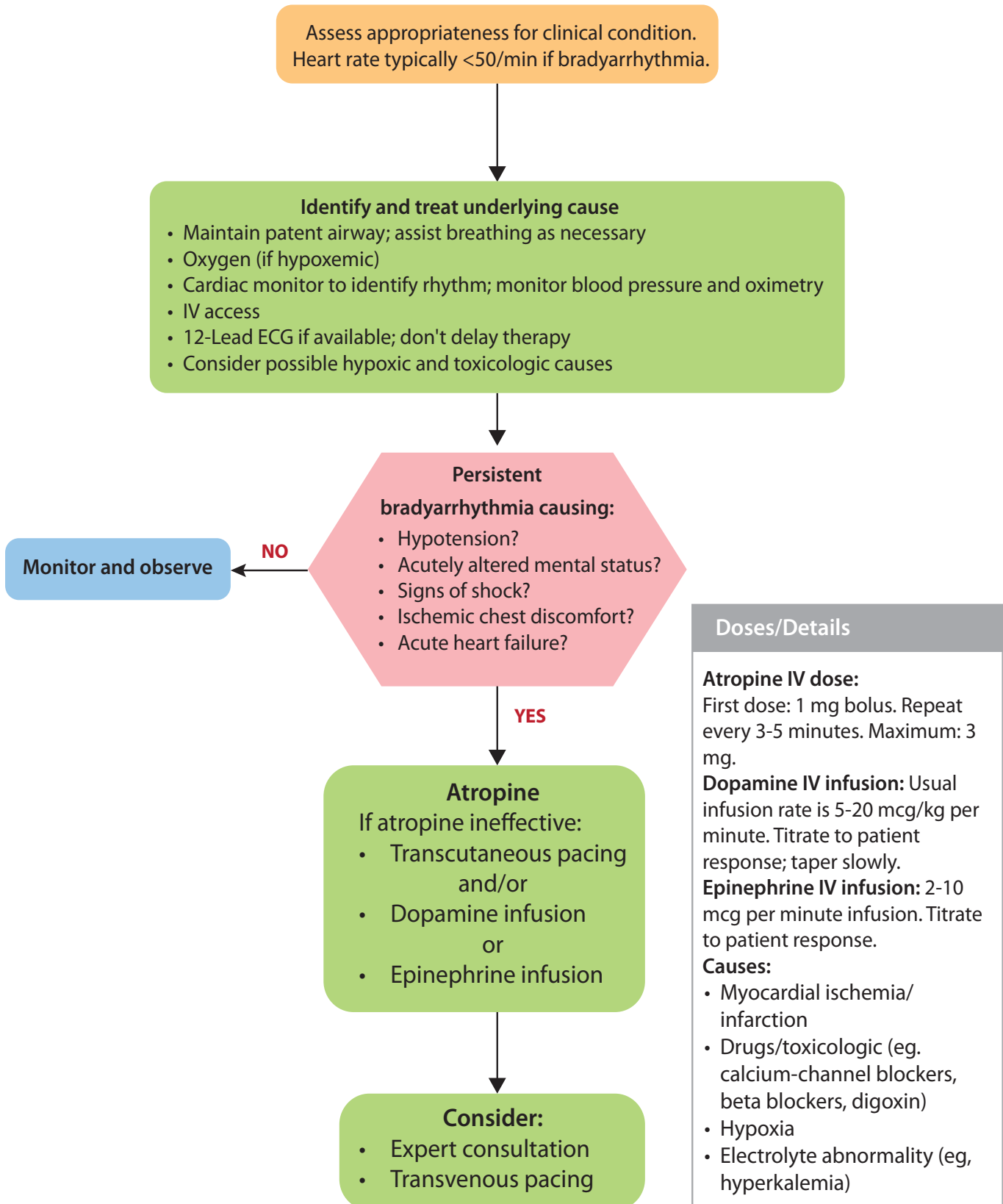
### Initial Assessment & Treatment:

- Determining Hypertension (Determining threshold for treatment is equally important: e.g. Postoperative hypertension should be treated if SBP > 180 / diastolic > 100 mmHG).
- Clinical signs and symptoms of hypertensive emergency / urgency.
  - CNS – Focal deficits suggestive of bleed / decreased perfusion
  - CVS – Hypertensive LV failure, chest pain
  - Other organs sign symptoms
- Ongoing treatment along with necessary investigations.
- Treat underlying cause precipitating hypertension (e.g. Noxious stimuli).
- Pharmacological agents
  - Vasodilators, Antihypertensive appropriate for the given situation considering all indications and contraindications (beta blockers, nitrates, vasodilators)
  - E.g. Labetalol, Hydralazine, Nitroglycerine – Acute purposes IV use
  - ACE inhibitors, calcium channel blockers (Amlodipine) – if oral & not acute conditions

### Cardiac Arrhythmias:

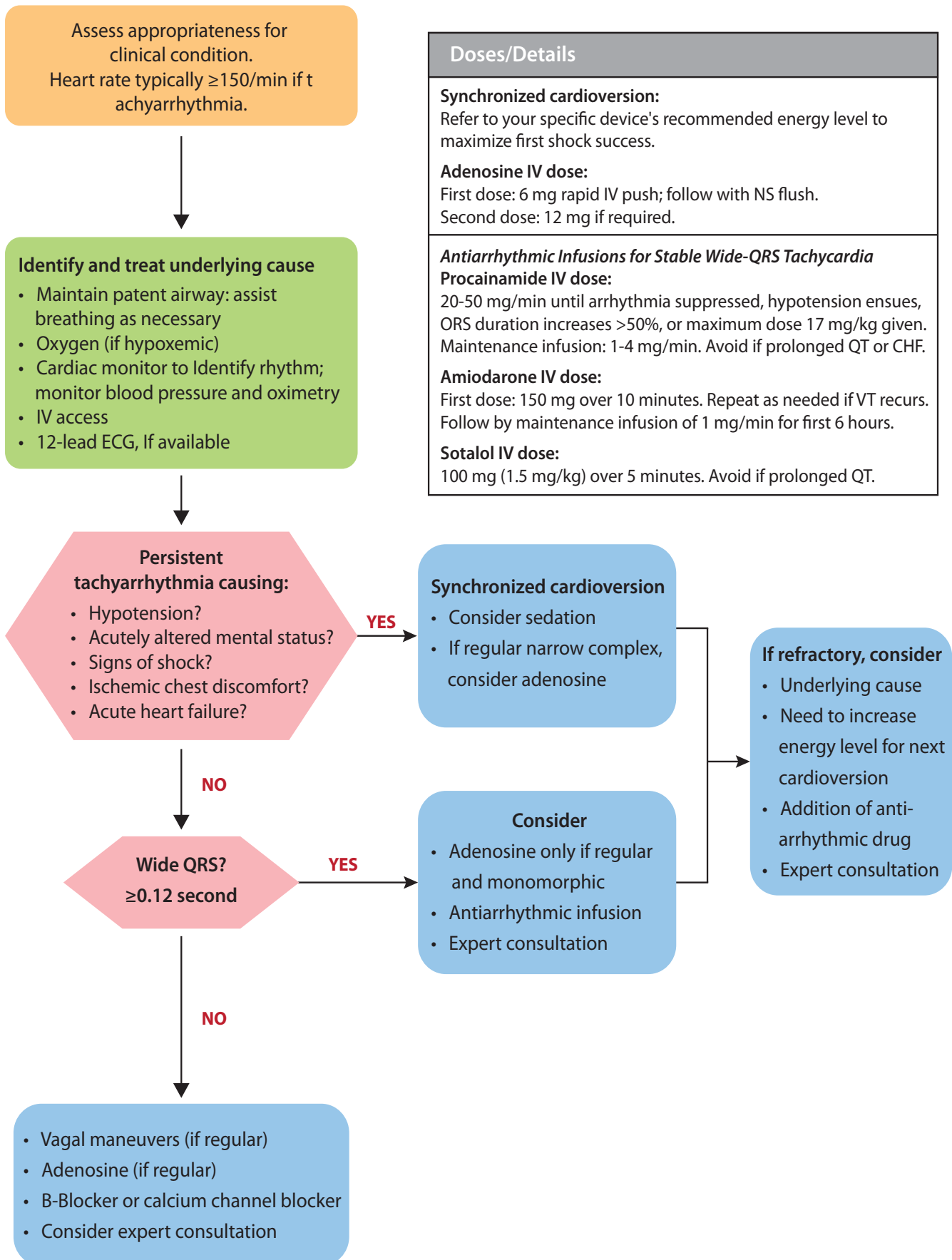
- Association with:
  - Preexisting cardiac pathology.
  - Hypercarbia, Hypoxia.
  - Toxemia, Drugs.
  - Electrolyte imbalance.
  - Myocardial ischemia / Infarction.
- Range from:
  - Bradycardia to Arrest.
  - Tachycardia to Ventricular Fibrillation.
- Treatment:
  - One of the basic principles to manage any arrhythmia is to define if it's causing acute unstable condition in the body by decreasing the cardiac output thereby causing decreased perfusion. If such a condition occurs, the arrhythmia needs urgent management, while if the arrhythmia if present is not causing above --- one might have the opportunity to take a appropriate expert consult.
  - It is important to remember that above situation is not static but is dynamic and any so called "stable arrhythmia", which might deteriorate into unstable arrhythmia and any unstable arrhythmia might culminate into cardiac arrest. Therefore, eternal vigilance. Basic idea about managing them as syndrome of tachyarrhythmia or Brady arrhythmia at least in the initial part of the disease should be well known to every treating Anaesthesiologist.
  - Please find below the AHA guidelines algorithm for treating the arrhythmias.

## Adult Tachycardia With a Pulse Algorithm





## Adult Tachycardia With a Pulse Algorithm



## NEUROPSYCHIATRIC COMPLICATIONS

### Awareness:

- Conscious explicit recall of events under anaesthesia (General Anesthesia) while undergoing surgery. Though not very common in obstetrics because of more common use of regional (neuraxial anesthesia) it is still important to understand to prevent distress to patient as well as from the medico legal point of view.
- Most common is auditory.
- Types:
  - Conscious awareness without amnesia.
  - Conscious awareness with amnesia.
  - Subconscious awareness.
  - Pseudo awareness.
- Premedication with benzodiazepines (Produce anti-grade amnesia and inhalational agents).

### Delayed Recovery: (under General Anesthesia)

- Inadequate reversal.
- Over dosage of opioid or inhalational agents.
- Electrolyte imbalance.
- Acid-base abnormalities.
- Metabolic abnormalities like Hypoglycemia.
- Endocrine disorders like Hypothyroidism.
- Liver / Renal dysfunction.
- Shock.
- CVA.
- Air embolism, Fat embolism.
- Operative trauma in brain surgery.
- Hypothermia.
- More often than not these conditions are generally temporary occurrence, eventually most of them will awaken.
- Most of them would resolve over a period of half an hour to over 1 hour.
- Remember, in rare cases and especially when not resolving, one should suspect for serious neurological or medical pathology which needs immediate assessment, investigation and further treatment including appropriate consultation.

### Convulsions:

- Hypoxia.
- Drugs like local Analgesics, Methohexitone, Enflurane etc.
- Cerebrovascular accidents.
- Epilepsy / Eclampsia
- Treatment:

- ABC first including checking of blood glucose
- Benzodiazepines, Definitive anticonvulsants.
- Treatment of underlying cause and prevention of next convulsion episode.

### Extrapyramidal Side Effects:

- Causes:
  - Phenothiazines, Butyrophenone derivatives.
  - Metoclopramide, Levodopa.
- Signs & Symptoms:
  - Acute Dystonia.
  - Painless Spasmodic Contractions, Dyskinesia.
- Treatment:
  - Withdraw drugs.
  - Diazepam.

### Agitation & Delirium:

- Due to:
  - Pain, Drugs, Full Bladder.
  - Underlying condition
  - Prolonged ICU stay
  - Peri-partum psychosis
- Treatment:
  - Prevention of Delirium should be achieved whenever feasible (e.g. in ICU – frequent orientation to patient for date and time, trying to maintain the circadian rhythm – lighting adjustments according to day of time, promoting sleep appropriately, keeping the noise in ICU to minimum especially in the night)
  - Treatment of underlying causes
  - Antipsychotics (e.g. Haloperidol / Quetiapine), Benzodiazepines ( at times increases delirium if used excessively), newer alpha 2 agonists like Dexmedetomidine for short duration ( Looking at the indications, side effects and contraindications )
  - Always important at least in the ICU setup to treat Analgesia first followed by sedation
  - Take expert help at the earliest

### Peripheral Neuropathies:

- Causes:
  - Stretching & Compression of Nerves (Malposition).
  - Direct injection of drug in Nerves during block.
  - Use of Tourniquets.
  - Prolonged Hypotension (Nerve Ischemia).

- **Ulnar Nerve:**
  - Against medial epicondyle of Humerus.
- **Brachial Plexus:**
  - Extension & Lateral Flexion of head to opposite side.
  - Extreme Abduction of arm above head.
- **Lateral Popliteal N.:**
  - Between head of Fibula & Lithotomy Pole.
- **Saphenous N.:**
  - Between Lithotomy pole & Medial Tibial Epi.
- **Sciatic Nerve:**
  - During I.M. Injection.
- **Femoral Nerve:**
  - From retractor during Lower Abdominal Laparotomy.
- **Supraorbital N.:**
  - Compression by metal connector or tight head harness.
- **Facial Nerve:**
  - Between Fingers & Ramus of mandible.

### Treatment

- Important to prevent the nerve compression related neuropathies
- Anaesthesiologist are equally responsible for "Surgical position" related neuropathies
- Always pad the pressure areas especially for superficial nerve related pathies (e.g. to prevent foot drop in lithotomy position), do not overextend the range of normal degree of limb movements especially under anesthesia causing the nerves to stretch
- Keep a vigilance in postoperative period to identify early sign and symptoms of neuropathy and referral to tertiary care center for expert help at the earliest

### Spinal Epidural Haematoma:

- Rare complication of Neuraxial Anaesthesia.
- Patients who receive spinal or epidural anesthesia with Bleeding disorders / Coagulopathy / medications affecting Haemostasis are at increased risk.
- **Assessment:**
  - High degree of suspicion in background of relevant clinical history and exposure: Cause.
  - Symptoms may not become obvious till effect of anaesthesia have been worn off.
  - In suspected cases or even otherwise, examining for motor and sensory block regression and documentation of same is important.
  - Progressive motor / Sensory block.

- Bowel / Bladder dysfunction.
- Less commonly back pain.
- **Investigate & Manage:**
  - Emergent MRI / CT scan.
  - Urgent consultation with Neurology / Neurosurgery to evacuate haematoma within 6 - 12 hours before more permanent neurological injury sets in.
  - Prevention is best way to manage. Though rare complication, if not prevented or recognized early, it has potential to become a major cause for morbidity.
  - One of the simple way to manage this is to have a habit to follow up the patient who has received spinal or epidural anaesthesia and watch for sensory and motor recovery from the neuraxial anaesthesia in postoperative period (preferably within 6 hours).
  -
- **Other Complications:**
  - PONV.
  - Hypo / Hyperthermia.
  - Position related injuries.
- **Post-Operative Nausea Vomiting (PONV):**
  - Patients often rate PONV worse than post-operative pain.
  - **Risk Factors:**
    - Patient related:
      - Female gender, H/o PONV, Motion sickness, Age < 50.
    - Anaesthesia related factors:
      - Use of GA.
      - Inhalational > Propofol based Anaesthesia.
      - Postoperative opioid administration.
  - **Treatment:**
    - Phenothiazines:
      - Stemetil (Prochlorperazine).
      - Phenargan (Promethazine).
    - Metoclopramide, Domperidone.
    - Ondansetron (5 HT3 receptor antagonist).
    - Single dose Dexamethasone IV (Risk of Hyperglycemia).
- **Hypothermia:**
  - 10 - 45 % post op period.
  - Important factor contributing to increased surgical site infections.
  - Affects various systems of body lead to Dysrhythmia, Decrease Cardiac output, Vasoconstriction,

Depressed respiration, Acidosis, Decrease CBF & ICP, decrease metabolism, Hyperkalemia, Duration of block increases etc.

- Shivering which occurs because of the hypothermia increases oxygen consumption.
- **Management:**
  - Prevention is the best treatment (Warm IV fluids, warming devices, adequate body cover in OT whose ambient temperature is low, maintaining OT temperatures at the specified range rather than decreasing it too much are few of the easy interventions which can be done)
  - Active rewarming.
  - Supportive treatment to affected system.
- **Shivering:**
  - Shivering may occur with Hypothermic patients as well as with febrile patients.
  - Results in excessive sympathetic stimulation.
  - Increase in the oxygen consumption overall causing sympathetic surge, lactic acidosis. In patient with limited cardio-respiratory reserve, at times this excess demand of oxygen caused by shivering may lead to myocardial ischemia rarely.
  - Significant discomforting problem to patient as well as relatives.
  - One of the common complaints in the post-operative care units.
- **Treatment:**
  - As mentioned above Adequate environmental control.
  - Pethidine / Dexmedetomidine / Tramadol are used with varying success.
- **Fever or Hyperthermia:**
  - Core body temperature > 102 degree Fahrenheit.
  - Typically treated with Acetaminophen.
  - Intraoperative fever (Rarely postoperative persistent or occurrence) can be because of life threatening conditions like Malignant hyperthermia, Neuroleptic malignant syndrome, thyroid storm.
    - Life threatening: Hyperthermia:
  - Heat production exceeds the heat loss.
- **Causes:**
  - Malignant Hyperthermia.
  - Hypermetabolic State (Thyrotoxicosis).
  - Anticholinergic.
  - Injury to Hypothalamic temperature regulatory centers.
- **Malignant Hyperthermia:**
  - Inherited autosomal dominant disease, abnormality in Ca releasing channel of sarcoplasmic reticulum.
  - Signs & Symptoms:
    - Cyanosis, Muscle Rigidity, Hypercapnia, Dysrhythmia, Pyrexia.
    - Masseter spasm is one of the earliest sign, which can be noted in patients under general anesthesia

- Capnography will show a rapidly rising EtCO<sub>2</sub> which constantly keeps getting raised in inspiratory CO<sub>2</sub> levels also (because of rapid production, overwhelming the capacity to absorb the CO<sub>2</sub> in CO<sub>2</sub> absorbed material used in the closed circuit)
- Causative Agents:
  - Muscle relaxant: Succinyl choline.
  - Inhalational Agents: e.g sevoflurane, Isoflurane, Enflurane, cyclopropane. etc..
- Treatment:
  - Stop all Anaesthetics. If possible, shift to new Anaesthesia machine or AMBU bag / breathing circuit without any traces of inhalational agents.
  - Hyperventilation with 100 % oxygen.
  - Control temperature by ice cooling, ice cold saline.
  - Correct acidosis.
  - Correct electrolyte imbalance.
  - Maintain urine output.
  - Dantrolene sodium: 2 mg/kg, to be repeated every 5 min. to maximum 10 mg/kg
  - Malignant hyperthermia though very rare causes increased morbidity and mortality
- **Complications related to Positions:**
- **Supine Position:**
  - Pressure on & stretching of arm must be avoided.
  - Leg should be flat, avoid pressure on calf veins.
  - Lumber support prevents postoperative backache.
- **Lithotomy Position:**
  - Decrease vital capacity up to 18%.
  - Muscle & nerve injury: Peroneal, Saphenous, Femoral, Obturator.
  - Increase cardiac load.
- **Trendelenburg Position:**
  - Increase cardiac load due to increase venous return.
  - Decrease VC & FRC.
  - Increase CVP, ICP, IOP.
- **Eye Complications:**
  - Corneal abrasion most common.
  - Vitreous haemorrhage, Retinal emboli, Transient blindness etc.
- **Renal / Hepatic System:**
  - Affected if hypotension or drug induced.
- **Anaphylactic Reaction:**
  - Perioperative anaphylactic reactions are life threatening anaphylactic reactions generally triggered by IgE mediated immediate hypersensitivity type of reaction.
  - Though difficult to exactly pinpoint, the incidence ranges from 1 in 10000 to 1 in 150000



anesthetics. The mortality ranging from 2 to 5% approximately.

- The Anaphylactic reactions can be mild to severe form and many classifications are used for the same. However irrespectively in moderate to severe reaction, a cardiovascular collapse (shock) with tachycardia, mucocutaneous edema and airway hyper reactivity can be seen with variety (cardiac being the most common)
- The most common culprits in perioperative setup are antibiotics and neuromuscular blocking agents (though almost any of the drugs can cause anaphylaxis)
- Variation in Temp, Tachycardia, Hypotension, Bronchospasm.

- **Management:**

- Discontinue any known clear stimuli suspected to cause anaphylaxis
- The ABC approach helps in managing severe form of anaphylactic reactions with call for help sent early.
- Airway should be secured and 100% FiO<sub>2</sub> provided at early stages.
- The mainstay of therapy is parenteral liberal amount of fluids (almost upto 20 to 30ml of volume can be given wherever not contraindicated) to fill up the dilated vessels (vasodilatory shock) along with epinephrine
- Epinephrine should be used IV wherever feasible and if IV access is not available the next best route preferred is IM
- There are various dosing regimens. Once common regime is to use the 50microgram bolus and followed by 100 to 200microgram bolus repeated in 3 to 5 minutes. If no significant response is noted after three boluses, its wise to start adrenaline continuous infusion at the rate of 0.05 to 0.1microgram / kg / minute
- Steroids, Antihistaminic roles come after acute stabilization and they are more for preventing next attack rather than helping priority with the ongoing anaphylactic shock as first line treatment
- The case should be documented and should be sent to higher center for allergy testing and management under expertise care. The patient should be counselled about the incident so that they can tell it as important part of their medical history whenever any intervention is planned.

- **Occupational Hazards:**

- Chronic exposure to anaesthetic gases.
- Infectious diseases.
- Substance abuse potential.
- Radiation exposure.

- **Preventable Anaesthetic Accidents:**

- Patient safety and quality improvement in Anaesthesia has always been on the forefront.
- Though there are multiple ways of how quality can be improved (patient safety and quality improvement recognized as a stream in its own), a simple basic requirement is of understanding that:

A. There is quality issues and safety related problems.

- B. How do we identify the problem?
- C. Classify, break them into small components and then identify the problems which can be corrected and then intervene.
- D. Keep on reevaluating the interventions which are being done.
  - Few common examples
- **Human errors:**
  - Unrecognized breathing circuit disconnections.
  - Mistaken drug administration.
  - Airway mismanagement.
  - Fluid mismanagement.
  - Anaesthesia machine misuse.
  - IV line disconnection.
- **Equipment Malfunction:**
  - Breathing circuit.
  - Monitoring device.
  - Anaesthesia machine.
  - Laryngoscope.
  - Ventilator.

### KEY LEARNING POINTS:

- Complications even with best of care will occur due to multiple factors in any clinical branch of medical sciences whenever patient care is being done, however the importance lies in being vigilant, in anticipating them and thus trying best to prevent them, even if they occur to identify them at the earliest and treat them effectively.
- It is not always possible to have exact diagnosis of complication being made at the initial phase of resuscitating a patient while complication has occurred. It is important that syndromic approach and initial emergency management is started while investigations and provisional differential diagnosis are being rapidly worked upon.
- Basics of ABC management should always be followed upon while managing any emergency.
  - A. – Airway: Patency and Protection
  - B. – Breathing: SpO<sub>2</sub> of more than 94% with oxygen therapy
  - C. - Circulation: Maintain MAP of more than 65 at least by use of fluids and vasopressors as appropriate
- At the earliest opportunity, call for help is an invaluable step while managing a life-threatening complication.
- Role of simulation-based training to manage common life-threatening complications is very valuable. Not only the doctors but the paramedical staff also needs to be trained so that everyone is clear about the roles they need to play while dealing with a emergency and can work together as a team with goal to improve patient outcomes.

## CHECK YOUR PROGRESS:

- Q1. Outline the ABC approach for managing any emergency.
- Q2. Enlist common pulmonary complications related to Anaesthesia and surgery. Describe approach for management of a hypoxic patient perioperatively.
- Q3. What are the common perioperative cardiovascular complications which can be encountered? Please write in details management of shock perioperatively.
- Q4. Describe approach to a patient with Brady arrhythmia.
- Q5. Spinal and Epidural haematoma associated with Anesthesia: write a short note.
- Q6. Write a short note on perioperative Anaphylaxis.

## References:

1. Miskovic, A. B. Lumb, Postoperative pulmonary complications, BJA: British Journal of Anaesthesia, Volume 118, Issue 3, March 2017, Pages 317–334, <https://doi.org/10.1093/bja/aex002>
2. American Heart Association Guidelines for Cardiopulmonary Resuscitation and Emergency Cardiovascular Care – Part 7: Adult Advanced Cardiovascular Life Support. Copyright © 2015 American Heart Association, Inc.
3. <https://cpr.heart.org/en/resuscitation-science/cpr-and-ecc-guidelines/algorithms>
4. Chestnut's obstetric anesthesia textbook.

# Week 8 - Module

## Systemic Disease- Part I



# 29

## Hypertensive disorder of pregnancy

### INTRODUCTION

#### Hypertensive disorders in pregnancy include

- Gestational hypertension (hypertension after 20 weeks of gestation with no proteinuria)
- Pre-eclampsia (hypertension with proteinuria or without proteinuria if other features of severity present)
- Eclampsia (pre-eclampsia with superadded convulsions)
- Chronic hypertension (hypertension antedating pregnancy or before 20 weeks of gestation and persisting postpartum)
- Chronic hypertension with superadded pre-eclampsia or eclampsia
- Prevalence of hypertension in pregnancy in India – 6.9 %
- Hypertension is defined as
  - A BP of  $\geq 140/90$  mmHg on at least two occasions 4 hours apart after 20 weeks of gestation.
  - An increase in diastolic pressure is more significant because, as unlike the systolic pressure, it is not affected by posture or excitement.
- Proteinuria is defined as
  - A protein concentration of  $\geq 300$  mg/L or protein/creatinine ratio  $> 0.3$  or Dipstick reading of  $\geq 1+$  (if other quantitative methods not available)
- When proteinuria is present with a normal BP, it usually does not indicate pre-eclampsia but could indicate urinary tract infection (UTI), kidney disease or contamination of the sample and is also found after prolonged standing.

### LEARNING OBJECTIVE

1. Identify hypertensive disorder of pregnancy
2. To be able to stabilise and successfully manage patients coming with eclampsia
3. To know briefly about antihypertensive agents used in pregnant women, magnesium sulphate and other drugs used for management of the hypertensive disorder of pregnancy
4. Anaesthetic concerns of physiological and pathophysiological changes
5. Perioperative and acute care management of such patients
6. Early and timely referral of severe cases which may require multidisciplinary or tertiary care management.



## PATHOPHYSIOLOGY OF PRE-ECLAMPSIA

- It is related to vascular dysfunction of the placenta that results in abnormal prostaglandin metabolism.
- Patients have elevated levels of thromboxane A<sub>2</sub> (vasoconstrictor that promotes platelet aggregation) and decreased prostacyclin (inhibitor of platelet aggregation). Endothelial dysfunction causes decreased levels of nitric oxide and increase endothelin-1 (vasoconstrictor and activator of platelets).
- Elevated vascular reactivity and endothelial injury propagates reduced placental perfusion and can lead to widespread systemic signs.

## SYSTEMIC MANIFESTATIONS OF PREECLAMPSIA (MORE WITH SEVERE FORMS)

### Central Nervous System

- Headache
- Hyperexcitability,
- Hyperreflexia,
- Coma.
- Visual disturbances like scotoma, amaurosis, and blurred vision.

Hyperperfusion of the brain in the presence of the endothelial dysfunction make them prone to vasogenic oedema.

### Airway

- The internal diameter of trachea reduced due to mucosal capillary engorgement
- Exaggerated in pre-eclampsia – pharyngolaryngeal oedema and subglottic oedema
- Signs- dysphonia, hoarseness of voice, snoring, stridor

### Pulmonary Oedema

- Incidence- 3% of women with pre-eclampsia
- Possible reasons- Exaggerated decrease in plasma albumin concentration, increased vascular permeability, excess fluid resuscitation
- Signs and symptoms- breathlessness, desaturation, fine crepitations on chest auscultation

### Cardiovascular

- Increased vascular tone and increased sensitivity to vasopressors
- Hypertension, vasospasm, end organ ischemia
- Plasma volume decreases by 40 % in severe disease
- Hyperdynamic state- the majority have an increase in cardiac output- Hyper dynamic LV function, increased SVR associated with heart failure and diastolic dysfunction

### Haematologic

- Thrombocytopenia- Both quantitative and qualitative deficit. Platelet counts less than 100,000/

mm<sup>3</sup> occur most commonly in women with severe disease or HELLP (haemolysis, elevated liver enzymes, and low platelet count) syndrome and correlate with the disease process's severity

- Disseminated intravascular coagulation (DIC) occurs in some women with pre-eclampsia, generally in the setting of severe liver involvement, intrauterine foetal demise, placental abruption, or postpartum haemorrhage

### Hepatic

- Periportal haemorrhage and fibrin deposition in hepatic sinusoids- present as right upper quadrant or epigastric pain
- Manifestation can vary from mild hepatocellular necrosis to HELLP syndrome
- HELLP syndrome can be associated with subcapsular bleeding and risk for hepatic rupture.
- Spontaneous hepatic rupture is rare but is associated with a 32% maternal mortality rate.

### Renal

- Persistent proteinuria
- Changes in the glomerular filtration rate
- Hyperuricemia
- Oliguria - a possible late manifestation of severe preeclampsia and parallels the severity of the disease
- Progression to renal failure is rare and is mostly precipitated by hypovolemia, placental abruption, or DIC.

### Uteroplacental circulation

- Decreased uteroplacental perfusion due to increased resistance- may lead to foetal growth restriction

## Establishing the diagnosis

Symptoms and signs	Probable diagnosis
BP >140/90 mmHg before 20 weeks of gestation	Chronic hypertension
BP >140/90 mmHg before 20 weeks of gestation Proteinuria after 20 wks of gestation	Chronic hypertension with superimposed pre-eclampsia
Two readings of BP >140/90 mmHg taken at least 4 hours apart, after 20 weeks of gestation No Proteinuria	Gestational hypertension
Two readings of BP $\geq$ 140/90 mmHg but <160/110 mmHg, taken 4 hours apart, after 20 weeks of gestation Proteinuria > 1+ (> 300 mg/L)	Non-severe pre-eclampsia
BP $\geq$ 160/110 mmHg after 20 weeks of gestation, at least two readings taken 10 mins apart. BP may be $\geq$ 140/90 mm Hg with the presence of any of the features of severity Proteinuria may or may not be present with any of the features of severity	Severe pre-eclampsia



<p>Features of severity:</p> <p>Headache, new-onset cerebral/ visual disturbance, severe persistent right upper quadrant or epigastric pain</p> <p>Oliguria</p> <p>Thrombocytopenia (Platelet count &lt; 100000/ <math>\mu</math>L)</p> <p>Impaired liver function (liver enzymes twice the normal limits)</p> <p>S Creatinine &gt; 1.1 mg/dL or doubling of levels over previous levels in the absence of renal disease</p> <p>Pulmonary oedema</p>	
<p>Severe pre-eclampsia PLUS any two of the following:</p> <p>Headache (increasing frequency, unrelieved by regular analgesics)</p> <p>Vomiting</p> <p>Blurring of vision</p> <p>Pain in the upper abdomen (epigastric pain or pain in the right upper quadrant)</p> <p>Oliguria (passing less than 400 ml urine in 24 hours)</p> <p>Hyperreflexia (exaggerated knee jerk)</p> <p>Pulmonary oedema</p>	Danger signs of impending eclampsia
<p>Convulsions</p> <p>BP <math>\geq</math> 140/90 mmHg after 20 weeks gestation</p> <p>Proteinuria <math>\geq</math> 1+</p>	Eclampsia

## Principles of antenatal management

- Foetal and maternal surveillance
- Treatment of hypertension
- Seizure prophylaxis
- Decisions regarding route and timing of delivery

Delivery of the foetus remains the only cure for pre-eclampsia.

### Mode of delivery

- Vaginal route is the preferred mode of delivery
- LSCS may be done for
  - \* Deteriorating maternal condition
  - \* Adverse fetal condition
  - \* Failed induction
  - \* Other obstetric indications

### Indications of admission at FRU

- If systolic BP < 160mm Hg & Diastolic BP  $\geq$  100 mm Hg start anti-hypertensives & admit at FRU for investigation, evaluation & stabilization
- The following antihypertensive may be started (BP should be taken by MO/ Staff nurse).

- Tab Labetalol 100 mg orally twice/ thrice a day (maximum up to 2.4g in 24 hrs) or
- Tab Nifedipine sustained-release preparation 10 mg orally twice/ thrice a day (maximum up to 80 mg in 24 hrs)
- Monitor B.P. (twice a day).
- If the BP is controlled:
  - Allow the woman to stay at home if she can get a home BP monitoring daily, understands danger signs and can come to the hospital as soon as the need arises.
  - Ensure a bi-weekly visit to a health facility
  - Weekly assessment of liver enzymes, kidney function test & platelets
- If BP is not controlled
  - Keep woman in hospital for monitoring or refer her to a District Hospital/ Medical College for further follow-up
- If Systolic  $\geq$  160 mm Hg &/or Diastolic BP  $\geq$ 110 mm Hg admit her & manage as Severe Pre-eclampsia.
- If danger signs of eclampsia are present or features of severity appear- admit immediately.

#### Treatment of Acute Severe Hypertension in Preeclampsia/Eclampsia

Medication	Onset of Action	Dose
Labetalol	5–10 min	20 mg IV, then 40–80 mg every 10 min up to a maximum dose of 220 mg IV
Hydralazine	10–20 min	5 mg IV every 20 min up to a maximum dose of 20 mg IV
Nifedipine	10–20 min	10 mg PO every 20 min up to a maximum dose of 50 mg
Nicardipine	10–15 min	Initial infusion 5 mg/h, increase by 2.5 mg/h every 5 min to a maximum dose of 15 mg/h

Although Labetalol is the most preferred agent to be used, depending on the availability, other drugs can also be used and should be titrated to response. During treatment, another antihypertensive agent with different mechanisms of action can be used to get an adequate response; one should be careful while using multiple agents simultaneously as it can result in precipitous hypotension.

#### Seizure Prophylaxis

- The routine use of magnesium sulphate for seizure prophylaxis in women with pre-eclampsia with severe features is an established obstetric practice.
- It is recommended to administer a loading dose of 4 to 6 g over 20 to 30 minutes, followed by a maintenance infusion of 1 to 2 g/h.
- Magnesium sulphate should not be given as a bolus rapidly as it causes respiratory depression in mother & foetus
- Loading dose - Can be given safely to patients with renal insufficiency

- The infusion is continued for 24 hours postpartum.
- Monitor
  - Deep tendon reflexes (loss of patellar reflex first manifestation of symptomatic hypermagnesemia)
  - Respirations >12/minute
  - Urine output >100 mL over 4 hours
  - Consciousness
  - Blood Pressure

### Applied pharmacology of magnesium sulphate

- Magnesium sulfate is eliminated by renal excretion, and serum levels may become dangerously high in the presence of renal insufficiency.
- Other effects of hypermagnesemia include
  - Chest pain and tightness
  - Palpitations
  - Nausea
  - Blurred vision
  - Sedation
  - Transient hypotension
  - Rarely pulmonary oedema.
- In untreated patients, the normal range for serum magnesium concentrations is 1.7 to 2.4 mg/dL. The therapeutic range lies between 5 and 9 mg/ dL.
- Patellar reflexes are lost at serum magnesium levels of approximately 12 mg/dL.
- Respiratory arrest occurs at levels between 15 and 20 mg/dL, and asystole occurs when the level exceeds 25 mg/dL
- Preeclamptic women with renal impairment should be monitored closely because magnesium toxicity can occur with usual dosing regimens. Serial measurement of serum magnesium levels may be helpful in the management of women with renal dysfunction
- Treatment of suspected magnesium toxicity includes immediate discontinuation of the infusion and the intravenous administration of calcium gluconate (1 g) over 10 minutes.

### Anaesthetic Management of patients with pre-eclampsia

#### Pre-operative workup

1. Complete blood count: to look for evidence of thrombocytopenia, it is recommended to avoid regional techniques if the platelet count is below 100,000/ $\mu$ L.
2. Coagulation profile
3. Serum creatinine, blood urea nitrogen, serum electrolytes
4. Urine albumin

During pre-operative evaluation focus on four main parameters

- Airway

- Haemodynamics
- Coagulation status
- Fluid balance

### Anaesthetic Considerations

1. Platelet count and coagulation profile should be checked before regional anaesthesia is administered, and it is recommended to avoid regional techniques if the platelet count is below 100,000/ $\mu$ L.
2. Spinal anaesthesia is a reasonable choice for caesarean sections in a patient with pre-eclampsia.
3. Hypotension can be treated with small, titrated doses of vasopressors (Mephetramine Ephedrine, phenylephrine) may be used

### Indications for General anaesthesia

1. Severe ongoing maternal haemorrhage
2. Sustained foetal bradycardia with a reassuring maternal airway examination,
3. Severe thrombocytopenia or other coagulopathy, or
4. A combination of these indications.

Placental abruption, intrauterine foetal demise, and pre-eclampsia all increase the risk for DIC

5. Challenges
  - a. Securing airway
  - b. Avoiding hypertensive responses- Can cause cerebral haemorrhage and pulmonary oedema. Following modalities can have been found to reduce the laryngoscopy and intubation response:
    - Preservative-free IV lignocaine-1.5 mg/kg, 90 seconds before laryngoscopy
    - Labetalol- 0.25-0.5 mg/kg
    - Esmolol- 0.5- 2 mg/ kg
    - Opioids- inform neonatologist
    - Nitroglycerine or Sodium nitroprusside

The hypertensive response can occur during extubation too.
  - c. Drug interactions- e.g.-  $MgSO_4$

### ECLAMPSIA

- Eclampsia is defined as the new onset of seizures or unexplained coma during pregnancy or the postpartum period in a woman with signs and symptoms of pre-eclampsia and without a pre-existing neurologic disorder.
- Eclampsia can occur suddenly at any point in the puerperium; however, most seizures occur intrapartum or within the first 48 hours after delivery.
- Late eclampsia is defined as seizure onset from 48 hours after delivery to 4 weeks postpartum.
- The majority of eclamptic women have evidence of severe pre-eclampsia, but in 10% to 15% of cases, hypertension is absent or modest and/, or proteinuria is no detected.

### Risk factors

1. Young maternal age
2. Nulliparity
3. Multiple gestations
4. Molar pregnancy
5. Pre-existing hypertension
6. Renal or cardiac disease
7. History of severe pre-eclampsia or eclampsia

### Major maternal complications of eclampsia include

1. Pulmonary aspiration
2. Pulmonary oedema
3. Cerebrovascular accident
4. Venous thromboembolism
5. Acute renal failure
6. Cardiopulmonary arrest or death.

80% of patients will have premonitory neurologic symptoms, the most common of which are headache and visual disturbances.

### Mechanism of seizure

- Loss of cerebral autoregulatory mechanism
- Interstitial or vasogenic cerebral oedema
- Decreased cerebral blood flow

### Management of eclampsia

- Immediate goals are to stop convulsions, establish a patent airway and prevent major complications (e.g., hypoxemia, aspiration)
- Further management includes antihypertensive therapy, induction or augmentation of labour, and expeditious (preferably vaginal) delivery.

### Airway

- Turn the patient to the left side; apply jaw thrust.
- Attempt bag-and-mask ventilation ( $FiO_2 = 1.0$ ).
- Insert oral airway if necessary.

### Breathing

- Continue bag-and-mask ventilation ( $FiO_2 = 1.0$ ).
- Apply pulse oximeter, and monitor  $SpO_2$ .

### Circulation

- Secure intravenous access.
- Check blood pressure at frequent intervals.

- Monitor electrocardiogram.

### Drugs

- Magnesium sulphate
  - ✓ 4 to 6 g IV over 20 min
  - ✓ 1 to 2 g/h IV for maintenance therapy
  - ✓ 2 to 4 g IV over 10 min for recurrent seizures
- Antihypertensive agents
- Labetalol or hydralazine as needed to treat hypertension

### Anaesthetic Management

- Assessment of seizure control and neurologic function- The possibility of increased intracranial pressure is not a cause for concern if the patient remains conscious, alert, and free of seizures. Persistent coma and localising signs may indicate a significant intracranial pathologic process that could affect anaesthetic management.
- Maintenance of fluid balance- avoid overzealous fluid administration
- Blood pressure control- Antihypertensive therapy should be instituted if the systolic pressure is 160 mm Hg or higher, or if the diastolic pressure is 110 mm Hg or higher.
- Monitoring- Continuous pulse oximetry, BP, ETCO<sub>2</sub> (if GA), invasive monitoring (arterial blood pressure or CVP, if facility available), intake output. Foetal heart rate
- The anaesthetic plan should be tailored to each case. In stable eclamptic women (fully conscious, normal coagulation status, no recent seizures, treated with magnesium sulphate, and no organ failure), neuraxial analgesia/anaesthesia can be considered with close monitoring of blood pressure.
- Should operative delivery be required in a woman with ongoing seizures, General Anaesthesia is preferred with rapid sequence induction and intubation with thiopentone sodium and succinylcholine. Any of the modalities mentioned above can be used to reduce laryngoscopy and intubation response.

### Postpartum Management

The risks associated with severe pre-eclampsia do not end with delivery.

*Postpartum women are at significant risk for*

1. Pulmonary oedema- the risk is highest in the postpartum period
2. Sustained hypertension
3. Stroke
4. Venous thromboembolism
5. Airway obstruction
6. Seizures

Hence close monitoring on a monitored bed is required postoperatively.

### KEY LEARNING POINTS

- Hypertension in the first 20 weeks of gestation is called chronic hypertension while that

developing after 20 weeks is called Gestational hypertension

- To diagnose hypertension, BP should be  $\geq 140/90$  mm Hg on at least two occasions 4 hours or more apart.
- Pre-eclampsia is hypertension ( $\geq 140/90$  mm Hg) with proteinuria  $\geq 300$  mg/ 24 hrs developing after 20 wks of gestation. However, the presence of proteinuria is not essential if other features of severity are present.
- Pre-eclampsia is labelled as severe if any feature of severity like headache, blurring of vision, epigastric pain, oliguria, thrombocytopenia, deranged LFT or KFT and pulmonary oedema are present
- Eclampsia is Pre-eclampsia with superadded convulsions
- General management, control of BP, control of seizures, intensive maternal monitoring & delivery form the mainstay for management of Eclampsia.
- Magnesium sulphate is the drug of choice for control of convulsions
- Spinal anaesthesia can be given in the absence of contraindications
- Vigilant perioperative monitoring; careful handling of the airway, breathing and circulation, seizure prophylaxis or treatment, prevention and suppression of hypertensive surge and judicious fluid administration form the backbone of anaesthetic management in such patients.

#### Further reading

- Chestnut Obstetric Anesthesia
- Gestational Hypertension and Preeclampsia, Obstetrics & Gynecology: June 2020 - Volume 135 - Issue 6 - p 1492-1495 doi: 10.1097/AOG.0000000000003892



# 30

## Asthma and pregnancy

---

### INTRODUCTION:

- Bronchial asthma is a chronic inflammatory disease of airways characterised by bronchial hyper reactivity and variable degree of airway obstruction.
- It is diagnosed on the basis of clinical history, physical examination and pulmonary function tests including reversibility testing and measuring bronchial reactivity.

### LEARNING OBJECTIVES:

- To learn about pathophysiology, clinical manifestations, and treatment of asthma
- To be able to diagnose acute exacerbation of bronchial asthma
- To be able to treat acute episode of bronchial asthma peri-operatively using various treatment modalities
- To be able to conduct successful anaesthesia for patients coming with bronchial asthma.

**Definition:** Asthma is defined by presence of:

- Reversible airway obstruction.
- Airway inflammation
- Airway hyper responsiveness

### PATHOPHYSIOLOGY:

- Enhancement of contractility or impairment of relaxation of airway smooth muscle.
- Airway inflammation and oedema
- Mucous plugging of the bronchioles
- Changes in the function of the airway epithelium
- Neural imbalance

### Diagnosis:

**Medical History:**

- Symptoms: Wheezing, Cough, Dyspnea, Chest tightness.
- Pattern and severity of symptoms.
- Precipitating and aggravating factors.
- Duration and course of symptoms

### Physical Examination:

Auscultation: Wheezing and prolonged expiratory phase

### Laboratory Investigations:

Pulmonary Function Test: Useful to document the severity and establish the reversibility of obstruction.

### Pulmonary Function Tests in Patients with Asthma:

- Forced Vital Capacity (FVC) (The volume of gas exhaled after maximal inspiration) may be reduced in asthma
- Forced Expiratory Volume in 1 Second (FEV1) (The volume exhaled in the first second after maximal inspiration) may be reduced in asthma
- Bronchodilator response (BDR) testing- postbronchodilator increase in FEV1  $\geq 12\%$  or 200 mL

### Effects of Pregnancy on Asthma:

- Mild asthma is likely to become significantly more severe if prescribed medications are discontinued during pregnancy.
- Exacerbations of asthma during labour and delivery occur in 20% patients and occur more frequently after caesarean than vaginal delivery.

### Factors That May Improve or Worsen Asthma during Pregnancy

Improving factors -

- Progesterone induced relaxation of airway smooth muscle.
- Increased production of broncho dilating prostaglandins (PGE1 & E2)
- Higher circulating cortisol level.

### Factors that may Worsen Asthma

- Decreased sensitivity to beta adrenergic agonists.
- Increased production of broncho constricting prostaglandins (PGF2- $\alpha$ )
- Reduced sensitivity to circulating cortisol because of binding of steroid hormones (e.g. Progesterone) to cortisol receptors.

### Effect of Asthma on Parturient and Foetus

Some studies report increased incidence of preeclampsia, caesarean delivery, low birth weight infants, preterm labour, antepartum & postpartum haemorrhage and perinatal mortality

## Anaesthetic management pregnant patient with Asthma

Maternal hypoxia and hypocapnia will impair foetal oxygenation. Good control of asthma is important to minimise the adverse effect of the disease on pregnancy.

### Preoperative evaluation

It includes assessment of:

- Severity of Asthma.
- Symptom (shortness of breath, cough, wheezing).
- Medication she is on (inhaler  $\beta 2$  agonist, steroid, anticholinergics like Ipratropium bromide).

- Any events that can precipitate asthma (exercise, infection, allergen, stress, and exposure to cold).
- Drug allergy

### Treatment of Acute asthma during labour and Delivery

- Give supplemental oxygen by face mask
- Make sure the patient is well hydrated.
- Look any inciting cause that can precipitate bronchospasm (e.g., upper respiratory tract infection, exposure to allergen)
- Treat initially with inhaled (nebulised)  $\beta_2$  agonist like Salbutamol or Salmeterol.
- Subcutaneous terbutaline 0.25 mg may be given as an alternative drug. If no relief with this therapy
- Intravenous hydrocortisone 100-200 mg every 6 hours may be given. Intravenous aminophylline may be used if symptoms are not relieved with the above therapy (dose: loading 5 mg/kg over 30 minutes followed by 0.5 mg/kg/hr).

### Analgesia for labour and delivery

Adequate pain relief is very essential both during labour and delivery as pain of active labour can precipitate bronchospasm. Systemic medication can provide analgesia in the early phase of labour. However, in a more active and painful part of (i.e., later phase) labour this may not be sufficient and epidural analgesia may be necessary.

### Anaesthesia for Caesarean Section

- If possible, optimise the patient's clinical condition status before surgery.
- Continue medication for asthma till the time of surgery
- Respiratory monitoring during surgery

### Regional Anaesthesia

It is the technique of choice for caesarean section and it offers following advantage in asthmatic patient.

1. Avoiding general anaesthesia and endotracheal intubations, it decreases the incidences of bronchospasm
2. In awake patient, continuous verbal contact will make identification of respiratory difficult easier.

### General Anaesthesia

- It carries its due risk in parturient with asthma
- Rapid induction and intubation sequence used for caesarean delivery can precipitate bronchospasm
- Deep plane of anaesthesia is desirable throughout surgery
- Ketamine is a good induction agent in asthmatic patient as it causes bronchodilatation (Dose 1-2 mg). Broncho dilatation begins within 1.5 minutes and lasts for 6-8 minutes. But it causes sympathetic stimulation, which can cause an increase in maternal BP and heart rate. This effect makes ketamine a less favourable induction agent in hypertensive patient.

- Propofol is a good alternative. Propofol in the dose of 2-2.5 mg/kg reduces the incidence of bronchospasm, provided the patient is not allergic to egg or soyabean
- Thiopentone sodium holds risk for precipitating bronchospasm hence, to be avoided.
- Other techniques, which can reduce the incidence of bronchospasm after intubations are:
  - Intravenous Xylocard (preservative-free lignocaine) 2% (1-1.5 mg/kg I.V. about 90 seconds before laryngoscopy) decreases the incidence of bronchospasm.
  - Avoid manipulation of the airway until full skeletal muscle relaxation and adequate anaesthetic plane have been achieved.

### Peri-operative Treatment of Bronchospasm

- Look for kinking of tube if intubated, to confirm if the increase in airway pressure or increase in bag resistance is due to external compressions.
- Find out and remove any possible triggering agent.
- Deepen the plane of anaesthesia.
- Use high concentration of oxygen till bronchospasm is controlled.
- Inhaled bronchodilator can be given via the endotracheal tube (8-10 puffs).
- Consider
  - Ketamine
  - Inhalational Anaesthetic agents (Halothane, Sevoflurane)
  - IV hydrocortisone
  - Nebulised Adrenaline
  - Heliox
  - If no relief with the above therapy aminophylline infusion may be started at the dose given above

### Extubation

Inhaled bronchodilator and small dose of intravenous fentanyl or preservative free lignocaine before extubation can help minimize airway reactivity during extubation

### Obstetric Management in obstetrics patient

- Prostaglandins (PG) to be administered with caution (PGF<sub>2</sub>-α constricts airways)

### Management of PPH in asthmatic patients

- 15-methyl PG F<sub>2</sub> α (Carboprost) is a relatively contraindicated
- Ergot alkaloids (Methergin) used in treatment of PPH is associated with acute bronchospasm.
- Oxytocin, which does not significantly affect airways preferred.

Please refer to chapter on respiratory drugs for more details on the drugs.

### Further reading

Management of bronchospasm during general anaesthesia. Alex Looseley

### **CHECK YOUR PROGRESS**

Q1. Preoperative evaluation and optimisation of an asthmatic patient posted for caesarean section

Q2. How will you treat intraoperative bronchospasm?

# 31

## Diabetes Mellitus & Pregnancy

### INTRODUCTION

- Diabetes mellitus has become a common metabolic disorder in the recent times and its incidence keeps on increasing in the general population. It is estimated that it is found in almost 8% adult population worldwide.
- Diabetes mellitus is broadly classified as Type 1 diabetes mellitus i.e., absolute deficiency in insulin secretion, Type 2 diabetes mellitus where insulin secretion may be relatively decreased as well as insulin resistance in target tissues is increased and lastly Gestational diabetes. This is a oversimplification but it's still followed commonly.
- Gestational diabetes mellitus or pre-existing diabetes mellitus and concurrent pregnancy can have maternal as well as foetal concerns especially when not appropriately controlled.

### LEARNING OBJECTIVE

After going through this module, one should be able to describe the:

Learning Objective	Knowledge	Skills
<ul style="list-style-type: none"><li>• To diagnose Diabetes mellitus in pregnancy</li><li>• To understand the investigations needed for diabetes mellitus management</li><li>• To understand the referral criterion</li><li>• Anaesthesia Implications</li></ul>	✓	<ul style="list-style-type: none"><li>• Observe &amp; assist the management of these cases and note down the pregnant cases presenting for Anaesthesia with Diabetes mellitus in log- book.</li></ul>

### DIAGNOSIS & MANAGEMENT OF GESTATIONAL DIABETES MELLITUS

- Gestational Diabetes Mellitus (GDM) is defined as Impaired Glucose Tolerance (IGT) detected first time during pregnancy. Worldwide, 1 in 10 pregnancies is associated with diabetes, 90% of which are GDM, but in India rates of GDM are estimated to be 10-14.3% which is much higher than that in the West.
- Undiagnosed or inadequately treated GDM can lead to significant maternal & foetal complications. Maternal risks of GDM include polyhydramnios, pre-eclampsia, prolonged labour, obstructed labour, caesarean section, uterine atony, postpartum haemorrhage, infection and progression of retinopathy which are the leading global causes of maternal mortality.

- Foetal risks include spontaneous abortion, intra-uterine death, stillbirth, congenital malformation, shoulder dystocia, birth injuries, neonatal hypoglycaemia and infant respiratory distress syndrome.
- Immediate and long-term clinical effects of GDM are important contributors to the burden of non-communicable diseases in many countries. Moreover, women with GDM and their offspring are at increased risk of developing type 2 diabetes later in life.
- GOI endorses universal screening for GDM in all pregnant women in the community.

## PROTOCOL FOR INVESTIGATION

- Testing for GDM is recommended twice during ANC.
- The first testing should be done during first antenatal contact as early as possible in pregnancy.
- The second testing should be done during 24-28 weeks of pregnancy if the first test is negative.
- There should be at least 4 weeks gap between the two tests.
- The test is to be conducted for all pregnant women (PW) even if she comes late in pregnancy for ANC at the time of first contact.
- If she presents beyond 28 weeks of pregnancy, only one test is to be done at the first point of contact.
- If the test is positive at any point, protocol of management should be followed as given in this guideline.
- Single step testing using 75 g oral glucose & measuring plasma glucose 2 hour after ingestion.
- 75g glucose is to be given orally after dissolving in approximately 300 ml water whether the PW comes in fasting or non-fasting state, irrespective of the last meal. The intake of the solution must be completed within 5 min.
- A plasma standardized glucometer should be used to evaluate blood glucose 2 hours after the oral glucose load.
- If vomiting occurs within 30 min of oral glucose intake, the test must be repeated the next day. If vomiting occurs after 30 minutes, the test continues.
- The threshold plasma glucose level of  $\geq 140$  mg/dL (more than or equal to 140) is taken as cut off for diagnosis of GDM.

## MANAGEMENT OF GDM

- All PW who tests positive for GDM for the first time should be started on Medical Nutrition Therapy (MNT) for 2 weeks.
- After 2 weeks of MNT, a 2 hrs PPPG (post meal) should be done.
- If 2hr PPPG  $\leq 120$ mg/dL repeat test every 2 weeks in second trimester & every week in third trimester
- If 2hr PPPG  $\geq 120$ mg/dL medical management to be started as per guidelines
- Metformin or Insulin therapy is the accepted Medical management of PW with GDM not controlled on MNT.
- Insulin can be started any time during pregnancy especially if GDM is diagnosed before 20 weeks & MNT has failed.
- Metformin can be started at 20 weeks of pregnancy, if MNT has failed to control her blood sugar.



The maximum dose is 2 gm/ day in divided doses. If the woman's blood sugar is not controlled with the maximum dose of metformin & MNT, Insulin is to be added.

- If Insulin is required in high doses, metformin may be added to the treatment.
- At PHC, Medical Officer (MO) should initiate treatment & refer pregnant women with GDM to a higher centre if blood sugar levels are not controlled or there is some other complication.
- At CHC/DH/MC, a Specialist/Gynaecologist/Obstetrician/Physician/MO can start Metformin or Insulin.
- If 2hr PPPG is >200mg/dL at diagnosis, starting dose of insulin should be 8 units pre-mixed insulin.
- The dose of Insulin should be adjusted on follow-up and at the same time MNT must be followed. Frequency of monitoring to be decided by the treating doctor.
- Refer to higher centre if one or more of the following conditions are met:
  - Nausea & vomiting and not able to take food orally.
  - Fasting blood glucose >200mg/dL with or without insulin.
  - Fasting blood glucose >150 mg/dL or post breakfast >250 mg/dL even after giving insulin
  - Total dose of insulin (combined morning and evening dose) on each day exceeds 20 units
  - If pregnant women develop low blood glucose (hypoglycaemia) more than once in a day.
  - If pregnant woman refuses to take insulin injection

## **SPECIAL OBSTETRIC CARE FOR PW WITH GDM**

- Antenatal care of a PW with GDM should be provided by a gynecologist if available.
- In cases diagnosed before 20 weeks of pregnancy, a foetal anatomical survey by USG should be performed at 18-20 weeks.
- For all pregnancies with GDM, a foetal growth scan should be performed at 28-30 weeks gestation & repeated at 34-36 weeks gestation. There should be at least 3 weeks gap between the two ultrasounds, and it should include foetal biometry & amniotic fluid estimation.
- PW with GDM in whom blood glucose level is well controlled & there are no complications, should go for routine antenatal care as per GOI guidelines.
- If PW with GDM having uncontrolled blood glucose level or any other complication of pregnancy, the frequency of antenatal visits should be increased to every 2 weeks in second trimester & every week in third trimester.
- Monitor for abnormal foetal growth (macrosomia/growth restriction) and polyhydramnios at each ANC visit.
- PW with GDM to be diligently monitored for hypertension in pregnancy, proteinuria and other obstetric complications.
- In PW with GDM between 24-37 weeks of gestation and requiring early delivery, antenatal steroids should be given as per GOI guidelines i.e., Inj. Dexamethasone 6 mg IM 12 hourly for 2 days. More vigilant monitoring of blood glucose levels should be done for next 72 hours following injection. In case of raised blood glucose levels during this period, adjustment of insulin dose should be made accordingly.

## **FOETAL SURVEILLANCE IN PW WITH GDM:**

- PW with GDM is at an increased risk for foetal death in utero and this risk is increased in PW

requiring medical management. Hence foetal surveillance is required.

- Foetal heart should be monitored by auscultation on each antenatal visit.
- Labour & Delivery
- PW with GDM with good control of Blood glucose (2 hr PPPG < 120 mg/dl) levels may be delivered at their respective health facility.
- PW with GDM on insulin therapy with uncontrolled blood glucose levels (2 hr PPPG  $\geq$  120 mg/dl) or insulin requirement >20 U/day should be referred for delivery at CEmONC centers under care of gynecologist at least a week before the planned delivery.
- Timing of delivery: GDM pregnancies are associated with delay in lung maturity of the Foetus; so routine delivery prior to 39 weeks is not recommended.
- If a PW with GDM with well controlled plasma glucose has not already delivered spontaneously, induction of labour should be scheduled at or after 39 weeks pregnancy.
- In PW with GDM with poor plasma glucose control, those with risk factors like hypertensive disorder of pregnancy, previous still birth & other complications should be delivered earlier. The timing of delivery should be individualized by the obstetrician accordingly.
- Vaginal delivery should be preferred and LSCS should be done for obstetric indications only.
- In case of foetal macrosomia (estimated foetal weight > 4 Kg) consideration should be given for a primary cesarean section at 39 weeks to avoid shoulder dystocia.

### **SPECIAL PRECAUTION DURING LABOUR**

- Pregnant women with GDM on medical management (metformin or insulin) require blood sugar monitoring during labour by a glucometer.
- The morning dose of insulin/metformin is withheld on the day of induction/labour and the pregnant women should be started on 2 hourly monitoring of blood sugar.
- IV infusion with normal saline (NS) to be started & regular insulin to be added according to blood sugar levels.
- Immediate neonatal care for baby of mother with GDM
- All neonates should receive essential newborn care with emphasis on early breastfeeding to prevent hypoglycaemia.
- Newborns should be monitored for hypoglycaemia. Monitoring should be started at 1 hour of delivery and continued every 4 hours (prior to next feed) till four stable glucose values are obtained. The cut off capillary blood glucose for hypoglycaemia in normal birth weight newborn is <45 mg/ dL and <54 mg/dL in case of Intra-uterine growth restriction (IUGR), to initiate treatment.
- Neonate should also be evaluated for other neonatal complications like respiratory distress, convulsions, hyperbilirubinemia.

### **POST-DELIVERY FOLLOW UP OF PW WITH GDM**

- Women with GDM should be offered regular postpartum care after delivery.
- 75 g OGTT should be performed after 6 weeks.
- Test normal: Woman is counselled about lifestyle modifications, weight monitoring & exercise. Advise women to get annual screening for DM in NCD clinic as per protocol.

- Test positive: Woman should be linked with NCD program for further management.
- PW with GDM and their offspring are at increased risk of developing Type II Diabetes mellitus in later life. They should be counselled for healthy lifestyle and behavior, particularly role of diet & exercise.

## ANAESTHESIA IMPLICATIONS

- Anaesthesiologist services will be required if these patients need LSCS for delivery. Occasionally they also may be called for helping with resuscitative efforts in pregnant patients with diabetes mellitus who are having other complications.
- One of the ways in which the Major complications of diabetes mellitus on mother can be classified as following:
  - Acute
    - Hypoglycaemia
    - Diabetic Ketoacidosis
  - Chronic
    - Macrovascular
      - Coronary complications e.g., IHD
      - Cerebrovascular complications e.g. Stroke
      - Peripheral vascular complications
    - Microvascular
      - Ophthalmology complications e.g. Diabetic Retinopathy
      - Nephrological complications e.g. Diabetic Nephropathy
    - Neuropathy
      - Somatic
      - Autonomic

## ANAESTHESIA PLANNING

### Pre-anaesthesia Checkup:

- Look for any complications of Diabetes mellitus, medication history as well as the trend of investigations (especially glycemic control) throughout the pregnancy period.
- Airway examination becomes important in parturient especially with long standing diabetes mellitus where diabetic stiff joint syndrome has been associated with difficult airway. i.e., difficult laryngoscopy and tracheal intubation.
- Long standing diabetes mellitus with evidence of autonomic neuropathy may need vasopressors during the Anaesthesia more commonly than non-diabetic patients.
- Non Invasive testing might help diagnose these autonomic dysfunction and one of the ways to do is to have a look at the frequent blood pressure measurements, corrected QTc intervals in ECG as well as pulse variation.
- These patients when kept NBM prior to elective procedure should have their medications for diabetes titrated and sugars checked overnight at least 4 hourly. They can be considered for overnight hydration with non-dextrose based crystalloid.

- Morning dose of antidiabetics should be omitted since these patients are NBM and morning sugars and if feasible potassium should be sent for investigation in early morning so that reports of the same are available prior to taking up in theatre.

### Plan of Anaesthesia:

- Neuraxial Anaesthesia is safe in these patients until and unless there is a compelling maternal or foetal indication for General Anaesthesia.
- OT preparation should be as usual along with extra care to have glucometer available in the OT along with D25 and DNS crystalloids available in event of hypoglycaemia.
- A good 18G bore IV line should be functional with IV crystalloid running. Normal saline is most commonly used.
- In Parturient with diabetes mellitus especially those patients who might have some component of autonomic dysfunction, vigorous hydration helps to decrease the maternal hypotension and this with adequate and prompt treatment of maternal hypotension helps in decreasing the neonatal complications like neonatal acidosis as well.
- In patients with evidence of autonomic dysfunction, it is important to look for gastroparesis and therefore anti-aspiration prophylaxis needs to be ensured.
- The Perioperative Sugars should be checked at least at one hourly interval and sugars tried to be maintained between 90 to 140mg/dl.
- Infection prevention becomes equally important in diabetic patients and therefore strict asepsis as well as other protocols to decrease the infection rates should be followed vigorously.
- In case if General Anaesthesia is required, routine drugs can be used safely with more frequent blood sugars measurement i.e., 30 to 60 minutes.

### KEY LEARNING POINTS

- Pregnancy is characterized by an increase (which is progressive) in the peripheral insulin resistance.
- Maternal diabetes mellitus is associated with increased incidence of maternal and foetal complications, strict glycemic control throughout the pregnancy helps decrease this complications
- Neuraxial Anaesthesia is safe in Diabetes. Adequate hydration, watch for complications, frequent blood sugar measurements and thereof control is important while planning anaesthesia for these patients

### CHECK YOUR PROGRESS

Q1. Classify Diabetes mellitus and define gestational diabetes mellitus. How will you investigate the suspected diabetes mellitus patient for diagnoses ?

Q2. Enumerate the maternal complications of diabetes mellitus in pregnant patients.

Q3. Write a short note on Anaesthesia plan for diabetes mellitus parturient planned for elective LSCS.

**Details of Diagnosis & Management of Gestational Diabetes Mellitus can be accessed at**  
[nhm.gov.in/nrhm-components/rmnch-a/maternal-health/guidelines.html](http://nhm.gov.in/nrhm-components/rmnch-a/maternal-health/guidelines.html)

# 32

## Anaemia and Pregnancy

---

### LEARNING OBJECTIVES

1. To identify anaemic patients and early medical management to prevent crises
2. To identify and document underlying pathophysiological manifestations or decompensation if any, before taking up for anaesthesia.
3. To be able to plan and successfully administer anaesthesia for anaemic patients coming for peripartum care.

### DEFINITION

- Anaemia in pregnancy is defined as Haemoglobin (Hb) level of  $<11$  g/dl during pregnancy (and in the immediate postpartum period).
- A pregnant woman with Hb level of  $<7$  g/dl is said to have severe anaemia.

### PATHOPHYSIOLOGY

- It can be a quantitative or qualitative (as in sickle cell disease) deficiency of red blood cells or Hb in circulation resulting in the reduced oxygen-carrying capacity of the blood.
- Compensatory mechanisms to increase arterial  $O_2$  content
  - Increase in cardiac output (CO)
  - Increase in respiratory rate ( $PaO_2$ )
  - Increased 2,3 diphosphoglycerate levels, a rightward shift in the oxygen dissociation curve (ODC) and decrease in blood viscosity to facilitate  $O_2$  delivery
  - Increased secretion of renal erythropoietin to promote erythropoiesis
- Parturients with severe anaemia with concomitant medical diseases (respiratory or cardiac) or those with acute ongoing blood losses may get decompensated, resulting in serious consequences like acute heart failure, myocardial ischemia or tissue hypoxemia.
- Preoperative evaluation should be aimed at assessing the severity and cause of anaemia.
- Acceptable Hb level will depend on the underlying medical condition, the extent of physiological compensation, the threat of bleeding and ongoing blood losses.
- Deposition of iron into endocrine tissues may lead to Diabetes Mellitus, adrenal insufficiency and infertility. Accumulation of iron in the myocardial tissue can lead to conduction abnormality and intractable heart failure.

## Clinical features

- Tiredness, easy fatiguability
- Breathlessness
- Conjunctival pallor
- Pallor of the tongue, palate and oral mucosa
- Severe palmar pallor
- Pedal oedema
- Tachypnoea
- Tachycardia, palpitations

The diagnostic framework to assess types of anaemia

Hb (in gm %)	Laboratory parameters	Interpretation
	≥11	• No anaemia
	10 - 10.9	• Mild anaemia
	7-9.9	• Moderate anaemia
	<7.0	• Severe anaemia
MCV/RBC count ratio	>14	• Iron deficiency anaemia
	≤14	• Thalassemia
Peripheral smear	Macrocytes and megaloblasts	• Megaloblastic anaemia
	Microcytes and hypochromia	• Iron deficiency anaemia or haemolytic anaemia
	A mix of microcytes and macrocytes/ megaloblasts	• Dimorphic anaemia
Serum ferritin (in µg/l)	<30 µg/l	• Iron deficiency anaemia

## Relevant history

1. Chronic or acute blood loss from GIT or female genital tract
2. Chronic disease associated with anaemia e.g.,- chronic renal failure, connective tissue disorders, infections, malignancy, diabetes, HIV and alcoholic liver disease
3. Conditions which can compromise O<sub>2</sub> delivery to tissues like obstructive or restrictive lung disease.

4. Ischaemic heart disease
5. Conditions causing compromised cardiovascular reserve, e.g., congestive heart failure.
6. Prior transfusion, treatment history
7. Nutritional habits and racial background
8. Family history of anaemia
9. History of worm infestations

### Treatment guidelines based on the period of gestation and Hb levels

Hb (g/dl)	10-10.9 g/dl	7-9.9 g/dl	<7 g/dl	<5g/dl
<ul style="list-style-type: none"> <li>• <b>First trimester (0-14 weeks)</b></li> </ul>	<ul style="list-style-type: none"> <li>• Folic acid 400 µgm</li> </ul>	<ul style="list-style-type: none"> <li>• Iron Folic Acid (IFA) (60 mg elemental iron and 0.5 mg folic acid) 1tab twice a day Patients in whom compliance to IFA tablets is likely to be low either due to intolerance or any other reason (high chance of loss to follow-up), IV Iron Sucrose can be considered as the first line of Management</li> </ul>	<ul style="list-style-type: none"> <li>• IFA (60 mg elemental iron and 0.5 mg folic acid) 1tab twice a day Consider BT if established heart failure</li> </ul>	<ul style="list-style-type: none"> <li>• Blood Transfusion (BT)</li> </ul>
<ul style="list-style-type: none"> <li>• <b>Second trimester (15-28 weeks)</b></li> </ul>	<ul style="list-style-type: none"> <li>• IFA (60 mg elemental iron and 0.5 mg folic acid) One tab twice a day</li> </ul>	<ul style="list-style-type: none"> <li>• IFA (60 mg elemental iron and 0.5 mg folic acid) 1tab twice a day Patients in whom compliance to IFA tablets is likely to be low either due to intolerance or any other reason (high chance of loss to follow-up), IV Iron Sucrose can be considered as the first line of Management</li> </ul>	<ul style="list-style-type: none"> <li>• IV Iron Sucrose Consider BT if established heart failure</li> </ul>	<ul style="list-style-type: none"> <li>• Blood Transfusion</li> </ul>
<ul style="list-style-type: none"> <li>• <b>Third trimester (29 weeks till term)</b></li> </ul>	<ul style="list-style-type: none"> <li>• IFA (60 mg elemental iron and 0.5 mg folic acid) One tab twice a day</li> </ul>	<ul style="list-style-type: none"> <li>• IV Iron Sucrose and then prophylactic IFA</li> </ul>	<ul style="list-style-type: none"> <li>• IV Iron Sucrose (If &gt;34weeks and Hb is &lt;7g/dl, blood transfusion is advised)</li> </ul>	<ul style="list-style-type: none"> <li>• Blood Transfusion</li> </ul>



## Anaesthetic Goals

1. Avoid
  - Drug-induced myocardial depression
  - Hypoxia- maintain a patent airway, preoxygenation for GA, oxygen supplementation perioperatively
  - Avoid and/or treat conditions increasing myocardial O<sub>2</sub> demand- tachycardia, shivering, pain, fever, acute haemorrhage
  - Hypovolemia- impaired tissue perfusion
  - Hypervolemia – acute LVF
  - Aortocaval compression
2. Minimize factors causing the leftward shift of ODC
  - Hyperventilation
  - Alkalosis
  - Hypothermia
3. Monitor tissue perfusion and watch for complications

Both general anaesthesia and spinal anaesthesia can be safely given to anaemic patients as per other deciding factors, provided coagulation profile is within normal limits.

- In patients with Vitamin B<sub>12</sub> deficiencies with neurological symptoms, central neuraxial blocks (worsening of symptoms of subacute degeneration of spinal cord) and nitrous oxide can be avoided.

## KEY LEARNING POINTS

- Anaemia in pregnancy defined as haemoglobin level of < 11 gm/dL during pregnancy (and in the immediate postpartum period)
- The main anaesthetic considerations are to optimize O<sub>2</sub> delivery, prevent any increase in oxygen demand and maintaining the adequacy of perfusion and oxygenation of vital organs
- Both GA and regional anaesthesia can be used.
- Judicious use of fluids and blood products- avoid both hypovolemia and hypervolemia
- Hypoxia, hypocarbia, hypothermia, acidosis and any conditions that shift the ODC to the left should be avoided

## Further reading

1. Grewal A. Anaemia and pregnancy: Anaesthetic implications. Indian J Anaesth 2010;54:380-6
2. Chestnut Obstetric Anesthesia

## BLOOD SAFETY CHECKLIST

1. Indication must be present for blood transfusion. It should never be ordered unless it is worth the risk.
2. It is always better to keep cross-matched blood ready for use but do not use without requirement.

3. Group and screen samples should be of <3 days old. A fresh sample is ideal.
4. Except for an emergency, only stored & screened blood should be used.
5. Blood of first relative / Siblings should not be transfused unless in an emergency.
6. Whole blood has no indication unless blood components are not available.
7. Patient's past H/O related to BT, indication, reaction to or any complication because of BT should be evaluated if any.
8. Blood bag must not be issued in advance and has to be issued only when requested and required.
9. All planned blood transfusions have to be performed during day time before 6 pm unless it is an emergency.
10. Cryoprecipitate is transported with ice packs.
11. Platelets should be gently shaking and should not be kept still during transport.
12. Blood received from blood bank can be stored in fridge (Refrigerator) but not in a deep freezer.
13. Red cells received should be started within 60 min of leaving controlled storage & completed in a maximum of 4 hours.
14. Visual inspection of the blood pack should be done. Check for any leak, clots, discolouration turbidity or haemolysis. If any check is failed, return the blood to the blood bank.
15. Informed and written consent for transfusion of blood/blood components to be taken. When transfusion of all or specific blood components is refused by the patient or relatives, this should be documented in the patient's clinical records.
16. The blood bag should be verified by the attending doctor/nurse. This should include the full name of the patient, blood group and Rh of both the patient & the donor, name of the component, date of tapping, date of expiry, donor reference number, patient's reference number, date & time of issue, volume, Blood bag number etc. The blood bag number should always be recorded on Anaesthesia chart/record.
17. ABO, rhesus D (RhD) & K (Kell) compatible red cell units, Platelets, FFP and Cryoprecipitate, should be transfused.
18. FFP & cryoprecipitate should ideally be of the same group as the recipient
19. Platelet concentrates should ideally be of the same ABO group as the recipient.
20. When platelet concentrates are in short supply, administration of ABO-nonidentical platelets is an acceptable practice. If RhD-positive platelets are transfused to an RhD-negative woman of childbearing potential, anti-D immunoglobulin should be administered.
21. Patient's identification has to be verified.
22. All aseptic precautions have to be taken. Hands have to be washed, and sterile gloves should be worn.
23. No 18 or 20 G I.V. Line on forearm / Central line should be taken.
24. Blood is administered with special BT administration set with micron filter.
25. Air should not be introduced into the administration set or the blood/blood components bag.
26. Blood warming is usually not required, but it is good to keep the patient warm. If blood warming is required (in massive or rapid transfusion) , use authenticated licensed blood warmer for it.
27. Monitor the vitals of the patient on blood/components transfusion. General condition, Pulse

rate, Temperature, Blood pressure and Respiratory rate should be monitored at the beginning, after 15 minutes of starting of BT, then regularly at every 30 min, at the end of BT and after one hour of completion of blood transfusion. It is good to monitor the oxygen saturation level if Pulse oximeter is available.

28. Proper hydration is to be maintained when a patient is on BT. Urine output to be monitored.
29. Monitoring chart has to be filled as per the measurement of monitoring parameters.
30. No drug has to be added to the blood or blood product. Medication has to be given from another access if required.
31. Signs for any blood transfusion reactions or complications should be watched for.
32. Preserve the Blood bag with label and BT set for a few hours.
33. Blood bag label to be stuck in nurses' note or patient case record as per the hospital policy.
34. Dispose of the blood bag & BT set as per Hospital Bio-medical waste management guidelines.
35. When the blood group is unknown, in an extreme situation, red cells of group "O -ve" can be given (although they may be incompatible for patients with irregular antibodies). In major obstetric haemorrhage, the provision of emergency blood with immediate issue of group O, Rh-negative & K negative units, with a switch to group-specific blood as soon as feasible.
36. In the case of simple, urticarial type reactions with no other symptoms or signs, the patient has to be given antihistaminic, and the transfusion may be continued at a slower rate.
37. If the patient has an unexpected transfusion reaction, Stop transfusion immediately. Call for the Help. Check and monitor vital signs and oxygen saturation. Maintain IV access (Do not flush existing line, change the IV Set, maintain IV access with NS and use new IV line if required).
38. Check that the right pack has been given to the right patient. Administer therapy appropriate to the adverse event. Inform the responsible blood bank and senior.

(Reference: RCOG and WHO recommendations)

# 33

## Pregnancy and Renal disease

### INTRODUCTION

- Pregnancy leads to reversible anatomical and physiological changes in the renal system.
- Depending on the biochemical markers, severity of the disease and co-existing systemic disease along with renal disorder plays an important role in tailoring anaesthesia for the patient into consideration.
- Physician /Nephrologist, Anaesthesiologist and Obstetrician need to evaluate the case with a multidisciplinary approach.
- It is beyond the scope of this curriculum to introduce the trainee to the nuances of managing a patient of advanced kidney disease and pregnancy presenting for a case needing anesthesia, however it is important that the trainee is able to identify the advanced renal disease at the earliest so that necessary planned transfer can be made in at the earliest opportunity to the tertiary centre. Also it will be important when such cases present in emergency (especially mild cases), and if the risk of transferring outweighs its advantages, the trainee should then be able to manage at least till the patient is stabilised and ready to be shifted.

### LEARNING OBJECTIVE

- After going through this module, one should be able to describe the:

Learning Objective	Knowledge	Skills
<ul style="list-style-type: none"><li>• To be able to identify patients at high risk for renal failure or patients with pre-existing renal disorder</li></ul>	✓	
<ul style="list-style-type: none"><li>• To be able to plan anaesthesia for patients with renal disorders, especially mild disease.</li><li>• To understand the drugs indicated as well as contraindicated in renal disorders. To understand the drug dosing modifications if needed during the same.</li></ul>	✓	<ul style="list-style-type: none"><li>• Observe, assist and note down the pregnant cases presenting for Anaesthesia with renal disease in log- book.</li></ul>

- Maternal as well as foetal health is affected in pregnant patients either with pre-existing renal disease or in those who had them occurring during the gestation.

### Physiological Changes in pregnancy related to Renal system

- Increased intravascular Volume
- Renal enlargement
- Dilatation of renal pelvis and ureters
- Obstruction of ureters at the pelvic brim
- Vesico-ureteric reflexes promoted so is the risk for ascending infection
- Renal blood flow is increased by 80%
- Glomerular filtration rate (GFR) is increased by 50%
- Consequently, Serum Creatinine falls therefore Creatinine value of more than 0.8mg/dl is taken as pathological (as compared to non-pregnant patient)

### RENAL PARENCHYMAL DISEASE / CHRONIC RENAL DISEASE

- Though Chronic renal diseases is not exactly similar to renal parenchymal disease, however it is easy to appreciate that many a times chronic renal disease will have renal parenchymal disease as the presentation aetiology.

### Broad classification

- Two subgroups of disorders – Glomerulopathies & Tubulo-interstitial disease
- Glomerulopathies further classified as
  - Nephritic Syndrome (Inflammatory / necrotising lesions)
  - Nephrotic syndromes (Abnormal permeability to macromolecules including proteins)
- Tubulo-interstitial disorders have abnormal tubular function leading to abnormal urine composition. Here the GFR decreases in late stage of diseases.
- It is important to note that Renal diseases as well as Preeclampsia both may manifest as hypertension, proteinuria and oedema. It is difficult to have a clear distinction between the two after 20<sup>th</sup> week of pregnancy.
- The available evidence suggests that pregnancy has a tendency to exacerbate kidney disease, however there is more exacerbation in patients who had already moderate to severe kidney disease before start of pregnancy.
- While the maternal complications involve gestational hypertension, preeclampsia – eclampsia as well as maternal mortality, adverse foetal events include still births, low birth weight as well as neonatal mortality.
- It is important that a multi-disciplinary team manages this and the Anaesthesiologist when sees this case for PAC should identify if the disease is moderate to severe enough so that a planned transfer to a higher centre can be made in liaison with the obstetrician.
- Regular Blood pressure measurements, watching for oedema, and biochemical markers of kidney function at regular intervals is of paramount importance. The Anaesthesiologist should note this in the pre-anaesthesia check-up OPD.

## Anaesthesia Management

- Organ specific concerns for Chronic renal failure and Anesthesia implications
  - Neurological
    - Uremic Encephalopathy
    - Seizure disorder
  - Cardio Vascular System
    - Hypertension
    - Cardiogenic pulmonary oedema
    - Uremic pericarditis
    - Fluid overload
  - Pulmonary System
    - Pleural effusions
    - Airway oedema
  - Metabolic – Haematologic
    - Hyperkalaemia
    - Acidosis ( Metabolic )
    - Anaemia
    - Platelet functional disorders
  - Gastro Intestinal System
    - Delayed gastric emptying
    - Increased gastric acidity
- Ultimately the Anaesthesia management depends upon the severity of the diseases and its effect on the end organ system for e.g. Hypertension, Pulmonary oedema and so on.
- Neuraxial anaesthesia is preferred mode in these patients, however the coagulation system contraindications need to be carefully looked for.
- Also, perioperatively fluid status is important to be evaluated. Hypovolemia is equally dangerous for these patients as is hypervolemia.
- Drugs need to be carefully used for especially the drugs which are renally excreted.
- Local anaesthesia toxicity is reported in patients of Chronic renal disease.
- NSAIDs use is contraindicated in the patients with CKD so are the Aminoglycoside antibiotics.
- For General anaesthesia, all the standard induction agents are safe in patients with renal failure. Uraemia though increases the blood brain permeability of certain drugs and therefore induction agents can be used in lower titrated doses. Suxamethonium use is relatively contraindicated and especially so in advanced renal cases where it will further exacerbate hyperkalaemia and might induce fatal arrhythmias secondarily. It is important to have serum potassium concentrations measurements before inducing a case, especially where time permits. Hyperkalaemia which is expected in advanced stages of renal failure might be exacerbated by Succinylcholine and therefore preoperative hyperkalaemia needs adequate treatment also. Succinylcholine normally causes a 0.5 to 0.7 mEq/L increase in potassium concentration. This is similar to the increment that occurs in patients without renal disease however in a kidney injury patient especially if the patient is already hyperkalaemic, this might then be sufficient to produce cardiac dysrhythmias.

- In such cases, even for induction provided that bag and mask ventilation is easy and when not contraindicated – e.g. patient is adequately NBM ( i.e no indication for rapid sequence induction), Atracurium or cis-atrcurium might be a suitable alternative for induction.
- For long-acting Neuromuscular blockade, Atacurium and Cis-atracurium are better drugs which undergo elimination through Hoffman’s elimination pathway and therefore can be used safely in these patients.
- It is important to note that many opioids have renal dependent excretion especially when used as repeat doses or as infusions (e.g. Morphine, Pethidine). Fentanyl is minimally excreted through kidney and may be a better choice, however caution must be still exercised. Regional anesthesia is a safe alternative for pain relief wherever possible.

## ACUTE KIDNEY INJURY

- It is a serious complication that can be seen during the gestation period.

### Aetiology

- The causes traditionally have been divided into pre-renal, Renal and post renal causes
  - Pre renal
    - Hypovolemia – hyperemesis gravidarum, obstetric haemorrhage
    - Acute heart failure causing hypo-perfusion
  - Renal
    - Pre-eclampsia / Eclampsia
    - HELLP syndrome
    - Septic abortion (one of the leading causes in developing countries)
    - Acute tubular necrosis
    - Drug induced Acute interstitial nephritis
    - Acute fatty liver of pregnancy
  - Post-renal
    - Urolithiasis

### Severity

- The Severity classification of Acute kidney injury (AKI) is done as per the KDIGO classification based on RIFLE criterion as follows

Stage	Serum Creatinine	Urine Output
1	1. 5-1.9 times baseline or increase in serum creatinine to $\geq 0.3$ mg/dL ( $\geq 26.5$ $\mu$ mol/L)	<0.5 mL/kg/h for 6-12 h
2	2.0-2.9 times baseline	< 0.5 mL/kg/h for $\geq 12$ h



Stage	Serum Creatinine	Urine Output
3	3 times baseline or increase in serum creatinine to $\geq 4.0\text{mg/dL}$ ( $\geq 353.6\ \mu\text{mol/L}$ ) or initiation of renal replacement therapy, or in patients $< 18$ years, decrease in eGFR to $< 35\text{mL/min/1.73m}^2$	$< 0.3\ \text{mL/kg/h}$ for $\geq 24\ \text{h}$ or anuria $\geq 12\ \text{h}$

KDIGO, kidney Disease: improving Global Outcomes; eGFR, estimated glomerular filtration rate. From Summary of Recommendation Statements. *kidney Int Suppl* 2012;2:8-12  
Source: Chestnut's Obstetric Anesthesia.

- A simple way to define AKI is
  - Increase in serum creatinine by  $0.3\text{mg/dl}$  OR
  - Increase in serum creatinine by 1.5 times the baseline OR
  - Urine output less than  $0.5\text{ml/kg/hour}$  for consecutive 6 hours
- Managing these cases needs its identification rapidly with regular clinical and lab follow up
- Treating the underlying cause while trying to optimise the kidney perfusion is the most important priority while managing these cases. In pregnant patients, its equally important to keep watch on foetus since these conditions are associated with significant foetal morbidity and mortality.
- Fluid, electrolytes, and drugs need to be optimised as mentioned above.
- Multidisciplinary team approach needs to be involved in managing these cases. It is imperative that when correctly identified and if the feasibility is there, these cases – especially those with deteriorating trend, are identified early and referred to a tertiary care centre with adequate facilities for better management.
- The choice of Anaesthesia in emergency will be dependent upon the factors mentioned above. Wherever feasible, and if not contraindicated, neuraxial anaesthesia is safer option.

## KEY LEARNING POINTS

- It is important that during the PAC visit by a patient, Anaesthesiologist identifies high risk cases which in time can be referred in elective fashion to higher centre for expectant management, Pregnancy with moderate to severe kidney disease are one of them
- Pregnant patient with moderate to severe kidney disease have significant chances that their kidney disease will worsen during the course of pregnancy and may have a life threatening hazard to their own health as well as the foetal outcome.
- Pre-eclampsia as well as kidney disease may present similarly, and it might be difficult to differentiate between the two especially after 20 weeks of gestation.
- Renal disease has tendency to involve other organ systems and its imperative that the Anaesthesiologist is familiar with them. Worsening status especially signs of Acute fluid overload, Acute pulmonary oedema, intractable and rising hyperkalaemia (especially with cardiac rhythm disturbances), Acute uremic encephalopathy, Acute uremic pericarditis, rising and worsening biochemical values including intractable and Severe metabolic acidosis are potential indications for renal replacement therapy. These can be instituted at higher centres under ICU care only.
- Anaesthesia management of pregnant patients with kidney disease depends upon the extent to which the severity is.
- Wherever feasible and not contraindicated (e.g. no coagulopathy) neuraxial anaesthesia is safe

option for Anaesthesia in these patients.

- Fluid, electrolyte management as well as judicious use of drugs in these patients is key to having a safe perioperative outcome.

### **CHECK YOUR PROGRESS**

Q1. Write short note about the Chronic renal disease and pregnancy – Anaesthesia implications

Q2. Define and classify Acute kidney injury. Enumerate causes.

Q3. Enlist in short, the specific organ system abnormalities occurring secondary to chronic renal failure that may affect the Anaesthesia management.

# Week 9 - Module

## Systemic Disease –Part 2



# 34

## Hemorrhagic disorder and pregnancy

### INTRODUCTION

- Obstetric haemorrhage is leading cause of maternal mortality worldwide, causing approximately 15% of all maternal deaths.
- Obstetric haemorrhage is most common cause for maternal admission to Obstetric ICU and Anaesthesiologist – obstetrician should be well aware to manage this complication. A multi-disciplinary team with great coordination and utilisation of skills goes long way to decrease morbidity and mortality associated with this complication.
- Anaesthesiologists with their life saving and acute emergency care skills training form an invaluable part of the team treating this complication.
- The Anaesthesiologist's main role is to maintain the haemodynamic stability and the Airway, Breathing, Circulation functions while preventing the adverse events associated with overzealous resuscitation while the obstetricians get the definitive method of achieving haemostasis. Massive transfusion protocol has already been discussed in the chapter of blood transfusion and readers are requested to go through the same again.

### LEARNING OBJECTIVE

- After going through this module, one should be able to describe the:

Learning Objective	Knowledge	Skills
Antepartum & Postpartum Haemorrhage: <ul style="list-style-type: none"><li>• Common causes</li><li>• Presentations</li><li>• Initial assessment – resuscitation</li><li>• The indications for surgical intervention in such conditions and the role of anaesthesiologist in the perioperative period.</li></ul>	✓	✓ <ul style="list-style-type: none"><li>• Observe, assist and note down the management done by the Anaesthesiologist and Obstetric team in pregnant cases presenting with Antepartum or post-partum haemorrhage.</li></ul>

## DEFINITIONS

- i. **Antepartum haemorrhage (APH):** Though the definition varies and can include any bleeding before the baby is delivered, the classical accepted definition is "Bleeding from the genital tract between 24 completed weeks and the onset of labour. Common causes are placenta praevia and placental abruption and they are discussed in details below.
- ii. **Postpartum haemorrhage (PPH) :** Though controversy exist regarding the definition of PPH, the commonly accepted definition is blood loss more than 500 mL after vaginal delivery or more than 1000 mL after caesarean delivery. Furthermore, the ACOG defines blood loss which are associated with signs or symptoms of hypovolemia to be enough to be labelled as PPH. Whereas WHO defines blood loss more than 500ml within time period of 24 hours of delivery irrespective of mode of delivery.

Furthermore, it is classified as Primary postpartum haemorrhage which occurs during the first 24 hours, whereas secondary postpartum haemorrhage occurs anytime between 24 hours and 6 weeks after delivery.

### Causes of Peri-partum Haemorrhage:

<b>Antepartum and intrapartum.</b>
• Placenta praevia.
• Abruption placenta.
• Uterine rupture.
• Trauma.
• Advanced ectopic pregnancy.
• Other genital tract bleeding.
<b>Postpartum.</b>
• Uterine atony.
• Retained placenta cervical and vaginal laceration.
• Placenta accreta.
• Uterine inversion.
• Coagulopathy.

<b>Aetiology of coagulopathy in obstetrics:</b>
• DIC secondary to: <ul style="list-style-type: none"> <li>■ Abruption placentae.</li> <li>■ Pre-eclampsia.</li> <li>■ Chorioamnionitis.</li> <li>■ Amniotic fluid embolism.</li> <li>■ Prolonged intrauterine death.</li> <li>■ Massive transfusion.</li> </ul>
• HELLP syndrome.
• Pre-existing disease.
• Iatrogenic (heparin).

## Ante-partum haemorrhage:

Few important causes will be discussed below. General Assessment & resuscitation for a bleeding parturient or patient of PPH is summarised at the end of the chapter.

### Placenta Previa:

#### Definition & Epidemiology

- Placenta Previa is present when the placenta implants in advance of the foetal presenting part, when the placenta covers the Cervix.
- Classically it was described as Total, partial and marginal however with the USG becoming common in the management of pregnancy, the precise localisation of the placenta can be seen now.
- Thus it is classified as Previa if any of the placental part is covering the Os, however if it is not covering the Os but lying close to the Os then it is described as low lying placenta.
- The Incidence about 1 in 200 pregnancies.

#### Diagnosis and obstetric considerations:

- Many of the placenta Previa which are diagnosed early in the pregnancy will later turnout to be normal placenta as the pregnancy advances (close to 90% will turn out normal)
- Classic sign is painless vaginal bleeding in the second and third trimester.
- Obstetric concerns are regarding the maternal and foetal well-being. Active labour, bleeding PV, mature foetal status are all indication to proceed with delivery. In absence of these conditions where feasible, expectant management can be considered and maternal corticosteroids considered for preterm gestation for foetal lung maturity.

#### Anaesthesia Considerations:

- Anaesthesiologist will be involved for either a planned or emergency LSCS or for a resuscitation of actively bleeding patient. The general management is discussed below.
- It is important that the Anaesthesiologist are involved in the care of patient at early stages, especially if any significant Antepartum haemorrhage is seen especially in third trimester. The primary job would be to help maintain vitals of the patient while the obstetrician team will decide for further obstetric plan (involving foetal and maternal well-being)

### Placental Abruptio:

#### Definition and Epidemiology

- Placental abruptio is defined as separation of the placenta from the decidua basalis before the foetus is delivered.
- Acute blood loss can cause foetal distress as the surface area of gas exchange between the foetus and mother is decreased.
- It is seen in 0.5 to 1.0% of all pregnancies.
- Diagnosis and foetal concerns:
- The classic presentation includes sudden vaginal bleeding, uterine tenderness and increased uterine activity.
- The major problem includes
  1. haemorrhagic shock
  2. coagulopathy



3. foetal distress.

- USG though specific is not very sensitive.
- The bleeding may be revealed as bleeding per vagina however can be concealed also behind the placenta and a high index of suspicion is needed.

#### Anaesthesiologist concern:

- Again, the Anaesthesiologist will be involved for either emergency LSCS or for resuscitation help in actively bleeding mother.
- The nature of LSCS is often Emergency in nature. The preoperative assessment and resuscitation are done as mentioned above. Often the patient requires immediate surgery because of foetal distress. Adequate restoration of intravenous volume is very important in the anaesthetic management. The general approach to managing Anaesthesia for expectant parturient with Antepartum haemorrhage is described below in more detail.

#### Postpartum haemorrhage (PPH)

- PPH is one of the leading causes of death in mothers and can occur even in the absence of any existing risk factors. In India incidence of PPH is about 5-8%
- Misuse of oxytocin during delivery can lead to PPH
- Atonic uterus is the commonest cause of immediate PPH
- Traumatic PPH is the second contributing factor to PPH.
- Immediate management requires early identification of signs of hypovolemia and providing appropriate care
- Active Management of third stage of labour is a preventive strategy to reduce PPH occurrence as it is difficult to predict which women will have PPH
- Use of Uterotonics is first line of management followed by mechanical intervention

#### Facility readiness

- Routine risk assessment of every woman during antenatal period
- Readiness of triage area, referral system within and outside the facility, blood bank, essential drugs and equipment and communication system.
- Obstetricians must Regularly monitor and follow up the patients during labour and postnatal period along with repair of all bleeding tears immediately.
- Routinely administer 10 IU Inj. Oxytocin, Controlled Cord Traction and uterine massage is highly recommended and is followed by the obstetrician.
- An Anaesthesiologist must be involved early in the case.

#### Definition

Postpartum haemorrhage is defined as the loss of 500 ml or more of blood from the genital tract after a vaginal delivery or in excess of 1000 ml in caesarean delivery.

Operational definition of PPH is the fully soaked more than one pad per hour or bright red bleeding with or without clots after delivery.



### Risk Factor for PPH

- Poor maternal nutrition
- Anaemia
- Inadequate antenatal supervision
- Mismanaged Third stage of labour
- Sometimes it may occur in women with no risk factor at all

### Prevention Strategies of PPH:

- Birth preparedness
- Early identification and management of anaemia
- Avoid unnecessary procedures (e.g., episiotomy)
- Active management of third stage of labour
  - Oxytocin 10 units IM
  - Controlled cord traction
  - Uterine massage
- Early identification and management of tears and lacerations.

### Types of PPH:

- ✓ Immediate PPH/primary PPH—during and within 24 hours of delivery. Most commonly caused by uterine atony. Other causes- include trauma to the genital track, retained placenta etc.
- ✓ Delayed PPH/secondary PPH—after 24 hours of delivery until six weeks postpartum. Commonly caused by retained placenta fragments.

### Aetiology of PPH

- Primary PPH:
  - Uterine atony 70-80%%
  - Tissue trauma – Perineal or cervical tear/ lacerations
  - Retained placental tissue or retained placenta
  - Coagulation defects
- Secondary PPH:
  - Retained placental bits
  - Metritis

### Identifying different types of PPH

Signs typically present	Signs Sometimes present	Probable cause of PPH
<ul style="list-style-type: none"> <li>• Immediate PPH</li> <li>• Uterus is soft &amp; not contracted</li> <li>• Bleeding may be continuous or intermittent</li> </ul>	Shock	Atonic uterus
<ul style="list-style-type: none"> <li>• Immediate PPH</li> <li>• Uterus contracted</li> <li>• Bleeding is continuous trickle</li> </ul>	Complete placenta on examination	Tears in the cervix or vagina
<ul style="list-style-type: none"> <li>• Placenta not delivered within 30 minutes after delivery</li> </ul>	<ul style="list-style-type: none"> <li>• Immediate PPH</li> <li>• Uterus relaxed</li> </ul>	Retained placenta

<ul style="list-style-type: none"> <li>A portion of the maternal surface of the Placenta is missing or the membrane are torn</li> </ul>	<ul style="list-style-type: none"> <li>Immediate PPH</li> <li>Uterus relaxed</li> </ul>	Retained placental fragments
<ul style="list-style-type: none"> <li>The uterine fundus is not felt on abdominal palpation</li> <li>Slight or intense pain</li> </ul>	<ul style="list-style-type: none"> <li>Inverted uterus (partial or complete) apparent at vulva</li> <li>Immediate PPH</li> </ul>	Acute uterine inversion
<ul style="list-style-type: none"> <li>Delayed PPH (Bleeding between 24 hours of delivery &amp; 6 weeks postpartum)</li> <li>Uterus softer and larger than expected for the elapsed time</li> </ul>	<ul style="list-style-type: none"> <li>Bleeding is variable (light/ heavy, continuous/ Irregular) &amp; foul-smelling discharge)</li> </ul>	Delayed PPH
<ul style="list-style-type: none"> <li>Immediate PPH (bleeding is intra-abdominal and/or transvaginal)</li> <li>Severe abdominal pain (may decrease after rupture of the uterus)</li> </ul>	<ul style="list-style-type: none"> <li>Shock (may be out of proportion to visible blood loss)</li> <li>Rapid maternal pulse</li> <li>Tender abdomen</li> <li>Uterine contour not felt</li> </ul>	Ruptured uterus

### Estimation of Blood Loss

- Signs of blood loss- Fast weak pulse  $>110$ / min, Rapid breathing ( $> 30$  breaths/min), Cold clammy sweat skin, restlessness, Anxious or confusion or unconscious, Systolic BP  $< 90$  mmHg, Urine ( $< 30$ ml/ hr.)
  - By the time a woman presents with systolic BP $< 90$ mmhg, she has already lost 1/3rd of the circulating volume (an average woman has 6 litres of blood in her circulation).
- Any women with or without any risk factors can have PPH.
  - Bleeding may occur at a slow rate over several hours; so it is important for the BEmONC officer to do continuous monitoring

Note: fall in BP is a late sign as mentioned in the below table as well. Blood loss can be estimated clinically or visually. It can be classified into 4 categories based on the severity as follows-

#### Clinical Estimation:

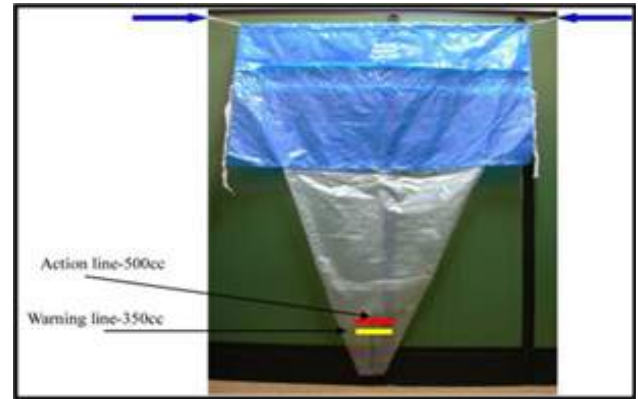
Clinical signs	Class I	Class II	Class III	Class IV
Blood loss(ml.)	500-1000	1200-1500	1800-2100	$>2400$
Pulse (beats/min.)	normal	100	120	140
SBP(mm of Hg)	normal	normal	60-80	60
MAP (mm Hg)	80-90	80-90	50-70	50
Tissue perfusion	Postural hypotension	Peripheral vasoconstriction	Pallor, restlessness, oliguria	Collapse, anuria, air hunger
Mental State	Slight Anxious	Anxious	Anxious and confused	Confused lethargic

## Visual estimation of blood loss-

Accurate measurement of the amount of blood lost after childbirth helps to quickly diagnose life-threatening haemorrhage. This can improve the timely management of PPH. Counting of large and small Mops soaked in blood and then approximating the blood loss is one of the crude but commonly employed methods.

## Calibrated Delivery Drape Sheet

- This is a calibrated drape to measure the volume of post-partum blood loss and is used after delivery of the placenta.
- The blood drape is a plastic sheet that is placed under the woman and siphons the blood into a calibrated measuring pocket on the sheet.
- The warning line is marked at 350 ml of blood loss and action line at 500 ml blood loss. The sheet is decontaminated and then disposed of as medical waste or incinerated after use.



## Assessment & Resuscitation:

- Anaesthesiologist services will be needed for either Anaesthesia requirement for procedure essential either for maternal or foetal or for both and ultimately to help achieve haemostasis or to help with resuscitation.
- Assessment and Resuscitation should be done simultaneously especially in patient with significant bleeding leading to symptoms and signs of shock.
- Identifying the shock severity on the basis of clinical signs as per the American Trauma Surgeons classification has been mentioned above.
- Resuscitation and brief relevant history – examination takes a priority in such cases before going to detailed history and other examination
  - Obstetric history to establish diagnosis.
  - Clinical signs:
    - Maternal: Level of Consciousness; Pulse; BP.
    - Foetal: heart rate; CTG
  - Loss: measured or concealed.
  - Obstetric examination: Speculum examination; ultrasound.
  - General medical history and examination: To assess fitness for anaesthesia.
- Send blood for cross match and arrange blood. At the earliest samples should be send for at least Complete Blood count (Hb and platelets at least) along with blood group, cross match and coagulation parameters of PT APTT INR which might be available as most common coagulation parameter of study at most places.
- Additionally, as feasible, should be sent for kidney function testing, liver function testing, Fibrinogen levels when and wherever feasible.
- Team Approach - Summon extra staff. It's a good thing to have your staff trained for such emergencies by doing regular mock drills and training impartation to the nurses, paramedics

and other medical officers.

- Position patient flat and give left lateral uterine tilt in antepartum cases.
- In Emergency approach the “ABCD of Resuscitation” as per details in the chapters on perioperative complications i.e to Maintain Airway patency and protected from aspiration, to Provide Oxygen to maintain oxygen saturations above 96% & to Keep the MAP appropriate
- **Maintaining Optimal perfusion:**
  - By Maintaining Intravascular volume & adequate cardiac output.
  - Intravenous access: Two large bore (16G / 18 G) cannulas.
  - **Fluid resuscitation:**
    - Warm Crystalloid are preferred (1-2 l).
    - Blood if available (Start with O Rh negative in case of emergency and cross matched blood is unavailable).
    - Warm fluid and blood while transfusing, to avoid hypothermia
    - Follow the principles of massive transfusion protocol if the need arises as mentioned in chapter of blood transfusion
  - **Vasopressors:**
    - Short acting agents like phenylephrine (50microgram boluses) or Mephentermine (3mg to 6mg boluses) are useful in early stage till definitive vasopressor agents like Noradrenaline are being made ready.
    - It is imperative to appreciate that in Hypovolemic shock (especially haemorrhagic shock) – the main treatment focusses on the replacement of volume with adequate bleeding control (surgical or interventional haemostasis) and role of vasopressors is secondary.
- Tranexamic acid 1gm IV stat at the onset of significant APH/PPH is an important consideration and should not be delayed until and unless absolutely contraindicated.
- Maternal monitoring which should continue uninterrupted should be:
  - **Essential:**
    - Oxygen Saturation
    - Pulse – ECG
    - BP
    - Sensorium
    - Urine Output
  - **Desirable:**
    - a. Temperature
- In case of APH and viable foetus, Foetal monitoring should be done as feasible by the Obstetrician.
- Continuous Assessment is very important to manage a bleeding patient. Continuous assessment of response to treatment is very essential by the treating team. Early help should be summoned and one should remember that definitive treatment is the control of bleeding in haemorrhagic shock and replacement of volume and other things are supportive in this till primary goal of haemostasis is achieved.
- At times in a haemorrhagic patient, the clinical condition demands that a patient is taken to the operation theatre – ultimately either for foetal delivery (in APH) or for definitive haemostasis for

actively bleeding mother or for both conditions.

- Indication for surgical treatment:
  - Delivery of foetus.
  - Delivery of placenta or retained products.
  - To repair local trauma or ruptured uterus.
  - To ligate vessel or perform hysterectomy in case of failed medical treatment.

### **Anaesthetic Management:**

- Assessment & resuscitation should be continued in peri-operative period also as mentioned above. Below is just a brief outline for Anaesthesia plan for bleeding patients.
- By this time a rapid PAC must have been already performed. It is very likely that the patients will not be nil by mouth (Full Stomach) and thus pre-disposing them to aspiration in case if need for General Anaesthesia occurs
- Informed written consent
- It is important that an informed consent for patient's operative procedure mentioning the risks associated with the Anaesthesia and the surgery is taken after counselling to patients and relatives.

### **Premedication**

- Anti-aspiration prophylaxis i.e. Pantoprazole 40mg IV and Inj Ondansetron 4mg IV and / or Inj Metoclopramide 10mg IV is given to the patient.
- If the patients is already on Vasopressor, same should be continued in the intraoperative room without stopping it during transport.
- Many cases in postpartum haemorrhage would be on oxytocin infusion, they should be continued after discussion with the obstetrician team including concerns of any side-effects if are seen.

### **OT preparation**

- As routine, OT should always be kept ready for emergencies at any time. This should become a routine habit to keep OT prepared.
- Emergency drugs, Crash cart, AMBU bag, Anaesthesia workstation, Suction machine should always be ready in OT.

### **Plan of Anaesthesia**

- The plan of Anaesthesia will depend upon the Maternal stability (vital signs) as well as the foetal status.
- An unstable maternal status i.e. a hypovolemic patient with active bleeding at the verge of impending shock or one already in shock needs to have GA considered for the operative procedure.
- Similarly, a dire foetal distress might also need a GA.
- However, in minimally bleeding patient, stable vitals and where foetal distress is not very severe

– especially in the backdrop of a patient who is not nil by mouth, neuraxial Anaesthesia in form of single shot spinal is very well tolerated and advocated.

- General anaesthesia is the technique of choice in a hypovolemic patient.
  - Thiopentone and propofol for induction may cause a severe hypotension in a hypovolemic patient so it is better to avoid it.
  - Ketamine (1-2mg/kg) and etomidate (0.3mg/kg) are a good choice.
  - Although theoretically, ketamine can cause an increase in uterine tone, which may cause a decrease in foetal perfusion in already distressed foetus however it is seen that a single induction dose of ketamine (up to 1 mg/ kg) is a safe induction agent. Severe hypotension associated with Thiopentone is more harmful than an increase in uterine tone caused by ketamine.
  - Since these patients are at risk of uterine atony, oxytocin (20 units in 1000 ml of Ringer Lactate through i.v drip but not as bolus) should be immediately infused after the delivery of the baby.
  - Persistent uterine atony may require other uterine ecbolic like methergine.
  - All inhalation agents relax the uterus with progressive depression of uterine contractility above 1 MAC. Above 2 MAC inhalational agents block the uterine response to oxytocic. Isoflurane 0.5 MAC or less does not cause uterine relaxation, and therefore is the agent of choice.
  - The principles of detail about general and spinal Anaesthesia can be found again the chapters in the curriculum

Below is a Maternal Early warning criteria which is useful in most of the maternal comorbidities to diagnose things and have a continuous monitoring.

**Table 1. The Maternal Early Warning Criteria**

Systolic BP (mm Hg)	<90 or >160
Diastolic BP (mm Hg)	>100
Heart rate (beats per min)	<50 or >120
Respiratory rate (breaths per min)	<10 or >30
Oxygen saturation on room air, at sea level, %	<95
Oliguria, mL/hr for ≥2 hours	<35

Maternal agitation, confusion, or unresponsiveness; Patient with preeclampsia reporting a non-remitting headache or shortness of breath

BP stands for blood pressure.

These triggers cannot address every possible clinical scenario that could be faced by an obstetric clinician and must not replace clinical judgment.

As a core safety principle, bedside nurses should always feel comfortable to escalate their concerns at any point.

From:

Mhyre, Jill M. MD; D’Oria, Robyn MA, RNC, APN; Hameed, Afshan B. MD; Lappen, Justin R. MD; Holley, Sharon L. CNM, DPN; Hunter, Stephen K. MD, PhD; Jones, Robin L. MD; King, Jeffrey C. MD; D’Alton, Mary E. MD The Maternal Early Warning Criteria, Obstetrics & Gynecology: October 2014 - Volume 124 - Issue 4 - p 782-786 doi: 10.1097/AOG.0000000000000480

## KEY LEARNING POINTS:

- Obstetric haemorrhage remains one of the leading causes of maternal morbidity and maternal mortality worldwide.
- While Antepartum haemorrhage represents a greater danger for foetal survival, postpartum haemorrhage represents greater danger to mother's life.
- It is important that the Anaesthesiologist and the obstetrician working together hold regular mock drills, training sessions and developed their team including nurses and other medical officers who would come together in such dire emergencies to save the precious lives.
- It is important to appreciate the fact that the visual blood estimation of the loss is often underestimated and therefore where feasible more accurate blood loss measurements like calibrated drains sheets, weighing machines, suction with markings be used.
- Similarly, due to young nature of age in these patients, the hypotension and tachycardia often come late in hypovolemia shock in these patients and these should be kept in back of mind when treating these patients
- Anaesthesiologist will be involved in these patient's services for either resuscitation or for Anaesthesia for a procedure needed for maternal and /or foetal wellbeing or for both. They should be well versed with the management of these cases.
- Team approach helps. It is important that in emergency scenario, standard protocols are followed and one of the protocols to be followed in such cases is the "ABCD resuscitation steps protocol."
- Most of the stable cases with minimal bleeding and stable vitals can be done with Neuraxial Anaesthesia but an actively bleeding patient with deteriorating vitals pointing to shock will need administration of General Anaesthesia more often than not. Ketamine in dose of 1mg/kg when not contraindicated would be a good option for induction of Anaesthesia in such cases given its hemodynamic profile.
- Securing good IV access, keeping OT Anaesthesia machine and emergency crash cart ready is vital to have successful outcomes to such cases

## CHECK YOUR PROGRESS:

Q1. What are the causes of peripartum haemorrhage ?

Q2. Write short notes on two of the antepartum haemorrhage causes – placenta Previa and Abruptio Placenta?

Q3. Define PPH and enlist common causes?

Q4. How'd you clinically classify the haemorrhage grade. Draw appropriate tabular diagram depicting these haemorrhage classes?

Q5. Write in short a general approach to assessment and resuscitation of bleeding patient /

Mhyre, Jill M. MD; D'Oria, Robyn MA, RNC, APN; Hameed, Afshan B. MD; Lappen, Justin R. MD; Holley, Sharon L. CNM, DPN; Hunter, Stephen K. MD, PhD; Jones, Robin L. MD; King, Jeffrey C. MD; D'Alton, Mary E. MD The Maternal Early Warning Criteria, Obstetrics & Gynecology: October 2014 - Volume 124 - Issue 4 - p 782-786 doi: 10.1097/AOG.0000000000000480



# 35

## Cardiac disease and pregnancy

In developing countries with a higher prevalence of rheumatic fever, the cardiac disease may complicate as many as 5.9% of pregnancies. 10%-15% of maternal mortality is attributed to cardiac diseases. Common causes of mortality include pulmonary hypertension, endocarditis, pulmonary oedema, thromboembolism, coronary artery disease, sudden arrhythmia, and cardiomyopathy/myocarditis

### Broad Classification of Cardiac Diseases Seen in Pregnancy

- Rheumatic heart diseases.
- Congestive heart failure.
- Valvular heart diseases.
  - Mitral/Aortic/Tricuspid/Pulmonary*
- Postpartum cardiomyopathy
- Ischemic heart diseases
- Arrhythmias
- Congenital heart diseases
  - Marfan syndrome*
  - Eisenmenger syndrome*
  - Fallot's tetralogy*
  - Cyanotic heart disease*

### RISK STRATIFICATION

Clark's classification of heart disease in pregnancy based on maternal mortality

#### Group 1: Mortality <1%

Atrial septal defect

Ventricular septal defect

Patent ductus arteriosus

Pulmonary/tricuspid disease

Corrected Tetralogy of Fallot

Bioprosthetic valve

Mitral stenosis, NYHA Class I and II

## Group 2: Mortality of 5%-15%

### Group 2A

Mitral stenosis NYHA Class III and IV

Aortic stenosis

Coarctation of aorta without valvular involvement

Uncorrected Tetralogy of Fallot

Previous myocardial infarction

Marfan syndrome with normal aorta

### Group 2B

Mitral stenosis with atrial fibrillation

## Group 3: Mortality of 25%-50%

Primary pulmonary hypertension

Eisenmenger syndrome

Coarctation of aorta with valvular involvement

Marfan syndrome with aortic involvement

## CARDIOVASCULAR CHANGES DURING PREGNANCY

- By term, plasma volume increases by 40%–50%, while red blood cell mass increases by 20%–30% leading to relative haemodilution
- More volume surge during labour, due to uterine contractions, pain & anxiety, transient auto transfusions with each contraction (~ 500 ml)
- Increase in blood volume immediately after birth, due to the release of compression on the inferior vena cava.
- Stroke volume, heart rate & cardiac output remain elevated for 48hrs after birth, return to the pre-pregnant state by ten days.
- Heart displaced upwards, to the left & may be some hypertrophy
- Systolic murmurs common & generally not pathogenic. (Diastolic murmurs are always pathological)
- Total peripheral resistance decreases because of high levels of oestrogens & progesterone.
- Nonspecific ST-segment and T-wave changes are common during normal pregnancy
- Plasma lipid concentrations (total serum cholesterol, triglycerides, and low-density lipoprotein cholesterol) concentrations, increase during pregnancy

## Cardiopulmonary Signs and Symptoms of Normal Pregnancy

- Easy fatigability and dyspnoea
- Tachycardia
- Increased respiratory rate and work of breathing
- Orthopnoea
- Chest pain – may be due to hiatus hernia, oesophageal reflux, or ribcage distension

- Syncope in later pregnancy- IVC compression, orthostatic hypotension
- Peripheral oedema, prominent neck veins
- Third heart sound, flow murmurs

## Symptoms and Signs of Heart Disease in Pregnancy

- Severe or progressive dyspnoea, progressive orthopnoea, paroxysmal nocturnal dyspnoea
- Haemoptysis
- Exertional syncope
- Chest pain related to effort or emotion
- Progressive or generalized oedema indicate
- Physical findings strongly suggestive of heart disease include cyanosis, clubbing, persistent neck vein distension, positive hepatojugular reflux, palpable thrill, diastolic murmurs, paradoxical splitting of cardiac sounds, true cardiomegaly, documented sustained dysrhythmias, and pulmonary hypertension (loud P2)

### New York Heart Association (NYHA) Functional status

Class
I. Dyspnoea only on severe exertion (with unaccustomed work).
II. Dyspnoea on mild exertion (with accustomed work).
III. Dyspnoea with daily routine activities.
IV. Dyspnoea at rest.

For class IV dyspnoea, consider delivery in centres with cardiac facility

## General Principles of Anaesthetic Management of the Parturient with Heart Disease

1. Good analgesia
2. Avoidance of aortocaval compression
3. Haemodynamic monitoring- Non-invasive BP (NIBP), electrocardiogram (ECG) for arrhythmias and heart rate, pulse oximetry, respiratory rate, signs of persistent respiratory distress, temperature, and input-output fluid balance; invasive CVP and arterial monitoring, if required
4. Optimizing cardiovascular and respiratory functions by manipulating various haemodynamic factors and tailoring anaesthetic technique for maternal and foetal well-being

### How to modulate haemodynamic parameters

Parameter	Increase	Decrease
Preload	IV fluids Mephenteramine Phenylephrine	Bleeding Capacitance vessels dilation- NTG PEEP
Pulmonary vascular resistance	Acidosis Increase PaCO <sub>2</sub> Hypoxia Pain Carboprost	Decrease PaCO <sub>2</sub> Increase PaO <sub>2</sub> Alkalosis Analgesia

Systemic vascular resistance	Mephenteramine Phenylephrine Ketamine	Arteriolar dilation- Nitroprusside, Isoprenaline Propofol Isoflurane, Sevoflurane Spinal, Epidural blocks
Heart rate	Anticholinergics- Atropine Pancuronium	$\beta$ blockers (Esmolol, Metoprolol), Digoxin Fentanyl, Vecuronium, Halothane
Contractility	Inotropes- Dopamine, Dobutamine, Adrenaline, Milrinone, Amrinone	$\beta$ blockers, Propofol, Halothane, Sevoflurane

PEEP: Positive end-expiratory pressure

- Preservation of sinus rhythm and aggressive treatment of any arrhythmias should also be paramount.
- 5. Drugs and equipment for resuscitation including airway and ventilatory management, if the need arises.
- 6. Anticoagulation therapy adjustments, if the patient is receiving for indications like mechanical valves, left atrial thrombus etc.

Discontinue warfarin 2-3 weeks before planned delivery and start continuous intravenous unfractionated heparin.

Oral anticoagulants like warfarin in 2nd and 3rd trimester.

Discontinue warfarin at 36 weeks' gestation and start dose-adjusted unfractionated (UFH) or low molecular weight heparin (LMWH). Replace LMWH at least 36 h before planned delivery and substitute with UFH. Discontinue UFH 4-6 h before planned delivery. It can be later restarted after haemostasis. (Further delayed in vaginal delivery).

- 7. Antibiotic prophylaxis for the prevention of infective endocarditis

## Infective endocarditis

- Endocarditis during pregnancy is rare.
- It is most frequently associated with intravenous drug use or pre-existing structural heart and valve abnormalities (e.g., rheumatic valvular disease, congenital heart disease).
- Maternal and foetal mortality rates are both high (approximately 15% and 22% respectively).

## Diagnosis of infective endocarditis

- The diagnosis of endocarditis rests on a very high index of suspicion, physical examination, laboratory findings, and cardiac imaging. The modified Duke criteria are the most widely accepted criteria for the diagnosis of endocarditis. Patients with endocarditis may have negative blood cultures. Therefore, the absence of bacterial growth in blood cultures does not automatically rule out endocarditis.

## Antibiotic Prophylaxis

- American Heart Association (AHA) recommend infective endocarditis antibiotic prophylaxis in patients with one or more of the following:

1. A prosthetic cardiac valve or a valve repaired with a prosthetic material,
  2. Unrepaired or palliated cyanotic congenital heart disease, and
  3. Surgically constructed palliative shunts and conduits.
  4. History of infective endocarditis.
- Antibiotic prophylaxis against bacterial endocarditis is necessary for both vaginal (at the time of membrane rupture) and operative deliveries.

#### Standard regimen.

Ampicillin 2 gm IV or IM and Gentamycin 1.5 mg/kg (up to 80 mg) IV or IM 30 minutes before; and Amoxicillin 1.5 gm orally 6 hours later or repeat IV regimen 8 hours later

#### Ampicillin/amoxicillin/ penicillin-allergic patient regimen.

IV administration of vancomycin 1 g over 1-2 h + IV or IM gentamycin 1.5 mg/kg (not to exceed 80 mg), complete injection/infusion within 30 min of starting the procedure.

- Alternative low-risk patient regimen Amoxicillin 2 g orally 1 hour before the procedure

### Potential problems at delivery/ caesarean section in parturient with heart disease

- Blood loss is poorly tolerated.
- Increased chances of bleeding, if concurrent anticoagulation.
- Higher chances of pulmonary oedema in the peripartum period due to fluid shifts. Careful fluid replacement is essential.
- Arrhythmias and tachycardia are poorly tolerated, so, drugs causing tachycardia (e.g. oxytocin, ephedrine) should be avoided or limited, Alpha-adrenergic agonists (e.g. phenylephrine) are the vasopressors of choice.
- Reduction in SVR by neuraxial blockade or drugs can cause problems in patients with fixed cardiac output (e.g. severe aortic stenosis) or in the presence of a shunt (ASD, VSD, TOF). Increase in the right to left shunting may reduce pulmonary blood flow and cause hypoxia.
- Meticulous care of IV lines to prevent air embolism.
- Increase pulmonary pressures can cause right ventricular failure and cardiac ischaemia. A drastic increase in preload may precipitate left ventricular failure.
- The risk of death is high in those with severe pulmonary hypertension.

#### Postpartum

- Patients with pulmonary hypertension or decompensated cardiac disease must be closely monitored postpartum for at least 72 hours as the majority of deaths in them occur after delivery.
- Fluid intake, output must be carefully monitored, anticoagulation re-established if necessary and good post-delivery analgesia maintained to prevent tachycardia and catecholamine increase.
- It takes 6-8 weeks for the cardiovascular system to return to pre-pregnancy function.

### Anaesthetic management of a patient with mitral stenosis (MS)

#### Goals

1. Maintenance of a low-normal heart rate and preservation of sinus rhythm; Aggressive treatment of atrial fibrillation (rate control), if present;

2. Avoidance of aortocaval compression.
  3. Maintenance of venous return
  4. Maintenance of adequate SVR.
  5. Prevent/ treat pain, hypoxemia, hypercarbia, and aci-dosis, which may increase PVR.
- Intraarterial monitoring and central venous access/filling pressure monitoring may be required in moderate to severe MS cases along with ECG (5 leads, if possible), SPO<sub>2</sub>, ETCO<sub>2</sub>, NIBP, temperature and input-output monitoring.

#### Neuraxial anaesthesia:

- It is well tolerated in patients with mild to moderate mitral stenosis (Valve area > 1.5 cm<sup>2</sup>, no pulmonary hypertension).
- Avoid fluid overload state intraoperatively, especially when autologous blood transfusion occurs after delivery of the placenta; roughly 700-800ml of blood gets pushed into maternal circulation at once.

#### General anaesthesia:

- Monitors, a large-bore, IV cannula.
- Preoxygenation with 100% oxygen (FIO<sub>2</sub>) by face mask for 3 to 5 minutes if time permits, or four maximally deep inspirations (vital capacity breaths) if time is limited.
- Rapid sequence induction (after a team "time-out" and abdominal preparation and draping) with thiopentone (titrated dose or 3-4 mg/kg) or etomidate (0.2 to 0.3 mg per kg) and succinylcholine (1 mg per kg); Propofol (2 mg per kg) can be used, but it may cause hypotension, making it a less ideal choice in this patient. Ketamine should also be avoided because it increases heart rate.
- Laryngoscopy response suppression- lignocaine (preservative free), esmolol, fentanyl.
- Maintenance—prior to delivery of the neonate N<sub>2</sub>O with 50% oxygen and volatile anaesthetic (e.g., 1% sevoflurane). If pulmonary hypertension is present, N<sub>2</sub>O should be avoided.
- Muscle relaxant (vecuronium, cisatracurium, or rocuronium), as needed.
- After delivery of the neonate- Midazolam, opioids.
- The aim should be to achieve a satisfactory balance between haemodynamic stability, maternal amnesia, adequate uterine tone and minimal neonatal depression.
- IV oxytocin infusion—begin immediately after delivery of the neonate. Bolus administration of oxytocin, methylergonovine, or 15-methyl prostaglandin F<sub>2α</sub> should be avoided.
- Tracheal extubation—after protective laryngeal reflexes have returned and the patient has regained consciousness .

#### Postpartum

- They are at risk of developing pulmonary oedema immediately postpartum as blood volumes expand due to contraction of the uterus and weaning off the vasodilatation effect of the neuraxial block, so fluids should be given with caution. Because of this high incidence of pulmonary oedema, one may give furosemide (Lasix) 20-40 mg IV with the delivery of the placenta.

## Specific goals in addition to general principles of management of heart disease for various conditions

### Aortic stenosis

- Maintain afterload- avoid hypotension
- Avoid tachycardia
- Monitor for ischaemia- decreased SVR in pregnancy, thickened LV myocardium may decrease coronary perfusion pressure
- Maintain normovolemia- because of LV diastolic dysfunction, excess of fluid may lead to pulmonary oedema
- Monitor for postpartum hypotension or ischaemia

### Mitral or aortic regurgitation

- Avoid an increase in SVR and decreased contractility- decreased SVR decreases the regurgitant volume
- Avoid bradycardia
- Maintain sinus rhythm
- Consider afterload reduction- neuraxial blocks are well tolerated if LV function is normal

### Left to right shunt (Atrial or ventricular septal defect etc.)

- Avoid
- Excessive fluid administration, extreme Trendelenburg position
- Increase in afterload
- Paradoxical air embolism

### Right to left shunt (Tetralogy of Fallot, Eisenmenger's syndrome etc.)

- Avoid decrease in afterload/ SVR- as it increases right to left shunting and thus cyanosis. Monitor oxygenation, invasive BP; careful titration of neuraxial anaesthesia & oxytocin; treatment of hypotension with phenylephrine
- Minimize PVR
- Maintain adequate blood volume and venous return- adequate RV preload will help in the ejection of blood past the obstruction to help achieve good pulmonary blood flow
- Avoid myocardial depression (RV contractility)
- Avoid paradoxical embolism
- Monitor in the postpartum period- cyanosis

### Severe LV dysfunction (dilated or peripartum cardiomyopathy)

- Avoid bradycardia- treat bradycardia with glycopyrrolate or ephedrine
- Avoid hypertension or hypotension
- Maintain contractility- Ephedrine; milrinone or dobutamine along with adrenaline or noradrenaline in low cardiac output states
- Strict monitoring of fluid balance and prevent/ monitor for pulmonary oedema (consider diuresis,



O<sub>2</sub>)

- Minimize PVR
- Monitor for postpartum heart failure
- Take expert cardiologist advice, if implanted cardioverter-defibrillator device (AICD) present
- Better to refer such patients, to tertiary care centres with round the clock cardiologist and intensive care facility available

#### Further reading

- Stoelting's Anesthesia and Co-existing disease

# 36

## Liver disease and Pregnancy

### INTRODUCTION

- Approximately 3% of pregnant women suffer from some form of liver disease during pregnancy. Though many conditions might be benign, unfortunately some of these conditions can be fatal for both mother and her child.
- Liver disease could be directly related to pregnancy, which can occur at a specific time during pregnancy. Another type is liver disease not related to pregnancy, which can occur at any time, such as viral or drug induced hepatitis. There could also be a third variety of liver disease, where pregnancy occurs in a patient with pre-existing liver disease.
- It is beyond the scope of this curriculum to introduce the trainee to the nuances of managing a patient of Severe Liver disease and pregnancy presenting for a case needing anesthesia, however it is important that the trainee is able to identify the advanced liver disease at the earliest so that necessary planned transfer can be made at the earliest opportunity to the tertiary centre. Also it will be important when such cases present in emergency (especially mild cases), and if the risk of transferring outweighs its advantages, the trainee should then be able to manage at least till the patient is stabilised and ready to be shifted. Thus, one needs to be familiar with various presentations and the need for early identifying early warning signs of the disease.

### LEARNING OBJECTIVE

- After going through this module, one should be able to describe the:

Learning Objective	Knowledge	Skills
<ul style="list-style-type: none"><li>• To be able to identify patients at high risk for Liver failure or patients with pre-existing hepatic disorder</li></ul>	✓	<ul style="list-style-type: none"><li>• Observe, assist and note down the pregnant cases presenting for Anaesthesia with liver disease in log book.</li></ul>
<ul style="list-style-type: none"><li>• To be able to plan anaesthesia for patients with hepatic disorders, especially mild disease.</li></ul>		
<ul style="list-style-type: none"><li>• To understand the drugs indicated as well as contraindicated in hepatic disorders. To understand the drug dosing modifications if needed during the same.</li></ul>	✓	

### It is imperative that Anaesthesiologist and the obstetrician

- Evaluate the extent of hepatic involvement by history and investigations.
- Recognize and evaluate underlying systemic abnormalities.
- Exclude or correct coagulopathy before administration of regional anaesthesia (Neuraxial).
- Prevent hepatic injury by optimizing hepatic blood flow and oxygenation.
- Recognize altered pharmacokinetics and pharmacodynamics.

### SYSTEMIC ABNORMALITIES ASSOCIATED WITH LIVER DISEASE

- Coagulation factors: Impaired synthesis of clotting factors I, II, V, VII and X, the plasma half-life of factor VII is 5 hours hence coagulopathy develops very rapidly. Vitamin-K administration corrects the abnormalities if due to malabsorption but cannot be corrected if it is due to liver failure. Coagulopathy must be corrected by transfusion of FFP, cryoprecipitate if clinical bleeding develops.
- Cardiovascular system: there is an increase in cardiac output due to low systemic vascular resistance secondary to extensive arterio-venous shunting. Hepatic failure results in an increase in blood volume that is greater than that occurs in normal pregnancy hence may develop cardiomyopathy. Tense ascites often seen in liver failure may impair venous return.
- Pulmonary system: impaired hypoxic pulmonary vasoconstriction along with ascites and splinting of diaphragm by the gravid uterus may lead to significant hypoxia. Patients with liver disease have an increase in 2, 3-DPG levels, hence a shift of oxygen dissociation curve to the right.
- Nervous system: Inadequate clearance of ammonia and mercaptans may lead to hepatic encephalopathy. Impairment may range from mild confusion to coma. These patients are at increased risk of pulmonary aspiration of gastric contents. The integrity of blood brain barrier is altered hence a careful titration of anaesthetic agent is required.
- Metabolic abnormalities: These include tendency to develop hypoglycaemia, hyponatremia, hypokalaemia and acid-base disturbances. Blood sugar should be measured frequently.
- Renal system: Abnormal sodium retention is usually present. Sudden oliguria may occur which heralds the onset of hepatorenal syndrome. Maintenance of adequate circulatory volume and monitoring of urine output is very important.

### LIVER DISEASES CLASSIFICATION IN RELATION TO PREGNANCY

- Liver diseases Incidental along with Pregnancy
  - Viral Hepatitis (A, B, C, D, E and G)
  - Cholecystitis
  - Liver abscess
  - Autoimmune hepatitis
  - Drug induced Hepatitis
- Liver diseases Specific to pregnancy
  - Hyperemesis Gravidarum
  - Intrahepatic Cholestasis of pregnancy
  - Pre-eclampsia / Eclampsia

- HELLP syndrome
- Acute Fatty Liver of pregnancy
- Acute Hepatic rupture (Haematoma)

DISEASE	Epidemiology Symptomology	Lab Findings	Treatment options	Complications
Viral Hepatitis	Asymptomatic, mild to fulminant course. Can present in any trimester	Deranged liver function tests – Liver enzymes (ALT, AST) will be raised depending upon severity along with bilirubin levels.	Expert opinion needed (Infectious disease specialist / Gastroenterologist / Internal medicine physician) Pre-exposure and postexposure prophylaxis and treatment in terms of antivirals, Interferons and immunoglobulins under expert opinion	Hepatitis A and E concurrent infection can have a significant mortality in pregnancy. Watch for long term complications like cirrhosis and hepatocellular carcinoma.
Intrahepatic Cholestasis of pregnancy	1 to 5 %. 2nd or early third trimester. Jaundice. Pruritis	Increased Bilirubin levels Mild derangement of other LFT	Expert opinion Delivery as normal on foetal maturity	Mostly benign for mother. Premature delivery with chances of foetal loss present
Pre-eclampsia / Eclampsia	Around 3 to 6% After 20 weeks of pregnancy. Watch for severe pre-eclampsia features especially right upper quadrant pain.	Thrombocytopenia. Mild derangement of LFT.	Depending upon the severity, expectant management. Deteriorating maternal condition indication for expedited foetal delivery	Liver Rupture carries high mortality, close to 20% Coagulopathy Increased hazard to mother and foetus
HELLP Syndrome	Around 0.5% to 1%. Abdominal pain AKI Hypertension	Thrombocytopenia. Hemolysis – LDH and peripheral smear. Elevated (quite significant) ALT and AST levels	At the earliest delivery of the foetus Supportive care in ICU to organ system till hepatic recovery	Increased risk of maternal and foetal mortality
Acute Fatty liver of pregnancy	1 in around 5000 to 7000 cases. Rare but with high mortality	Thrombocytopenia Elevated enzymes (ALT & AST) Hypoglycemia	At the earliest delivery of the foetus Supportive care in ICU to organ system till hepatic recovery	Increased risk of maternal (close to 10 to 15%) and foetal mortality

	Commonly misdiagnosed as HELLP syndrome at times Nausea, Vomiting, Hypoglycemia, Coagulopathy, decreasing urine output, Hepatic failure features			
--	---	--	--	--

## ACUTE LIVER FAILURE

- Extremely serious complication – because of any of the above-mentioned causes
- Can deteriorate very rapidly.
- Supportive Care mostly in ICU till hepatic recovery occurs, in some cases specific antidotes are available and in extreme cases Liver transplantation might be needed.
- Can lead to
  - Encephalopathy
  - Coagulopathy
  - Immune dysfunction predisposing to infections
  - Circulatory decompensation – distributive shock
  - Metabolic decompensation – Hypoglycaemia, metabolic acidosis
  - Acute Kidney Injury

## Chronic Liver Failure / Cirrhosis

- Features of portal hypertension
- Acute on chronic liver failure – decompensation
- Pregnancy is rare in patients who have pre-existing severe liver disease

## ANAESTHETIC MANAGEMENT:

- At times patients will present for delivery of foetus as this is the required treatment in advanced liver diseases
- The most important things is to determine the extent of disease and its end organ damage.
- For patients with moderate to severe disease and where feasible, the patients should be stabilised and referred to higher tertiary care centre for needful management.
- Multi-disciplinary team brings out the best of the results in such patients.
- Deciding on the type of Anaesthesia, following consideration should be done.

### Regional Anaesthesia:

- If no coagulation abnormalities, regional anaesthesia can be safely administered in patients with hepatic failure.

- Local anaesthetic of amide type, undergoes hepatic biotransformation and the half-life Lignocaine is found to be increased by more than three fold in hepatic failure and the volume of distribution is increased.
- Ascites and portal hypertension lead to engorgement of epidural veins, hence an increased incidence of bloody tap and the use of test dose to rule out intravascular injection is essential.

### General Anaesthesia:

- General anaesthesia is indicated when there are coagulation abnormalities, severe haemorrhage, foetal distress and altered sensorium.
- Evaluate intravascular volume before induction of anaesthesia. Patient with variceal bleeding should be intubated awake.
- Anaesthesia may be induced with thiopentone, or ketamine depending on the haemodynamic status of the patient. Pseudocholinesterase level may be reduced in liver failure, which causes a delay in the metabolism of succinylcholine but it is usually of minimal significance.
- Give non-depolariser (long acting) preferably atracurium only after the recovery of the effect of succinylcholine.
- Isoflurane is the preferred inhalation agent of choice. Reversal of neuromuscular blockade must be documented before extubation.

### KEY LEARNING POINTS

- Liver diseases are important to understand for Anaesthesiologist as they have perioperative anaesthetic implications
- Viral hepatitis is one of the most common cause of jaundice during pregnancy.
- Acute fatty liver of pregnancy and Acute hepatic rupture though rare are significant complications which carry a substantial mortality
- Anaesthesiologist during the preanesthetic check-up OPD should always try to identify if there are other systemic illness associated with the pregnancy and if identified, should try to gauge the severity based on clinical and laboratory findings.
- For patients with moderate to severe disease, it is imperative that they are referred to tertiary care centre whenever feasible
- Neuraxial anesthesia is safe in patients with liver disease provided that there are no coagulation abnormalities (rather than looking at one absolute value, it is more useful to have look at the trend of laboratory parameters)

### CHECK YOUR PROGRESS

- Q1. Enlist common causes of liver diseases seen during pregnancy
- Q2. Write a short note on Pre-anesthesia check-up evaluation in patient with existing liver disease
- Q3. Write a short note on Anaesthesia concerns in patients with liver disease

# 37

## Trauma and pregnancy

### INTRODUCTION

- Trauma during pregnancy accounts for 6-7% mortality in women in western population.
- It is one of the most common causes of maternal death other than medical complications of pregnancy, in fact in united states where the data is available this is the leading cause of non-obstetric death in an obstetric population.
- Both mother and foetus may face the consequences of trauma during pregnancy. Though the focus of trauma management remains largely similar i.e., primary survey to treat acute life threatening injuries followed by secondary survey, the pregnant patient's management differs in certain aspects as compared from non-pregnant women because of major physiologic changes that occur during pregnancy as well as foetal considerations.
- One should be aware of maternal physiologic adaptation to pregnancy. Apart from obvious trauma to pregnant women, transfusion of foetal blood into maternal circulation, abnormal separation of placenta, premature labour, foetal injury and Foetal death can occur. As with any other patient with trauma, early recognition and intervention is key to good outcome.

### LEARNING OBJECTIVE

- After going through this module, one should be able to describe the:

Learning Objective	Knowledge	Skills
<ul style="list-style-type: none"><li>• Describe Trauma epidemiology, complications and outcomes.</li></ul>	✓	<ul style="list-style-type: none"><li>• Observe, assist and note down the pregnant cases presenting for Anaesthesia with trauma in log-book.</li></ul>
<ul style="list-style-type: none"><li>• The initial assessment and resuscitation of the pregnant trauma victim, along with understanding the major similarities and differences in pregnant and non-pregnant population</li></ul>	✓	
<ul style="list-style-type: none"><li>• Foetal survey and resuscitation, Anaesthesia implications</li></ul>		



## EPIDEMIOLOGY

- Leading non obstetric cause of mortality in Western setup
- Trauma affects close to 5 to 7 % of all pregnancy in the West (data from Indian setup is lacking)
- Blunt injury more common.
- Road traffic accident most common cause.

## Anatomical & Physiological changes:

- Uterus enlarges in size and starts to get more blood supply. Therefore, uterine trauma can be dangerous for both mother as well as the foetus.
- Life threatening increase in uterus size, so more chances of blunt or penetrating injury – or:
  - First trimester: Well protected by amniotic fluid and thick walled uterus.
  - Third trimester: Less amniotic fluid and thin walled so more chances of trauma to the baby.

### Respiratory:

- Increased Airway oedema during later stage of pregnancy – difficult intubation Physiologic hyperventilation.
- Increase in tidal volume.
- Increase in respiratory rate.
- Mild respiratory alkalosis
- Increased oxygen consumption and decreased functional residual capacity (FRC) causes more rapid desaturation.

### Circulatory changes:

- Heart rate increases by 15%.
- Blood pressure decreases in initial stage.
- Cardiac output increases by 30-40%.
- Aorto-caval compression.
- Systemic vascular resistance decreases.
- Increase in intravascular volume, hypotension presents late before significant volume is already lost.
- Loss of circulating volume and haemorrhage are major physiologic challenges associated with trauma. The actual amount of blood loss that results in clinical manifestation of response is greater in pregnant patient than non-pregnant patient.
- Foetal tolerance of maternal haemorrhage depends on the degree of maternal sympathetic response, maternal blood pressure and oxygen carrying capacity.

## Outcomes and Complications in Trauma in Pregnancy

- Haemorrhagic shock and Traumatic brain injury by far remain the most common mechanisms of mortality in pregnancy related to Trauma.
- Though not complete, but a very simplistic way to classify outcomes and complications in

trauma in pregnancy can be

### Maternal Complications

- Traumatic Brain Injury
- Haemorrhagic Shock
- Pelvic and Acetabular injury
- Uterine Trauma (blunt mostly) – with Haemorrhage – 10% maternal mortality and almost close to 100% Foetal mortality
- Placental Abruption
- Preterm Labour
- Foetal – maternal haemorrhage leading to iso-immunisation can be seen commonly than expected and the Kleihauer-Betke test helps to diagnose the same.

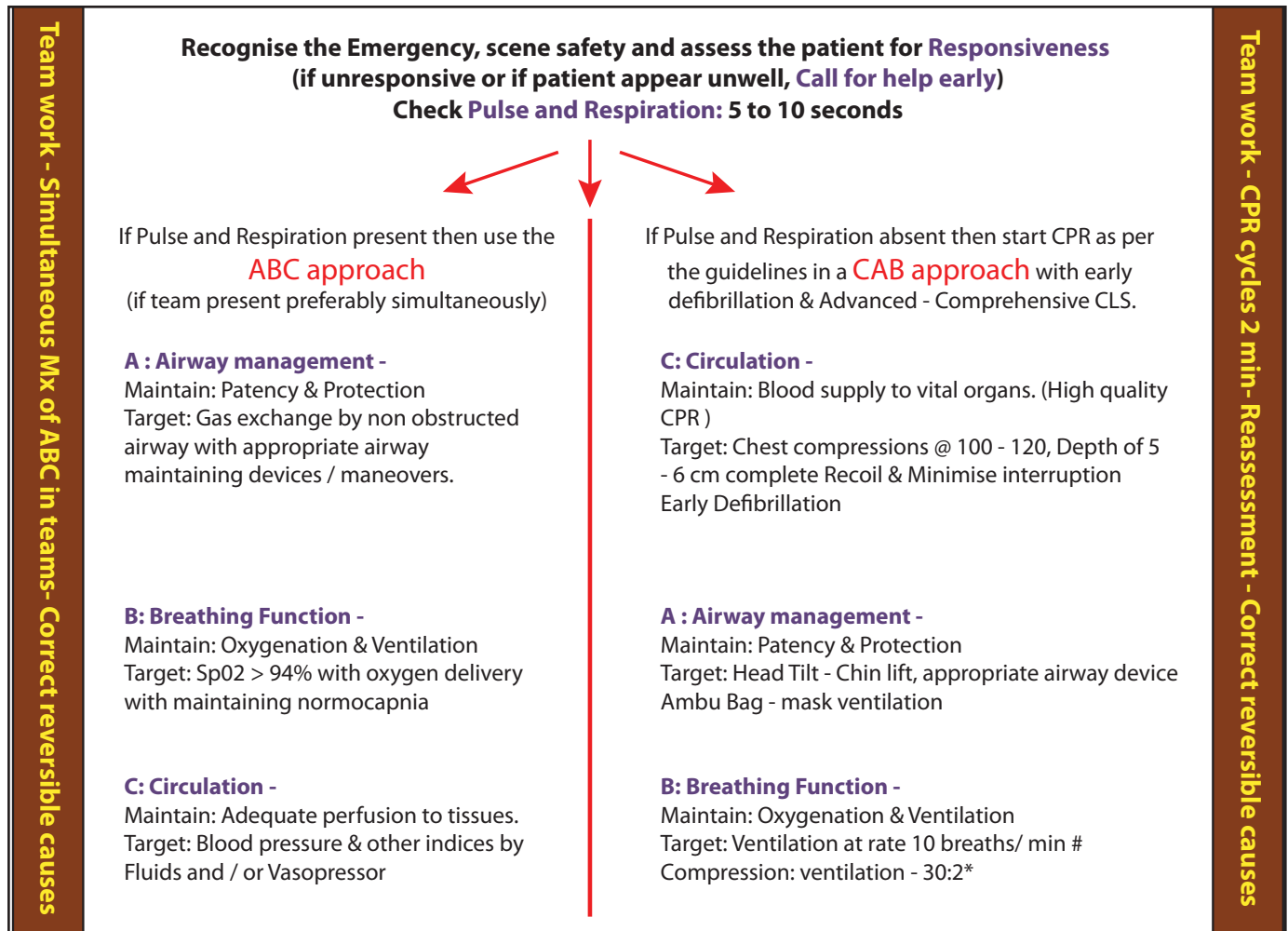
### Foetal Complications

- Foetal mortality rate after maternal trauma as reported in the literature varies from anywhere between 4 to 40% approximately and the causes are primarily related to uterine or placental trauma.
- Direct foetal skull fracture

## GENERAL PRINCIPLES OF INITIAL ASSESSMENT AND RESUSCITATION

- The principles of initial assessment and resuscitation as well as overall resuscitation does not differ much from non-pregnant patients, except for the few changes that are necessary because of the physiological changes in pregnancy which will alter the management in disease state as well as additional concern of assessment and management of the Foetus.
- It is crucial to look after the “standard ABCD” (See the figure below) as the initial Trauma assessment would do including utmost priority to preserve the maternal Airway, oxygenation as well as circulatory status i.e., cardiac output which in turn will also help for foetal resuscitation directly.
- It is imperative to understand and counsel the patients and relatives that even despite this, foetal loss can occur even in the absence of severe maternal injuries.
- In a pregnant Trauma patient, additional concern after the initial assessment and stabilisation of the “ABCD” is to pay attention to the uterine and placental injuries if any, monitoring of the foetus and as appropriate further treatment based.
- After the initial stabilisation, it is important to do a complete examination i.e. secondary survey, which should include additionally specific to pregnancy (This will also be addressed during primary survey if the need arises – e.g. During Circulation, if the Haemorrhage source is uterine trauma)
- Examination of uterus – look for rupture, tenderness, peritoneal irritation
- Placenta – as source for bleeding
- Pelvic examination for PV bleeding, premature rupture of membranes
- Foetal Monitoring – foetal activity
  - Simultaneously along with initial stabilisation, foetal assessment is must.

- Once initial stabilisation is done, the patient can be transferred to labour suite or ICU upon the condition and foetal continuous monitoring started.
- Multi-disciplinary approach is must for good outcomes
- “Best way to treat the foetus is to treat the mother. Pregnancy should not restrict any diagnostic, therapeutic or resuscitative measures deemed to be necessary in a trauma patient.”



## Initial Assessment:

- The principles of management of a trauma victim are:

### Airway

- Goals should be patency as well as protection as mentioned in above diagram.
- Airway oedema and difficult airway management can be expected
- Late trimester because of delayed gastric emptying as well as decreased tone of lower oesophageal sphincter – expect and be prepared for increased risk of aspiration

### Breathing

- Decreased FRC results in more rapid desaturation, appropriate oxygenation is must.
- In case of suspected chest injury needing ICD placement especially in third trimester, consider placing them higher since diaphragm and abdominal contents have cephalad misplacement physiologically.

## Circulation

- Blood volume increases significantly, and significant blood loss may occur before the hypotension appears.
- Fluid administration: first goal is to restore circulating blood volume.
- Blood and products administration should be ensured if blood loss exceeds 30% of blood volume, Blood laboratory investigations should be sent early and should include minimum of Complete blood count, Blood grouping, cross matching, and a Coagulation profile.
- Vasopressors as needed to maintain systemic perfusion. Even though concept of hypotensive resuscitation is followed in trauma till the definite damage control surgery takes place, the data is lacking in pregnant patients and should not be followed.
- Always use wedge under right hip to prevent aortocaval compression especially in late pregnancy.
- Nurse and examine in left lateral position to avoid supine hypotension.

## Disability

- Assess Neurological status and for the presence of any other major injury.
- Essential to consider Cervical spine fractures and appropriate immobilisation may be needed.

## Secondary assessment:

- It is important that mothers are looked for all abdominal, thoracic, neurologic as well as orthopaedic injuries in detail.
- Multidisciplinary consult wherever required is appropriate.
- Use necessary investigative modalities to reach a definitive diagnosis for both the mother and foetus.

## Maternal assessment:

- Physical examination from head to toe.
- Get relevant and essential x-rays done if facility available.
- Continually monitor vital signs.
- Continue primary management.
- Look for premature labour.
- Vaginal examination.
- If laparotomy is indicated, do not postpone because of pregnancy.

## Foetal assessment:

- Foetal survey as mentioned above is important.
- Auscultate for Foetal heart sounds.
- Bradycardia is a sign of Foetal distress.
- Assess gestational age by ultrasonography.

## Types of trauma during pregnancy:

- It is beyond the scope of this chapter to have detailed discussion on Trauma during pregnancy, however a brief overview is presented here.
- Three types of trauma can occur during pregnancy
  - Penetrating trauma.
  - Non-penetrating trauma (Blunt trauma).
  - Heat related trauma (Thermal trauma).

### Penetrating trauma:

- Penetrating violence against women could be:
  - Gunshot injury.
  - Sharp instrument injury (Knife, broken bottle).
  - In early pregnancy, the abdominal organs commonly injured are intestine, spleen and liver.
  - In late pregnancy due to an increase in the size of the uterus there are more chances of uterine injury, direct Foetal, placental membrane and umbilical cord injury.

### Evaluation and management:

- Thoracic/abdominal wound may need exploration.
- Radiological evaluation for any cavity penetration.
- Dye evaluation of wound can be done if no X-rays are available.
- If mother's condition is stable, evaluate Foetal wellbeing.
- If bloody amniotic fluid, suspect Foetal injury.
- Examine uterus for any penetrating injury during exploratory laparotomy.
- If injury present and Foetus > 25 weeks and there is evidence of Foetal compromise, deliver the baby by caesarean section.
- If Foetus < 25 weeks conservative management should be attempted. The role of tocolytics is controversial.

### Non-penetrating (Blunt trauma):

- The types of blunt trauma in pregnancy are similar to those in the non-pregnant state viz. retroperitoneal haemorrhage, fracture pelvis, placental separation and head injury. But the most common cause of maternal mortality is head injury
- Commonest causes of Foetal mortality are maternal shock or death and placental separation.

### Assessment:

- "Unless otherwise proven, assume a trauma patient to be hypovolemic, full stomach and having an injured cervical spine."
- Take a brief history to assess the type of injury and its severity
- Monitor vital signs.
- While examining or intubating always keep possibility of cervical spine injury in mind.

- Chest examination to rule out haemothorax, rib fracture, pneumothorax etc.
- Examine all the four limbs individually.
- Examine abdomen for bruising/pain/tenderness/rigidity which may suggest intra-abdominal organ injury or haemoperitoneum.
- Vaginal examination should be performed gently to look for blood, meconium, and amniotic fluid.

#### **Management:**

- Maintain airway and administer oxygen.
- Intravenous cannulation 16 G two lines for I.V. fluids and blood.
- Monitor vital signs.
- Obtain blood for laboratory investigations and cross-matching.
- Endotracheal intubation and mechanical ventilation if indicated.
- Urinary bladder catheterization to monitor urine output and to rule out bladder trauma.
- Nasogastric tube insertion for suction and to assess GI tract integrity.
- If Foetus > 24 weeks, Foetal monitoring is to be instituted. Foetal heart rate acceleration (increase of >15 bpm lasting for at least 15 seconds) is a good sign. Bradycardia and late deceleration are bad signs.
- During placement of i.v. cannula and establishment of monitoring take detailed history and do complete examination of mother and Foetus.
- USG: Radiological examination is not contra-indicated because the risk of undiagnosed trauma to mother is more dangerous than risk of irradiation to Foetus.
- If the gestational age of the Foetus is more than 24 weeks and is in distress but the general condition of the mother is stable, perform caesarean section.
- In case of suspected intra-abdominal trauma do peritoneal fluid aspiration.
- Exploratory laparotomy is to be performed if positive lavage, free air under diaphragm or abdominal distension is present.

#### **Thermal injury:**

- A pregnant woman may sustain flame burns, chemical burns or electrical burns.
- Burn injuries are described according to the percentage of body surface area involved and the depth of the skin destroyed.
- The rule of nines is used to estimate the surface area burnt. Electrical burns are typically more serious than indicated by a superficial inspection due to underlying tissue damage.

#### **Management:**

- The management of a pregnant woman with burns does not significantly differ from that of a non-pregnant woman. But the Foetus is an additional consideration, which should be kept in mind.
- The patient with a thermal injury to the respiratory tract may rapidly develop airway obstruction- give humidified high concentration oxygen.
- Consider the need for early intubation if there is altered sensorium, direct burns to face, hoarseness or stridor, soot in nostrils or sputum or dysphagia, all of which suggest smoke inhalation

- Establish I.V access and start fluid resuscitation. The estimated fluid replacement using crystalloid is about 4ml/kg/percent in the first 24-hours. Half of this is given in the first 8-hours and half over the next 16-hours.
- Patients with burns will require potent analgesia–give titrated intravenous opioid.
- Continued monitoring of vital signs, CVP and urine output are important.
- Blood sample is obtained for-Hb%, Electrolytes, glucose, renal function tests

### KEY LEARNING POINTS

- Even though clear data from Indian population is lacking, in Western setup, trauma lead as one of most common non obstetric cause of maternal mortality
- Traumatic head injury and Haemorrhagic shock are most common causes of death in these patients
- Seemingly minor trauma in pregnancy still possess a great danger to foetal survival
- The principles of management more or less, remain same as compared to standard advanced trauma life support principles in non-pregnant patient, barring few important changes related to anatomical and physiological consideration in pregnancy and simultaneously ensuring foetal wellbeing.

### CHECK YOUR PROGRESS

Q1. Write short note on Epidemiology and complications about Trauma in Pregnancy.

Q2. Write in detail about the Initial assessment, secondary survey management for pregnant patients who had trauma.





# Week 10 - Module

## Pharmacology I- Anesthesia



# 38

## Opioids and Non opioid Analgesia

### INTRODUCTION

- Adequate analgesia is an important component of any Anaesthesia.
- Labour pain is considered as one of the most significant pain experience and some form of analgesia is required.
- It is important to know the pharmacology of opioids as well as non-opioids analgesia especially in parturient where there may be concerns for placental transfer of drugs as well as potential for drugs being secreted through breastmilk and passing onto neonates during breastfeeding.

### LEARNING OBJECTIVE

- After going through this module, one should be able to describe the:

Learning Objective	Knowledge	Skills
<ul style="list-style-type: none"><li>• Opioids: Pharmacology including dosage, indications, side effects, contraindications and fetomaternal concerns</li></ul>	✓	<ul style="list-style-type: none"><li>• Observe, assist and prescribe analgesic medications to patients peri-operatively under supervision.</li><li>• Note the doses, indications.</li><li>• Note in the logbook.</li></ul>
<ul style="list-style-type: none"><li>• Non opioids : Pharmacology including dosage, indications, side effects, contraindications and fetomaternal concerns</li></ul>	✓	

### OPIOIDS

- Opioids are substances that will produce analgesia and sedation by acting on the opioid receptor.
- However, they also have side-effect tendency to cause
  - Respiratory depression
  - Constipation

- Nausea and vomiting
- Pruritus
- Euphoric effects.
- Opioids are drugs which have significant abuse potential also.
- Prescription (medicinal) opioids can be classified based on their action on the drug receptor or through a simple approach of natural, semisynthetic and synthetically derived compounds
  - Natural Compounds: Morphine, Codeine
  - Semi-synthetic compounds: Oxycodone, Buprenorphine
  - Synthetic compounds: Pethidine, Fentanyl, Pentazocine,
  - Tramadol: Tramadol has opioid like activity as well as other mechanism of action
- Opioids are available to be given through oral route, parenteral route, transdermal route also.
- Commonly used opioids have tendency to cross placenta and is many a times avoided till the delivery of baby.
- Though in recent studies it has been shown that Alfentanyl and Remifentanyl do not cause much significant change in APGAR scores of baby delivered, further studies are needed. This also cannot be extrapolated to other opioids.
- Opioids help suppress sympathetic response to laryngoscopy, intubation as well as to surgical stimuli especially in the preeclampsia patients. But this needs to be balanced against placental transfer of drug causing respiratory depression and lower APGAR scores in the baby. More often than not, opioids are withheld till the baby is delivered.
- In the routinely used clinical doses, the concern for transfer of drugs through breastmilk is debatable. This is also to be weighed against adequate pain relief which itself will help mother to encourage breast feeding vs the risk of opioid being withheld (especially if pain is not amenable to NSAIDs / other modalities which might also not allow mother to adequately breastfeed the baby)
- Multimodal analgesia is the best way to achieve adequate analgesia in a parturient (either normal vaginal delivery or to someone who is planned for LSCS for a perioperative analgesia)
- Opioids (most of them) require narcotic license to prescribe and this concern also needs to be addressed. Tramadol, Pentazocine and Buprenorphine however are commonly available without the narcotic prescription.
- Let's have a brief review of opioids drugs used.

### Morphine:

- Morphine is a controlled narcotic drug because it is addictive and can be abused.
- There is no problem of addiction in the acute phase when used for analgesia or anaesthesia.
- It can also be used for pre- medication and intra-operatively as an adjunct to anaesthesia to reduce the cardiovascular response to extra and excessive stimulation.

Morphine freely crosses the placenta and can affect the foetus more than the mother, so you should give it after the extraction/delivery of baby.

- **Dosage:**

- For postoperative analgesia the adult dose is about 10 mg, although this may vary and up to 20 mg may be required.
- The paediatric dose is 100 mcg/kg.
- Traditionally, it is given every 4 hours “to be safe” but may give very poor analgesia, which is unsafe. If sedation and respiratory rate are monitored, then it can be even as infusion.
- It is usually given either IV or IM in the peri-operative phase.

- **Side effects:**

- Morphine causes a reduced respiratory rate, some respiratory depression and even apnoea if given quickly in too large a dose. This means one must be careful with patients having respiratory disease.
- Postoperative monitoring must be thorough to be safe.
- Postoperative nausea and vomiting are also common and one must give an anti-emetic when one is using morphine.
- Anorexia and constipation also occur.
- Anaphylaxis is rare though histamine release is not uncommon so it is best avoided in those patients with asthma.
- The effect of morphine will be additive with other sedatives where one needs to be careful.
- Slow, deep respiration, deep sedation and pinpoint pupils characterize over dosage.
- This can be fatal due to the respiratory depression or to cardiovascular collapse and arrest. One will need to support the respiration and ventilation and an opiate antagonist if available (Naloxone is safer than Nalorphine. Note that the effect of naloxone is shorter than morphine and so respiratory depression may recur. Monitor the patient in a high dependency area).

## **Pethidine:**

- Pethidine is a pure opiate agonist like morphine (though is synthetic) and therefore many of its effects are the same. The differences between the two drugs are highlighted here.
  - Pethidine’s action and side effects are of shorter duration than morphine.
  - The analgesia is 10 times less intense although it is still very powerful.
  - It is given IM/IV/SC 50 to 100 mg for pre-medication.
  - The same dose is used for postoperative analgesia (children, 1 mg/kg), given 3 hourly.
  - Intra-operatively use 0.25 mg/kg boluses for effect. Oral dosage is 1 to 1.5 mg/kg every 3 hours.
  - It causes less smooth muscle spasm than morphine and so is often preferred in bowel anastomotic surgery.

## **Pentazocine:**

- Pentazocine is a mixed agonist-antagonist.
- There is a ceiling on its effects. This has advantages and disadvantages. While one cannot get the same intensity of analgesia with Pentazocine that will be available with morphine and

pethidine; BUT at the same time the same amount of respiratory depression is also not there adding a better safety profile in tis terms (this is not absolute and vigilance is still required).

- There is very little PONV.
- Higher doses of pentazocine elicit psychotomimetic and dysphoric effects.
- It can be given oral or IM/IV/SC. Once again, do not use it orally postoperatively.
- IM/IV: For postoperative analgesia -adult 15 to 30 mg single dose, can be given BD

### Fentanyl:

- A pethidine congener.
- 80-100 times more potent than morphine.
- Short duration of action 30-40 minutes.
- Exclusively used in anaesthesia in the dose of 0.5-2 µg/kg I.V. 50 to 100 microgram as bolus dose repeatedly every 2 to 4 hourly with watch on respiratory depression and other side effects.
- But can be used by other routes like transdermal/trans nasal/lollypops.
- Side effects:
  - Causes skeletal muscle rigidity if given fast I.V. wooden chest syndrome.
  - Histamine release
  - Potential to cause respiratory depression if used in larger doses.

### Tramadol:

- Recently introduced centrally acting analgesic.
- Relieves pain by opioid as well as additional mechanisms.
- 100 mg of Tramadol I.V. is equi-analgesic to 10 mg morphine. Dose used is 50 to 100mg IV or IM or orally 8 to 12 hourly.
- Good oral bioavailability.
- Duration of action 4-6 hours.
- Causes less respiratory depression, sedation, constipation and urinary retention.
- It has additional anti-shivering action making it useful drug for control of shivering.
- Side effects:
  - Dizziness, nausea, sleepiness, dry mouth.
  - Sweating.
  - Minimal haemodynamic effects.
  - Nausea and Vomiting
  - It is contraindicated in seizure patients

### Naloxone:

- Competitive antagonist on all types of opioid receptors.
- Use: For reversal of opioid induced respiratory depression.

- Dose and administration:
  - Adults: 0.4-0.8 mg every 2-3 minutes up to a maximum dose of 10 mg
  - Infants: 0.02-0.04 mg every 2-3 minutes.
- Reversal of opioids may be associated with sympathetic stimulation if pain becomes severe. Need to be watchful.

### NON-NARCOTIC ANALGESICS:

- NSAIDs are routinely used as part of multimodal analgesia for LSCS and for labouring patient.
- Because they do not cause dependence or respiratory depression NSAIDS can be useful post-operative analgesics with a relatively stable safety profile.
- They have several uses.
  - Used alone they are effective in mild to moderate pain.
  - They can be used if there is breakthrough to simple analgesia with paracetamol and/or codeine.
  - They can also be used regularly postoperatively.
  - They can be used after major surgery to reduce the amount of opiate required – i.e. opioid sparing action
- The main disadvantages are
  - Not as potent as the opioids (especially the newer potent analgesics)
  - May cause gastric erosions – avoid in patients with known peptic ulcer disease or known history of gastrointestinal bleed.
  - Tendency to induce bronchospasm in susceptible population
  - Rarely renal failure.
  - Occasionally anaphylaxis or allergic reactions may occur.
  - They have been implicated to cause premature ductal closure in foetus and one needs to be careful as to when is the drug being used in pregnancy stage.

### Diclofenac sodium:

- Antipyretic anti-inflammatory drug.
- Inhibits PG synthesis.
- Has short lasting anti-platelet action.
- Is available now as IM or IV injection also (newer IV-IM preparation of injection are separate preparations from the conventional preparations which were used only for IM). IV should be used as infusion in diluting fluid rather than as bolus.
- Dose: 50-75 mg deep I.M. BD / TDS or IV BD or TDS along with diluting fluid as infusion

### Ketorolac:

- A novel NSAID with potent analgesic and modest anti-inflammatory activity.
- Equals the efficacy of morphine.
- Inhibits PG synthesis.



- Dose: 15-30 mg I.M. every 8 to 12 hours.

### Acetaminophen (paracetamol)

- Paracetamol is commonly used analgesic and antipyretic.
- It can be used alone or in combination with opioids in management of postoperative pain.
- Nowadays, it is frequently used in postoperative pain in dose of 1gm/dose IV infusion to maximum of 4gm/day in adults or converted into oral preparation as soon as feasible.
- Its weak analgesic in itself but well suits for treatment of mild pain as well as a adjuvant along with other analgesics decreasing their requirement.
- May cause acute hepatic dysfunction in certain patients though rare in commonly used dosages.

### KEY LEARNING POINTS:

- Adequate knowledge of opioids as well as non-opioids analgesics is very important for ensuring a adequate perioperative analgesia or analgesia for a labouring patient.
- Though Opioids are potent analgesics as well as help decrease the sympathetic response to laryngoscopy and intubation in patient undergoing GA, placental transfer of commonly used opioid analgesic remains a real concern related to respiratory depression and lower APGAR scores in new-borns. Therefore, more often than not, they are used after the baby is delivered.
- They also have other side-effects like nausea – vomiting, pruritus and constipation though can be used with appropriate care and watchful use. Whenever opioids are being used, respiratory depression in the patient must always be looked out for with adequate facility available for treatment of the same. Some of the commonly used and available opioids are fentanyl, Pentazocine, Tramadol.
- NSAIDs forms an important component of multimodal analgesia for labouring patients or patients requiring peri-operative analgesia. GI bleed because of peptic erosion, rare chances of inducing renal failure are some of the concerns that one needs to be watchful. They are not as potent as opioids but have opioid sparing action and are effective in themselves in reducing mild to moderate amount of pain.

### CHECK YOUR PROGRESS

Q1. What are the advantages and disadvantages of opioids?

Q2. Write short note on pharmacology of fentanyl, Pentazocine and Tramadol.

Q3. NSAIDs and Acetaminophen. Write short note on their uses in Anaesthesia and postoperative setup with few examples of drugs and their doses.

# 39

## Intravenous Anesthesia Induction Agents

### INTRODUCTION

- Induction agents are drugs, which induce anaesthesia i.e., when given in an appropriate dose will produce unconsciousness (mostly in one arm brain circulation time).
- They can be used as sole anaesthesia agent for induction, maintenance or can be combined with other drugs. They form important armamentarium.
- Here we will look at only commonly used three agents; Thiopentone (this causes a generalised depression of the CNS), ketamine (this causes a dissociative anaesthesia) and propofol.
- All of these drugs have unique advantages as well as side effects and needs to be studied appropriately to decide which drug to be used in which condition.

### LEARNING OBJECTIVE

- After going through this module, one should be able to describe the:

Learning Objective	Knowledge	Skills
<ul style="list-style-type: none"><li>• IV induction agents (General drug information, its preparation, Doses and administration, Indications and contraindications)</li></ul>	✓	✓ <ul style="list-style-type: none"><li>• During the posting observe, assist and then practice under supervision the use of appropriate IV induction agents.</li><li>• Document their use in clinical logbook at appropriate place.</li></ul>

### THIOPENTONE: ULTRASHORT ACTING BARBITURATE:

#### Physical properties / Presentation

- Yellow-powder, stored in nitrogen.
- Reconstituted with distilled water/normal saline to a 2.5% solution (5% solution was used but causes greater problems with extravasation). The solution is strongly alkaline and irritant. Once constituted, it should be used within same session.
- Available as multidose vials and 500 mg and 1-gram vial.

### Pharmacokinetics:

- The initial blood concentration is high, causing high brain concentrations.
- The drug is then distributed around the body; the brain concentration decreases, and the patient wakes up.
- Wake up is after approximately 3 to 6 minutes. It is metabolised and then excreted by the kidneys.

### Pharmacodynamics

- Depression of the cardiovascular system -reduced contractility and vasodilatation
- Respiratory depression, which is increased with use of opiates.
- Minimal muscle relaxation
- Little effect on the uterine tone. Crosses the placental barrier and will sedate the foetus.

### Dosage and administration:

- Dose of 3-5mg/kg. However, the very young require 7mg/kg. The dose for rapid-sequence induction is 5mg/kg. This is based on the lean body mass.
- Dosage requirements are reduced in the elderly, hypovolemic, sick and premedicated patients.
- Usually 5mg/kg is given by slow intravenous injection, titrating the dose against the effect. Further drug is given as required.
- Loss of the eyelash reflex shows anaesthesia. Anaesthesia occurs in less than 30 seconds after an adequate dose has been given - except in patients who have a prolonged circulation time (elderly, shocked, fixed cardiac output states), then give the drug VERY slowly.

### Advantages:

- Smooth induction

### Disadvantages:

- No analgesic action.
- Repeated doses cause prolonged effect.
- Cardiac depression: this is particularly marked in the elderly, sick and shocked patients.
- Respiratory depression usually causes a short period of apnoea.
- Tissue necrosis and intra-arterial injection.
- Occasionally laryngospasm and bronchospasm because the laryngeal reflexes are not fully depressed.
- Allergic reactions and thrombophlebitis are rare.

### Clinical indications and uses:

- Induction of anaesthesia
- Combined with ketamine as IVA (Intravenous anaesthesia)
- Maintenance of anaesthesia: 2-3ml boluses can be used, however dosages of 10mg/kg will cause markedly prolonged recovery time.

### **Contraindications:**

- Absolute: Acute Intermittent porphyria.
- Relative: Airway obstruction, reactive airway diseases, Hypovolemic shock.

### **Precautions:**

- Cardiovascular disease.
- Should not be mixed with any other drug
- Severe liver and kidney disease.

### **Drug interactions:**

- Other sedative agents will cause additive sedation. A thick precipitate is produced if Thiopentone is mixed with Suxamethonium.

## **KETAMINE:**

### **Physical properties & Presentation**

- Phencyclidine derivative
- Presented as a clear solution.
- Ketamine 10mg/ml and 50 mg/ml vials. It also comes as 50 mg/ml- 2 ml amp, which are preservative free.
- Store in the fridge once the vial has been opened.

### **Pharmacokinetics:**

- Peak levels, after IM injection occurs at 20 minutes.
- Metabolised by the liver and excreted by the kidneys.

### **Pharmacodynamics:**

- Stimulation of the cardiovascular system. Rise in Systemic vascular resistance and pulmonary vascular resistance.
- Respiration is well maintained, though apnoea will occur after rapid IV injection. The airway reflexes are relatively well maintained.
- Little effect on the uterine tone. Crosses the placental barrier and will sedate the foetus.
- Causes Dissociative anesthesia

### **Dosage and administration:**

- Intravenous induction with 1-2mg/kg by slow IV injection.
- Intramuscular induction with 8-10 mg/kg.
- Maintenance of anaesthesia- 0.5 mg/kg boluses as incremental dose.
- Analgesia: 0.25 to 0.5 mg/kg.

### Advantages:

- Prolonged action as a single agent with relative preservation of the airway reflexes.
- Maintenance of the blood pressure in shocked patients.
- Powerful analgesic.

### Disadvantages:

- Emergence delirium (though rare in children).
- There is no muscle relaxation and may in fact produce muscle rigidity.
- Prolonged recovery.
- Salivation (atropine required in children +/-adults also).

### Indications/use:

- Induction of anaesthesia – especially in patients who have acute shock, paediatric patients
- Maintenance of anaesthesia & analgesia. (Dose dependent)
- Ketamine is a potent analgesic. When used in analgesia for short term procedures with other anaesthesia agents, it gives excellent results.
- Since it really does not cause much respiratory depression in most of the patients, it is supposed to be a safe agent when used correctly.

### Contraindications:

- Raised intracranial
- Raised intraocular pressure.
- Patients having arrhythmogenicity or uncontrolled hypertension or severe pulmonary hypertension.

### PROPOFOL:

- 2,6 di-isopropyl phenol
- First use reported in 1977.
- Presented as 1% formulation in oil and water emulsion containing 10% soyabean oil, 1.2% egg phosphatide and 2.25% glycerol.
- Induction dose: 1-2.5 mg/kg – I.V.
- Resistance to the anaesthetic effects of propofol is occasionally encountered, those patients may require 50% increase in dosage.

### Pharmacokinetics:

- Rapid distribution and elimination as glucuronide with mainly renal excretion.

### Pharmacodynamics:

- Dose related surgical anaesthesia.
- Dose related respiratory depression.

- Even though some epileptiform activity is seen, it has Anti-convulsant action.
- **CVS:**
  - Causes arterial hypotension so should be administered slowly.
  - Can be prevented by vascular volume loading or by head down tilt. To be used with caution in hypovolemic patients.
  - Decrease in SVR

### **Dose and administration:**

- Induction dose: 1-2.5 mg/kg – I.V.
- Propofol is the most commonly used drug for total intravenous anesthesia where it is used as continuous infusion.
- Pain on injections, more so in small peripheral veins can be reduced by
  - Mixing with local analgesics.
  - Administration into a large vein.
  - Cooling the drug.
- Loss of verbal response indicates best response to Propofol induction

### **Advantages:**

- Easily available and easy to use
- It abolishes airway reflexes and thus is an ideal agent for inserting supraglottic airway devices
- It has antiemetic action in low dose also.

### **Disadvantage:**

- Pain on injections (can be dealt as above)
- Causes hypotension
- Rarely anaphylaxis occurs to Propofol
- Propofol infusion syndrome when given for extended duration of infusion, especially in children.

### **Indication:**

- Sole IV Induction agent
- Can be used for TIVA or as intermittent boluses for short procedures

### **Contraindications:**

- Patient in shock
- Known allergic reaction in the past

### **KEY LEARNING POINTS:**

- IV induction agents are very commonly used drugs in Anaesthesia

- Thiopentone, Propofol and Ketamine are commonly used drugs for the same. It is imperative that Anaesthesiologists are familiar with their use.
- Thiopentone, a short acting barbiturate has smooth induction. But it preserves the airway reflexes and therefore not ideal for use in patients planned for SGD. Also, it causes hypotension and therefore not used in patients with shock. It has no analgesic property of its own.
- Propofol has gained popularity over last decade and has smooth induction. It abolishes airway reflexes and therefore is well suited for patients planned for Supraglottic Devices insertion. It causes apnoea. It causes hypotension mainly due to vasodilatation and therefore can't be used in the shock.
- Ketamine a phencyclidine derivative causes sympathetic stimulation raising blood pressure and therefore is agent of choice for induction in acute shock states. It has dose dependent Analgesia (excellent analgesia) and Anaesthesia properties. In the doses routinely used, it generally does not cause apnoea and is therefore safer drug even in relatively inexperienced hand. However, the raise in intracerebral pressure, intraocular pressure, sympathetic stimulation causing tachycardia and hypertension makes them less than ideal in all scenarios. It has tendency to cause hallucinations which can be decreased with benzodiazepine premedication wherever appropriate.

## CHECK YOUR PROGRESS

Q1. Induction agent of choice in patient with acute shock with PPH with a blood pressure of 80/50 is

- Propofol low dose
- Ketamine
- Thiopentone in titrated doses
- Any of the above can be used safely as per availability

Q2. Which of the following agent is not suitable alone to insert SGD

- Ketamine
- Propofol
- Thiopentone
- All agents can be used without any issues for SGD insertion

Q3. Write short notes on

- Thiopentone
- Propofol
- Ketamine



# 40

## Inhalational anesthesia agents

---

### INHALATIONAL ANAESTHETIC AGENTS:

- The ancient tradition of inhalation of fumes and vapours for intoxication forms the basis of administering anaesthetic agents by pulmonary route.
- Ether and chloroform were the initial agents and as time progressed with the advent of newer much safer inhalational agents came into practice. Now a brief review of pharmacokinetics of inhalational agents – Halothane, Isoflurane (Iso) and Sevoflurane (sevo) along with Nitrous oxide is being discussed, before going to respective agent.

### PHARMACOLOGIC PRINCIPLES:

- The safe administration of inhalational anaesthetic agents requires a good understanding of their pharmacokinetics.
- These agents exert their anaesthetic effect in a way which is not fully understood, but the depth of anaesthesia is directly proportional to the tension (or partial pressure) of the agent in the brain or arterial blood.
- Similarly, speed of induction and recovery are related to rate of rise and fall of arterial/brain tensions.
- Dalton's Law of partial pressures states that the pressure exerted by a mixture of ideal gases is the sum of the pressures exerted by the individual gases occupying the same volume alone. In clinical practice we are using gases at a pressure of ONE atmosphere (760 mm Hg). We will be referring to the partial pressure (tension) of anaesthetic gases in the unit of percentage (%) i.e. 760 mm Hg of 100%.
- The following factors affect the tension of anaesthetic vapor in brain and in arterial blood:

### Alveolar ventilation:

- Concentration (or tension of the agent in the inspired gas mixture).
- Transfer of vapour from alveoli to blood in the lungs.
- Transfer of vapour from arterial blood to body tissues.
- We, as an anaesthetist can change only the first two factors. But, in the clinical practice we will alter only the second i.e. concentration and this will be guided by MAC.

### What is MAC?

- MAC is the minimum alveolar concentration of anaesthetic agent (at one atmosphere ambient

pressure) that produces immobility in 50% of those patients or animals exposed to a noxious stimulus so it is a measure of anaesthetic potency.

- There are limitations to its clinical use because
  - By definition, 50% of patients move in response to incision.
  - The concept of MAC is applicable to only non-paralysed patient.
  - So, a lower concentration than MAC may safely be used to prevent awareness, particularly when anaesthesia is supplemented with nitrous oxide, opioids or other CNS depressants.

Other related terms:

- MAC Awake.
- MAC BAR.
- Full term pregnancy is associated with reduced anaesthetic requirement, i.e. by 25% for halothane and 40% for isoflurane.

We will have brief review of Nitrous Oxide, Halothane, Isoflurane and Sevoflurane.

## Nitrous oxide:

Physical properties:

- Colourless, slightly sweet smelling, non-irritant.
- Stable in the presence of soda lime.
- Neither flammable nor explosive, but it will support combustion "Even in the absence of Oxygen".
- As it is stored in a liquid form, pressure gauge is not an indicator of amount of content.
- Impurities: During production, ammonia, nitric oxide, nitrogen, nitrogen dioxide and carbon monoxide are produced.

Entonox:

- Mixtures of equal volumes of N<sub>2</sub>O and O<sub>2</sub> remain gaseous under pressure and release a gas of constant composition.
- Below - 8°C the contents separate into liquid N<sub>2</sub>O and gaseous O<sub>2</sub>.
- Danger: Initially that will give high O<sub>2</sub>% and later high N<sub>2</sub>O% (almost 100%) so may lead to hypoxia.

Absorption and fate in the body:

- Nitrogen dioxide in concentration greater than 50 ppm causes laryngospasm, reflex inhibition of breathing and pulmonary oedema.
- Nitrous oxide is readily absorbed in the body.
- 100 ml plasma will carry 45 ml N<sub>2</sub>O.
- The gas being very soluble, the uptake and elimination are very fast. So, there is risk of hypoxia at the time of recovery from anaesthesia – diffusion hypoxia (Fink 1955).

## Systemic Effects of N<sub>2</sub>O

- **CNS:**
  - Weak anaesthetic with a MAC of 104.
  - Powerful analgesic in sub anaesthetic doses.
  - Acts primarily by directly depressing spinal transmission of impulses and activation of inhibitory supraspinal systems.
- **CVS:**
  - Direct myocardial depressant.
  - Due to action on the suprapontine areas of brain it has a sympathomimetic effect.
  - Net result – No cardiovascular depression so safe in cardiac patients.
- **Respiratory System:**
  - Decreases tidal volume and increases respiratory rate and minute volume.
  - During recovery – rapid outpouring – hypoxia.
- **GIT:**
  - Causes nausea and vomiting
  - Peripheral effect – causes distension of gut so avoid IPPV with facemask with N<sub>2</sub>O.
  - Central – interacts with endogenous opioid system.

### Toxic effects:

- More than 6 hours of anaesthetic exposure to N<sub>2</sub>O causes almost total inactivation of methylcobalamin (Vit B<sub>12</sub>).
- Bone marrow depression.
- During LSCS the duration of exposure to N<sub>2</sub>O is rarely more than 2 hours so no cause for concern.

## INHALATIONAL VOLATILE AGENTS (HALOTHANE, ISOFLURANE AND SEVOFLURANE)

- Inhalational agents have a continuation of spectrum action ranging from sedation to General Anaesthesia, which is dose dependent.
- MAC values of Inhalational agents when added with other agents (Like IV or inhalational) becomes either additive or synergistic, decreasing the MAC value for individual agent.
- Pregnancy decreases the MAC
- With increasing age, the MAC value decreases.
- 

Table 1: Clinical effects & comparison of inhalational agents (Halothane, Isoflurane, Sevoflurane)

Organ system	Clinical effect	Comparison potency
Muscular System		
Skeletal Muscles	Relaxes skeletal muscles	Sevo > Iso > Halothane
Smooth muscles	Relaxes smooth muscles (Bronchial, uterine)	

Organ system	Clinical effect	Comparison potency
Cardiovascular system		
Heart	All inhalational agents in different proportions and at different doses produces myocardial depression related hypotension and decreased cardiac output	
Vasodilatation	Inhalational agents cause Vasodilatation also.	Isoflurane and Sevoflurane have vasodilatory action.
		Halothane however maintains SVR and produces decreased BP by decreasing Cardiac output.
Respiratory System		
Airway reflexes	Irritation, coughing and at times may lead to laryngospasm especially during induction	This is more prominent with strong odour agents like Isoflurane than others. Sevoflurane is the most favourable amongst the agents
Bronchial tree effects	Bronchodilators because of beta2 stimulation	Sevoflurane has most potent broncho dilatory effects. This makes them useful in airway reactive diseased patients.
Ventilatory drive	In Anaesthesia planes related doses, the inhalational agents progressively cause respiratory drive depression.	
Postoperative Nausea and Vomiting (PONV)		
PONV	All of them increase the risk of PONV.	All of them. (Nitrous oxide has more potency)

- Inhalational agents can be used for induction as well as maintenance with careful monitored use.

### Halothane:

- Physical properties / Presentation:
- Introduced into clinical practice in 1956.
- Colourless sweet-smelling volatile liquid.
- Decomposed by light therefore stored in a brown bottle.
- A preservative, Thymol is added to prevent decomposition of the Halothane which can cause metal components to erode. However Thymol is not volatile and stays in the vaporizer, causing it to stick / clog.
- Blood/gas solubility is low (2.5).

### Pharmacokinetics:

- About 20% is metabolised in the liver. Some metabolites may cause liver toxicity due to either direct effect or hypersensitivity.

### Pharmacodynamics:

#### Cardiovascular System:

- Halothane depresses the heart in a dose related fashion resulting in a reduced cardiac output, the blood pressure and heart rate. The SVR is minimally reduced. This reduces the oxygen requirement of the heart.
- Arrhythmias are common. These are made worse with hypercapnoea, hypoxia and adrenaline. Therefore, only use LA solutions containing 1:160,000 or less adrenaline (corresponding to 6.25 mcg/ml)

#### Respiratory System:

- Halothane is non-irritant, nice to breathe.
- There is respiratory depression; increased rate and reduced tidal volume causing a rise in PaCO<sub>2</sub> in a spontaneously breathing patient.
- Halothane also reduces secretions, the pharyngeal/laryngeal reflexes and bronchospasm.

#### Uterus:

- Halothane relaxes the uterus and may cause post-partum haemorrhage during GA for LSCS; this does not occur at 0.5% - however, one must keep the mother asleep.

### Dosage and administration:

- The MAC value is 0.75.
- It takes 30 minutes for the partial pressure in the lungs to reach half of the partial pressure of the inspired gas. Therefore, the gas is given at 2-3 times this level to achieve anaesthetic levels more rapidly ("overpressure"), before being turned to a lower level.
- Anaesthesia is maintained with doses between 0.5 and 1.5%.

### Advantages:

- Rapid, smooth induction, minimal stimulation of secretions.
- It also produces bronchodilatation and some muscle relaxation.
- Relatively rapid recovery from anaesthesia.
- It is non-flammable.

### Disadvantages:

- Poor analgesia.
- Arrhythmias are common, especially with the use of adrenaline.
- Postoperative shivering
- With concern of Hepatotoxicity and advent of safer newer inhalational agents, it is slowly being phased out from the clinical Anaesthesia practice.

### Contraindications:

- Known hypersensitivity, malignant hyperthermia.

### Precautions:

- Patients on beta-blockers, concurrent liver disease and arrhythmias.
- Ideally, patients should not have two halothane anaesthetics within 3-6 months, because of the risk of hepatotoxicity.

### Drug interactions:

- $\beta$ -blockers and other hypotensive agents. Adrenaline.

### Isoflurane:

- Introduced in clinical practice in 1983.
- Colourless, with slightly pungent smell.

### Advantages:

- Cost-effective
- Does not sensitise myocardium to catecholamines.
- Blood/Gas partition coefficient=1.4, MAC=1.15.
- Less myocardial depressant as compared to halothane.

### Disadvantages:

- Decreases BP by decreasing SVR. Has tachycardia property which at times may be undesirable in patients like ischemic heart disease.
- Induction is rapid but not smooth because of irritant nature, its pungent smell limits its use as inhalational agent for induction.
- Has good fat solubility and therefore at times results in prolonged time for emergence from Anaesthesia.
- Relaxes pregnant uterus also.
- Up to concentration of 0.75% suitable for LSCS.

### Sevoflurane:

- It is a sweet smelling and less irritating agent and therefore is a good choice for inhalational induction of Anaesthesia, if planned. Its pharmacokinetic properties make it a agent which has rapid uptake because of the Blood gas partition. Coefficient = 0.69. Very rapid induction and recovery - switch on and switch off anaesthesia
- MAC is 2%.
- Does not sensitize myocardium and has very less negative chronotropic or inotropic effects

### Disadvantages:

- Costly as compared to other inhalational agents
- Theoretical risk of Compound A formation in closed circuit with CO<sub>2</sub> absorber and renal toxicity at very low flow Anaesthesia

### KEY LEARNING POINTS:

- Inhalational agents have dose dependent effects from sedation to General Anaesthesia.
- Halothane because of its hepatotoxicity concerns is slowly being taken off from market and less used as compared to other safer inhalational agents.
- Anaesthesiologist should be familiar with the effects of the inhalational agents on various organs system and their clinical implications. Though not absolute, an oversimplification can be stated as
  - RS: Bronchodilator, and dose dependent respiratory depression
  - CVS: Hypotension (Myocardial depression and / or vasodilatation)
  - Airway reflexes: Coughing, laryngospasm (least with Sevoflurane)
  - Smooth muscles: Bronchial and Uterine muscles
- Increasing inhalational agents more than 1 MAC is seldom required especially in maintenance phase and should be done with concern.

### CHECK YOUR PROGRESS:

1. MAC is defined as \_\_\_\_\_
2. Values of MAC for
  - Halothane:
  - Isoflurane:
  - Sevoflurane:
3. Nitrous oxide, second gas effect and diffusion hypoxia: Write a short note
4. Write down the effects of inhalational agents on various body organ system. Compare Isoflurane, Halothane and Sevoflurane.
5. Write short note on Hepatotoxicity and Halothane.
6. Write short note on Nephrotoxicity concern and Sevoflurane



# 41

## Neuromuscular Blocking & Reagents

### INTRODUCTION

- Neuromuscular blocking drugs (NMB) are most commonly used by Anaesthesiologists in perioperative setup or in the intensive care unit
- NMB drugs are used to
  - Facilitate intubation
  - Help relax skeletal muscle for providing adequate surgical field and immobility in complex surgeries
  - In Intensive care unit especially in severe ventilator failure cases by facilitating ventilation, helping to tolerate prone position ventilation.
- Broadly they can be classified as
  - Depolarising muscle relaxant- Succinylcholine acts as acetylcholine receptor agonist
  - Non-depolarising muscle relaxants viz. Pancuronium, Vecuronium, Atracurium, Rocuronium function as competitive antagonists.

### LEARNING OBJECTIVE

- After going through this module, One should be able to describe the:

Learning Objective	Knowledge	Skills
• NMB drugs (General drug information, its preparation, Doses and administration, Indications and contraindications)	✓	✓ <ul style="list-style-type: none"><li>• During the posting observe , assist and then practice under supervision the use of appropriate NMB agents.</li></ul>
• Difference between depolarising and non-depolarising agent		<ul style="list-style-type: none"><li>• Learn the use of Depolarising and non-depolarising use in same cases</li></ul>
• Reversal of Non depolarising muscle relaxants		<ul style="list-style-type: none"><li>• Learn the reversal drug Neostigmine administration in OT under supervision.</li><li>• Document their use in clinical logbook at appropriate place.</li></ul>

## Suxamethonium:

- This is a short acting depolarising neuromuscular blocking agent.
- This is available as a 2 ml ampoule or as a 10 ml multidose vial.
- It is a clear solution, which has a strength of 50 mg/ml. It should be kept refrigerated.

### Pharmacodynamics:

- Succinylcholine is structurally two Ach molecules which are bound together
- It acts on the Nicotinic receptor of Neuromuscular junction and causes membrane depolarisation ultimately resulting in the muscle contraction and then followed by a paralysis
- It has no direct effect on smooth or cardiac muscle contraction

### Pharmacokinetics:

- Suxamethonium is unique in that, it is metabolised by butyryl-cholinesterase (also known as plasma cholinesterase) and is rapidly metabolised resulting in shorter duration of action.
- Suxamethonium acts as non-competitive type of drug.

### Dosage and administration:

- It is given in a dose of 1-2 mg/kg. If there is no intravenous access it can also be given sublingually (1-3mg/kg) and intramuscularly (4-5 mg/kg).

### Advantages:

- It gives intense neuromuscular blockade creating excellent intubating conditions within 30–60 sec. and which last only for a short period of time.
- Thus if there is a problem in intubating, spontaneous breathing starts within a short time < 5 min and oxygenation can be maintained with adequate ventilation.

### Caution:

- The administration of Suxamethonium has certain complications:
  - Hyperkalaemia: Rises of up to 0.5 mmol/l especially in neuromuscular problems or burns- should be avoided for the first 6 months to up to a year after burns. It should also be avoided in paraplegic patients and muscle dystrophy patients.
  - Cardiovascular: can precipitate a severe bradycardia and asystole specially in children and usually after a second dose.
  - Muscle pains: Usually in young male adults specifically after fasciculations.
  - Pseudocholinesterase deficiency: there are several types of this inherited condition, which cause a prolonged action of the drug.
  - Raised intraocular and intracranial pressure: as a result should be used with caution in cases of raised intracranial pressure and open eye injuries.
  - Anaphylaxis Suxamethonium is implicated in significant amount of anaphylaxis occurring because of neuromuscular blocking agents.
  - Malignant Hyperthermia

### Indication:

- Rapid sequence intubation
- Short intense neuromuscular paralysis as for facilitating endotracheal intubation as it acts within 30-60 sec. and lasts for only 3-5 min. After Scholine, especially in longer duration surgeries, it is then followed by giving competitive antagonist NMB drug further to keep skeletal muscles paralysed.
- It can also be used to break a laryngospasm.
- Other short procedures where a short acting paralysis would be good enough for the procedure planned (e.g. Modified electroconvulsive therapy)

### Contraindications

- Hyperkalaemia, Burns, Muscular dystrophy, paraplegic patients, and Susceptible patients to malignant hyperthermia
- Relatively contraindicated in patients mentioned in above section of disadvantages.

### Non depolarising Agents:

- They function as competitive antagonists of Acetylcholine at the nicotinic receptors located in the post synaptic region of the neuromuscular junction.
- They bind to the receptors and 'compete' with Ach for binding at the receptors. Once 70 to 80% of receptors are blocked, neuromuscular blockade starts becoming evident clinically. A complete block is said to be produced when more than 90% of the receptors are blocked.
- They are classified into two groups
  - Benzyl-isoquinolinium compounds
    - E.g. Atracurium, Cisatracurium
  - Amino steroid compounds
    - Vecuronium, Rocuronium
- We will look at the important and commonly used agents in following section.

### Important considerations:

What medical illnesses predispose a patient to delayed awakening or a prolonged neuromuscular block?

- Liver and renal disease both cause a delay in the metabolism and excretion of muscle relaxants and in such conditions the dose of such drugs should be reduced.
- Uraemia affects awakening.
- Hypoglycaemia and ketoacidosis both cause a depressed level of consciousness and may thereby delay wakening.
- Severe hypothyroidism has the same effects.

Which drugs increase the effects of non-depolarising neuromuscular relaxants?

- Antibiotics especially aminoglycosides.
- Antihypertensive – Nitroglycerine.

- Inhalation anaesthetics- Halothane > Enflurane > Isoflurane.
- Local anaesthetics.
- Lithium.
- Magnesium sulphate.

### What other pharmacologic variables affect blockade?

Neuromuscular blockade is prolonged by:

- Hypothermia.
- Respiratory acidosis.
- Hypokalaemia and hypocalcaemia.
- Hypermagnesemia - as in eclamptic patients.

### Vecuronium:

- This is an intermediate acting non-depolarising neuromuscular agent.
- Each vial consists of a white crystalline powder, which contains 4 mg of Vecuronium. When reconstituted with 4 ml of sterile water it makes each ml contain 1 mg of the drug.
- It should be stored in a refrigerator but not frozen.

### Advantages:

- Its onset of action is within 3-5 min and lasts only for 20–30 min. As a result it can be used in shorter procedures.
- It does not cause an increase in the heart rate or blood pressure and thus is a safer drug in cardiac disease patients.

### Caution:

- It should be used with caution in hepatic or renal disease.

### Dosage and administration:

- For intubation it is given at a dose of a 100 mcg/kg which would be about 5 mg in a 50 kg patient.
- For maintenance it is given as a bolus of 40-80 mcg/kg followed by top-ups by boluses of a fourth of the initial bolus.

### Rocuronium:

- This is a steroid analogue of vecuronium and is designed to provide rapid onset of action.
- Its fast onset of action in 60 to 90 seconds to provide intubating conditions makes it as one of the contenders to facilitate intubations ( Modified Rapid sequence intubation )

### Advantages over Succinylcholine:

- Due to its rapid onset of action it can be used instead of succinylcholine in those patients where succinylcholine is to be avoided.

- This is particularly in patients with raised potassium or those with rhythm disturbances.
- To achieve ideal intubation conditions within 90 sec., it should be administered at a dose of 1 mg/kg.

#### Caution:

- It may be suitable for rapid sequence inductions but in contrast to succinylcholine, it has a much longer duration of action, which still makes it unsuitable if the intubation is anticipated to be difficult (One should be careful in using this as direct agent for intubation especially if one is not expertise in intubation (where muscle relaxant for intubation itself as a whole might be a problematic approach) and / or if there is anticipated difficult intubation as noticed in pre-Anaesthesia check-up.
- It also has slightly greater Vagolytic (Decrease in Heart rate) tendencies than Vecuronium.

#### Atracurium:

- Atracurium Besylate is relatively a new skeletal muscle relaxant.
- Its elimination is not affected by renal or hepatic derangements. The drug is eliminated from the body through Hoffman's degradation. This makes it very suitable in these kind of patients.
- It causes histamine release, is contraindicated in patients known to have hypersensitivity reactions.
- It's neuromuscular blocking action is enhanced by Halothane, Isoflurane and Enflurane

#### Dosage and Administration:

- An initial dose of 0.4 to 0.5 mg/kg generally produces maximum neuromuscular block within 3 to 5 minutes of injection, with good or excellent intubation conditions within 2 to 2.5 minutes in most patients.
- The duration of neuromuscular block produced by it is approximately 15-20 minutes.
- Recovery from neuromuscular block can be expected to begin approximately 20 to 35 minutes after injection.
- Repeated administration of maintenance doses of it has no cumulative effect.
- It is available as 2.5 ml ampoules containing 10 mg/ml.
- It should be stored in refrigerator.

#### Cholinesterase Inhibitors:

- These drugs also known as anticholinesterases are used to reverse the neuromuscular blockade of non-depolarising relaxants.
- Non-depolarising relaxants compete with acetylcholine to bind to nicotinic cholinergic receptors.
- The anticholinesterases indirectly increase the amount of acetylcholine available to compete with the non-depolarising agent thereby re-establishing neuromuscular transmission by inhibiting the action of acetylcholinesterase enzyme which breaks Ach, thereby raising its concentration. (That's why the name cholinesterase inhibitor)
- What are their effects on various organ systems?

- As a result, the effects of these drugs on muscarinic receptors the effects on various systems are as follows:
  - Cardiovascular : Bradycardia, Dysrhythmia.
  - Pulmonary : Bronchospasm, Increased secretions.
  - Cerebral : Excitation.
  - Gastrointestinal : Intestinal spasm, increased salivation.
  - Genitourinary : Increased bladder tone.
  - Ophthalmologic : Pupillary constriction.
- The most commonly used agent is neostigmine though there are others like pyridostigmine, physostigmine and recently available "Suggamadex"

### Neostigmine:

- To reverse muscular blockade it should be given when the patient is making efforts to breathe.
- Ideally the use of Neuromuscular blocking agents as well as use of the cholinesterase inhibitors should be governed by the clinical monitoring as well as objective monitoring of nerve-muscle physiology i.e. neuromuscular monitoring utilising the TOF ratio, Double burst stimulation. However in case of non-availability of the above, clinical monitoring alone should be used carefully

### Dosage and administration:

- It is available as vials of 1 ml containing 0.5 mg of the drug or 5 ml containing 2.5 mg of the drug.
- It is given in the dose of 0.04- 0.07 mg/kg and takes about 3-4 min to take effect.
- Muscarinic side effects are minimised by concomitant administration of an anticholinergic agent Glycopyrrolate 0.2 mg per 1 mg of neostigmine. If in rare instances glycopyrrolate is not available, then Atropine 0.4 mg per 1 mg of neostigmine may be considered watching for the side-effects.
- Neostigmine crosses the placenta and causes foetal bradycardia.
- Nowadays premixed preparation of Neostigmine with Glycopyrrolate is commonly available containing 2.5 mg of Neostigmine and 0.5 mg of Glycopyrrolate in the form of ampoules for use.

### KEY LEARNING POINTS:

- Anaesthesiologists should have a thorough understanding of the Neuromuscular blocking agents. They are of immense clinical benefit to Anaesthesia practice when used appropriately.
- Succinylcholine is a depolarising agent and produced intubating condition within 60 to 90 seconds facilitating the rapid sequence intubation. Its short duration of action of 5 to 10 minutes makes it a very favourable drug. Hyperkalaemia, Bradycardia, Malignant hyperthermia in susceptible patients should be looked out and contraindications of the drug should be carefully observed.
- Atracurium, Vecuronium and Rocuronium are commonly used non depolarising agents and have longer duration of action as compared to Suxamethonium. Other than helping to facilitate intubation, they can be used to maintain skeletal muscle relaxation throughout the

surgical phase. Individual drug considerations in terms of advantages, cautions and therefore indications and contraindications should be well understood.

- Neostigmine, the cholinesterase inhibitor is used to reverse the neuro-muscular blockade caused by non-depolarising agents. It is used along with anticholinergic agent like glycopyrrolate/atropine to avoid the side effects associated with the use of drug neostigmine.

### **CHECK YOUR PROGRESS:**

Q1. Classify the Neuromuscular blocking agents with examples.

Q2. Write short note on succinylcholine.

Q3. Classify non depolarising agents and write short note on Atracurium.

Q4. Write a short note on neostigmine.



# 42

## Local anaesthetic drugs

---

### INTRODUCTION

- These are the agents, which block the conduction of nerve impulses at the site of injection.
- It produces autonomic nervous system blockade, sensory anaesthesia, and skeletal muscle paralysis in the area innervated by the affected nerve.
- The local injections produce only local effects, but if the dose is exceeded, or the drug accidentally has intravenous access, systemic side effect can occur.

### LEARNING OBJECTIVES:

- Basic pharmacology of local anaesthetic (LA) drugs
- Commonly used local anaesthetic agents information, its preparation
- Doses and administration, Indications and contraindications
- Prevention, recognition and management of LA related complications

### LOCAL ANAESTHETIC AGENTS

The first clinical use of LA was in the form of cocaine for ophthalmic anaesthesia by Karl Koller in 1884. Lignocaine was first used clinically in 1944 by Nils Lofgren, and Bupivacaine was first synthesised in 1957 and introduced clinically in 1965.

#### Mechanism of action

- Local anaesthetic reversibly blocks nerve impulse conduction by binding to various receptor sites on the voltage-gated sodium channels intracellularly (after crossing the lipid bilayer of the axons) and inhibiting sodium influx.
- LA does not affect the resting membrane potential of a nerve.
- Hydrophobicity delivers the drug to the receptor and charge keeps it there
- Onset and recovery from blockade are governed by the relatively slow diffusion of local anaesthetic molecules into and out of the axon
- Factors that determine the efficacy of local anaesthetics are their pH, dissociation constant (pKa), lipid solubility, protein binding and the length of the intermediate chain.
- Efficacy can be augmented by the use of adjuncts such as adrenaline, opioids, alpha 2-adrenergic agonists and alkalinisation
- The sequence of the blockade with local anaesthetic agents

- Sympathetic (vasodilatation) (Type B fiber)
- Pain and temperature sensation (Type C and type A delta)
- Proprioception (Type A gamma)
- Touch and pressure sensation (Type A beta)
- Motor function (Type A alpha)

Chemically, they are classified as esters and amides depending on the intermediate chain between the lipophilic aromatic ring and the hydrophilic amine group. The ester and amide local anaesthetics differ in their chemical stability, locus of biotransformation, and allergic potential. Amides are extremely stable, whereas esters are relatively unstable in solution

#### ➤ Clinically used aminoamides

- Lignocaine
- Bupivacaine (racemic and its levo-enantiomer),
- Ropivacaine
- Mepivacaine
- Prilocaine
- Etidocaine

#### ➤ Commonly used aminoester local anaesthetics

- Chlorprocaine
- Procaine
- Tetracaine

#### Duration of Action

- Short: Procaine and Chlorprocaine
- Moderate: Lidocaine, Mepivacaine, and Prilocaine
- Long: Tetracaine, Bupivacaine, Ropivacaine, and Etidocaine

Lesser local anaesthetic is needed for subarachnoid blockade than that for peripheral nerve blocks and epidural anaesthesia because of greater access of LA to unprotected nerves in the subarachnoid space. There, it acts on the preganglionic fibres as they leave the spinal cord in the anterior rami.

#### Pharmacokinetics

##### Absorption

- Site of injection, dosage, volume, the addition of vasoconstrictor and drug profile
- Blood concentration is highest after intercostal nerve block > caudal epidural space > lumbar epidural space > brachial plexus > subcutaneous tissue

##### Distribution

- Two-compartment model
- Determined by the physicochemical properties of the drugs being used, protein binding, lipid solubility, and local blood flow

## Biotransformation and Excretion

- Esters undergo hydrolysis by plasma and liver cholinesterases and generally have a shorter duration of action than amides.
- The aminoamide drugs undergo enzymatic degradation primarily in the liver
- Excretion of the metabolites via the kidney. Less than 5% of the unchanged drug is excreted via the kidney
- p-Aminobenzoic acid is one of the metabolites of ester-type compounds that can induce allergic-type reactions in a small percentage of patients.

## Placental transfer:

- Local anaesthetics, because of their molecular size and high lipid-solubility, readily reach the foetus by passive diffusion.
- Bupivacaine < Lignocaine < Prilocaine
- Ester local anaesthetics, because of their rapid hydrolysis, are not available to cross the placenta in significant amounts.
- Although placental clearance of drug back to the mother in foetus and, a large volume of distribution in neonates provide some degree of protection, systemic toxicity can still occur in preterm neonates after large dose of LA in mother
- Acidosis in the foetus due to any cause like prolonged labour, can result in accumulation of local anesthetic molecules in the foetus (ion trapping)

## Alteration by patient status

- Elimination half-life increases with age
- The drug in newborns have a longer half-life
- Elevated plasma levels of LA are found in the presence of congestive heart failure impaired liver function, renal failure, extremes of age and sepsis

## Pregnancy and local anaesthetic drugs

- Enhanced neuronal sensitivity to local anaesthetics is seen during pregnancy. Possible reasons are progesterone; higher pH, lower bicarbonate and total carbon dioxide content in cerebrospinal fluid (CSF)
- Pregnant women require smaller doses of LA compared with nonpregnant women for neuraxial blockade
- Decreased protein binding during pregnancy leads to an increase in the free fraction of the drug

## Clinical uses of LA

- Central neuraxial blockade
- Infiltration anaesthesia
- Peripheral nerve blockade
- Intravenous Regional Anaesthesia (IVRA) or Bier's block
- Perineural and plexus infusion
- Topical anaesthesia
- Tumescence anaesthesia

- Systemic for neuropathic pain
- To reduce perioperative stress and to improve outcomes- 1.5-mg/kg lidocaine bolus 90 seconds before intubation or extubation
- To treat dysrhythmias

### Dosing

- Maximum up to 3-4 mg/kg lignocaine without adrenaline; up to 7 mg/kg of lignocaine with adrenaline.
- Bupivacaine, Levobupivacaine, Ropivacaine- up to 2.5 mg/kg
- Dosing should be decreased in extremes of ages, liver & kidney dysfunction and pregnancy
- Preservative-free and epinephrine free lignocaine only to be used for IVRA and as antiarrhythmic

### Lignocaine (Lidocaine)

- Lignocaine can be used for any type of local anaesthetic procedure, and an aqueous solution of the hydrochloride is non-irritating and highly stable.
- Lignocaine solution may contain 1:200,000 or 5 µg adrenaline/mL; antioxidants, such as metabisulfite (some controversy about whether it causes neurotoxicity) and ethylenediaminetetraacetic acid (EDTA, associated with allergic reactions) or antimicrobials, such as paraben derivatives, which are generally avoided in neuraxial and intravenous use out of concern for cytotoxic effects and allergic reactions
- 70% plasma protein-bound
- It is metabolised by the liver to xylidides which is excreted by the kidney, also excreted by lungs. Only 10% is excreted in the urine unchanged. The rate of metabolism is decreased in severe liver disease by impairment of hepatic blood supply and is increased by the induction of liver enzyme activity by barbiturates.
- Lignocaine has a duration of action of 60-90 min, which can be prolonged by the addition of adrenaline. For infiltration analgesia, 0.5- 1 % solution is employed while nerve blocks and extra-dural anaesthesia require concentrations of 1-2%.
- In healthy patients, a dose of 3-4 mg/kg (without adrenaline) or 7 mg/kg (with adrenaline) can be administered. Lignocaine is an excellent surface analgesic; 2% solution is used in ophthalmic work and up to 4% for topical anaesthesia of the mouth and the air passages. Other preparations include a 2% jelly lozenge containing 250 mg and a 5% ointment.
- Dose of lignocaine for spinal anaesthesia for caesarean section- 2, 2.5 or 3 ml of glucose-free 2% lignocaine. However, cauda equina syndrome, sacral nerve root deficits, or transient neurologic toxicity can occur after subarachnoid injection of lignocaine

### Bupivacaine:

- Bupivacaine is about four times more potent and more toxic than lignocaine, with a duration of nerve-blocking effect some 3-4 times longer. For nerve blocks, the maximum recommended dose in any 4 h period is 2 mg/ kg. Bupivacaine is highly cardiotoxic, so the recommended dose should never be exceeded.
- Available as racemic mixtures. S form is less neurotoxic and cardiotoxic than racemic mixtures
- 95% plasma protein-bound
- For spinal anaesthesia in LSCS, 0.5% hyperbaric (made hyperbaric by adding 8.25% dextrose)

and preservative-free bupivacaine is used in the dosage of 1.8 to 2.4 ml

- Preservative-free 2-chloroprocaine solutions (2% and 3%) and 0.5% or 0.75% ropivacaine have also be used for spinal anaesthesia

### Ropivacaine

- In contrast to bupivacaine, which is racemic. mixture ropivacaine and levobupivacaine have been developed as a pure S enantiomers.<sup>3</sup> These S enantiomers are considered to produce less neurotoxicity and cardiotoxicity than racemic mixtures or the R enantiomers of local anaesthetics
- Long-acting (4-8 hours)
- Less potent and less cardiotoxic than bupivacaine- clearance of ropivacaine is higher than bupivacaine, and its elimination half-time is shorter.
- Also produces lesser motor blockade compared to bupivacaine

### Adverse effects

- **Allergic reactions**- more common with the esters because of their p-aminobenzoic acid metabolites. Allergic reaction to an amide is rare.
- **Direct neurotoxicity**- associated with large-volume or high concentrations LA injections, and injections producing localised pressure on the nerve; direct needle trauma and intraneural injections have
- **Transient neurologic syndrome or cauda equina syndrome**- associated with chloroprocaine or lignocaine use in a subarachnoid block, the use of microcatheters for continuous spinal anaesthesia (although described in single-shot injections) and intraoperative lithotomy. Features of this syndrome include localised back pain, radiculopathies, paresthesias or hypoesthesia.
- **Methaemoglobinemia**- seen with large doses ( $> 10$  mg/kg) of prilocaine (metabolite 0-toluidine), tertacaina and benzocaine
- Indirect effects related with high levels of spinal/epidural blockade- discussed in relevant module
- **Local anaesthetic systemic toxicity (LAST)**

### Signs and symptoms of LAST

#### CNS manifestations

- Can start with mild symptoms like light headedness, circumoral numbness, metallic taste, dizziness, and tinnitus, progressing to nystagmus, twitching, convulsions, coma, cardiopulmonary arrest, and death.
- Factors increasing CNS toxicity- potency of LA, respiratory or metabolic acidosis
- Increased PaCO<sub>2</sub> increase CBF thus more LA reaches, increased intracellular pH cause Ion trapping

#### CVS manifestations

- LA produce dose-dependent reduction in contractility, pacemaker activity and impulse conduction throughout the myocardium. They also have vasodilator property. This is manifested as severe dysrhythmias, conduction blocks, hypotension and cardiac arrest.
- The CVS effects are more resistant to treatment than the central nervous system.

- The ratio between the dose required for cardiovascular collapse (CC) versus CNS toxicity, or the CC-to-CNS dose ratio, is approximately 7.1 for lidocaine and 2.0 for bupivacaine. Thus lower margin of safety with bupivacaine. This margin of safety is even lower in pregnancy.

### Management of local anaesthetic systemic toxicity

- Stop injecting the local anaesthetic
- Call for help
- Airway, Breathing, Circulation
- Position patient with left uterine displacement
- Consider delivery of the infant if the mother is not resuscitated within several minutes, because this may facilitate greater chances of resuscitation of the mother too
- Consider 20% lipid emulsion administration at the first sign of LAST
  - Bolus dose: 1.5 mL/kg over 2–3 min (approximately 100 mL) IV
  - Infusion: Start with 0.25 ml/kg/ minute increase to 0.5 ml/kg/minute, if haemodynamic stability is not attained
  - Recommended maximum dose: 12 mL/kg
- Administer 100% oxygen
  - Assist ventilation if necessary
  - Tracheal intubation will facilitate support of ventilation and help protect the airway but do not delay the administration of oxygen to intubate the trachea.
- Control seizure (benzodiazepine preferred, avoid high doses of propofol in haemodynamically unstable patients). Be aware that hypoxaemia and acidosis develop rapidly during a seizure.
- Alert the nearest facility capable of cardiopulmonary bypass/ ECMO.
- Monitor mother and foetus
- Supportive treatment- fluids and vasopressors.
- Initiate advanced cardiac life support if necessary, including modifications for pregnancy
- Avoid vasopressin, calcium channel blockers, beta blockers, and local anaesthetics.
- Should not administer adrenaline boluses in more than 1 µg/kg dose
- For ventricular arrhythmias amiodarone may be considered

Source: 1. *Chestnut's Obstetrics Anesthesia*

2. *Checklist for treatment of local anesthetic systemic toxicity (LAST).*

[https://www.asra.com/content/documents/asra\\_last\\_checklist\\_2018.pdf](https://www.asra.com/content/documents/asra_last_checklist_2018.pdf).

LAST can be prevented by avoiding intravascular injection, injecting incrementally, and using the smallest dose needed to achieve the desired clinical effect.

### KEY LEARNING POINTS:

- Local anaesthetics block the neural transmission by acting on the sodium channels
- We should be aware of the correct way of using it and side effects associated with its use
- Knowing the correct dose of each route of administration, dose limitations of LA, injecting in incremental dose, using smallest effective dose & concentration and avoiding intravascular

injections are some of ways of safe use of LA.

- Early recognition, prompt treatment and if needed, early delivery is the key to the management of local anesthetic systemic toxicity

## CHECK YOUR PROGRESS

Q1. All of the following influence duration of local anesthesia EXCEPT:

- A. Addition of adrenaline to the formulation
- B. Dissociation constant (pKa) of the local anaesthetic
- C. Relative protein binding affinity of the local anaesthetic
- D. Relative vasodilating property of the local anesthetic

Q2. The risk for direct neurotoxicity from local anaesthetics is most closely associated with which of the following characteristics?

- A. Greater concentration
- B. Greater lipid solubility
- C. Higher pH
- D. Lower pKa

Q3. Baricity of local anesthetics is the term used relative to

- A. Water
- B. Atmosphere
- C. CSF
- D. Fat

Q4. A solution of LA contains 1:200,000 adrenaline. How much adrenaline has been added?

- A. 5 µg/mL
- B. 50 µg/mL
- C. 0.5 µg/mL
- D. 0.05 µg/mL

Q5. Which of the following is an ester LA?

- A. Bupivacaine
- B. Chlorprocaine
- C. Lignocaine
- D. Ropivacaine

### Answers

1-D, 2- A, 3-C, 4- A, 5- B

### Further reading

1. Stoelting's Pharmacology and Physiology in anesthetic practice
2. Chestnut's Obstetrics Anesthesia



# Week 11 - Module

## Pharmacology II- Emergency drugs



# 43

## Emergency and cardiac drugs

### SAFE IN PREGNANCY

- a. Antihypertensive agents such as methyldopa, labetalol, calcium channel blockers, and hydralazine
- b. Dopamine, dobutamine, or digoxin- Monitoring of digoxin level to be done

### DRUGS TO BE AVOIDED IN PREGNANCY

- a. Angiotensin-converting enzyme inhibitors (ACEIs) and angiotensin receptor blockers (ARBs)
- b.  $\beta$  blockers except labetalol should be avoided, although atenolol and metoprolol are often used during pregnancy
- c. Spironolactone
- d. Amiodarone during the first trimester- theoretical risk of hypothyroidism

### ANTIHYPERTENSIVE AGENTS USED DURING PREGNANCY

No antihypertensive has been proven to be completely safe during the first trimester

#### For hypertensive crisis

Drug	Mechanism of action	Onset time (in minutes)	Dosing	Side effects	Contraindications
Intravenous					
Labetalol	$\alpha$ and $\beta$ adrenergic antagonism – fixed 1:7 ratio	5 - 10	20 to 80 mg bolus every 10 mins or 40mg/h as an infusion	Neonatal bradycardia	Avoided in severe asthma and CHF
Hydralazine	Arterial dilator	10 -20	5 mg bolus every 20 minutes or 10 mg/h as an infusion	Maternal hypotension, palpitations, headache, neonatal bradycardia	SLE, Renal impairment, MI

Drug	Mechanism of action	Onset time (in minutes)	Dosing	Side effects	Contraindications
Nifedipine	CCB long-acting	10-20	10 mg every 20 minutes 240 mg /24 h	Potential concerns severe hypotension and neuromuscular blockade with MgSO <sub>4</sub>	ACS, Aortic stenosis, Heart failure
Nicardipine	CCB	10 -15	5 mg/h, increase infusion by 2.5 mg/ h till maximum dose of 15 mg/h is reached	Same as Nifedipine	Same as Nifedipine
Esmolol	Short acting $\beta$ blocker	1-2	50 to 200mcg / kg /min infusion Or 0.1 to 0.5 mg/kg IV boluses	Foetal bradycardia	Same as labetalol

## ORAL MEDICATIONS

Drug	Dose	Safety	Side effects
<b>Methyldopa</b> Drug of choice	0.5–3 gm/day in 2 to 4 divided doses	Proven safety and efficacy	Depression, hepatic disturbances, haemolytic, anaemia -may not, lower BP adequately
<b>Labetalol</b>	200–1200 mg/day p.o. in 2–3 divided doses	Safety similar to methyldopa may be more efficacious than methyldopa;	May be associated with foetal growth restriction. Neonatal hypoglycemia with larger doses
<b>Nifedipine</b> Long-acting	10–30 mg p.o.	widely used	May prolong labour; Rarely, profound hypotension if short-acting agent is used with magnesium
<b>Verapamil</b>	80mg tds p.o.	Similar efficacy to other oral agents	Risk of interaction with magnesium – bradycardia

<b>Clonidine</b> Alternative option	0.1–0.6 mg/day in 2 divided doses	Safety similar to methyldopa Limited data on foetal safety	Efficacy similar to methyldopa
<b>Hydrochlorothiazide</b> Useful in chronic hypertension	12.5–25 mg/day		Volume contraction, electrolyte abnormalities – rare with small doses

## Cardiac Glycosides (Digoxin & Digitoxin)

- **Actions:**
  - Heart: Positive inotropic effect, ↓ Heart Rate
  - Blood Vessels: Mild direct vasoconstriction
  - Kidney: Diuresis in CHF patient
  - CNS: ↑ Doses causes CTZ activation Nausea, and Vomiting.
  - **Adverse events:** - Anorexia, nausea, vomiting, arrhythmia: Pulsus bigeminus, ventricular tachycardia, extra-systole, A-V Block.
- **Contraindications**
  - Hypokalemia: Enhances toxicity.
  - Thyrotoxicosis: arrhythmias.
  - VT: May precipitate VF.
  - Partial A-V Block: May convert to complete block.
- **Uses:**
  - CHF (Primarily mitigate systolic dysfunction).
  - Cardiac Arrhythmia.
  - Atrial Fibrillation-drug of choice for controlling ventricular rate.
  - Atrial Flutter: Enhances A-V Block.
  - PSVT: Increases vagal tone.

## Antiarrhythmic Drugs

- **Class 1:** Membrane stabilising agent (Sodium channel blockers)
- **Subclass 1A:** Open state Na channel Blockers Reduce automaticity.
  - Quinidine: ↓ Rate of phase 0 depolarisation.
  - Procainamide: Amide derivative of Local anaesthetic procaine. Action similar to Quinidine.
  - Disopyramide: Cardiac depressant and Anticholinergic action.
  - Uses: Prevention of recurrence of ventricular arrhythmia
- **Subclass 1B:** Block Na Channel in both activated and inactivated state.
  - Lignocaine: Commonly used local anaesthetic.

- Suppression of automaticity in Ectopic Foci.
- Use: Ventricular Tachyarrhythmias following MI and Cardiac surgery. Useful in digitalis toxicity.
- Phenytoin: It is an anti epileptic drug.
  - Automaticity in Purkinje Fibres & Ventricle.
  - Useful in Digitalis Toxicity
- **Subclass 1C:** Block Na Channel in open state depress conduction. Propafenone, Flecainide.
- **Class II:  $\beta$  Blockers:**
  - Propranolol: Cardiac adrenergic blockade ↓ Slope of Phase 4 Depolarization & Automaticity in SA Node, PF and other Ectopic Foci under Adrenergic influence.
  - Sotalol.
  - Esmolol: Short-acting.
  - A/E: Bradycardia, Exacerbate COPD, Exacerbate variant angina.
- **Class III:**
  - **Amiodarone:**
    - Blocks myocardial K<sup>+</sup> channels Prolongs action potential duration.
    - The effective refractory period is increased.
    - Conduction is slowed.
    - Ectopic automaticity is decreased.
    - Uses: Resistant VT, Recurrent VF, to maintain Sinus rhythm in AF.
  - Long-acting: Used as a long-term prophylactic drug
    - A/E: Hypotension, Nausea, Photosensitization, Peripheral neuropathy, Hypothyroidism
  - Bretylium:
    - Action similar to Amiodarone.
    - Used for VF refractory to Electrical defibrillation
- **Class IV:**
  - Verapamil: Ca Channel blocker.
    - Action: Prolongation of A-V nodal effective refractory period- A-V conduction is slowed.
    - Uses: PSVT.
  - Diltiazem:
    - Action similar to Verapamil.

## Antianginal and Anti-ischaemic Drugs

### Nitrates:

- **Example:**
  - Glycerol trinitrate.
  - Isosorbide di-nitrate.
  - Isosorbide mono-nitrate.

- **Mechanism of Action:**

Organic nitrates

Nitric oxide interferes with activation of myosin, ↓ Smooth muscle contraction.

- **Uses:**

- Preload reduction.
- Afterload reduction.
- Angina pectoris.
- CHF.
- MI.
- Cyanide poisoning
- **Adverse effects:** Headache, methaemoglobinaemia, flushing, sweating, lethargy, tolerance, rashes.
- **β-Blockers:** Propranolol, Esmolol, Atenolol, Metoprolol, Sotalol.

- **Mechanism of Action:**

Act by decreasing cardiac work and O<sub>2</sub> consumption.

- **Uses:**

- Hypertension/ Arrhythmia
- MI/ Angina pectoris: Decreased severity and frequency of attacks, increased exercise tolerance.
- Anxiety/Migraine/Glaucoma.

- Should be taken regularly, should not be abruptly stopped.

## Calcium Channel Blockers:

- **Example:**

- Verapamil.
- Diltiazem.
- Nifedipine.

- **Mechanism of Action:**

- Smooth muscle relaxation, Negative chronotropic, Inotropic and Dromotropic effects.

- **Uses:**

- Verapamil/Diltiazem (When β Blocker is Contraindicated).
- Hypertension.
- Arrhythmia.
- Hypertrophic Cardiomyopathy.

## K<sup>+</sup> Channel Openers:

- **Example:** Nicorandil.

- **Mechanism of Action:**



By causing vasodilatation, including coronary vessels.

• **Side effects:**

Flushing, Palpitation, Weakness, Headache, Nausea.

## EMERGENCY DRUGS OTHER THAN SYMPATHOMIMETICS

### Atropine

- An alkaloid from *Atropa belladonna*
- It is a racemic mixture of D- and L-hyoscyamine (L-form is active)

#### Presentation

- Injection contains 0.5/0.6 mg/ml of atropine sulphate
- Also available as 0.6 mg tablets

#### Mechanism of action

- Anticholinergic
- Competitive antagonism of acetylcholine at muscarinic receptors with little effect at nicotinic receptors, except at high doses)
- The effect is most noticeable in healthy young adults (considerable vagal tone)
- Larger doses required in infancy and old age

**CVS-** initial bradycardia (Bezold– Jarisch reflex), followed by tachycardia, increased CO with little effect on BP, decreases the AV conduction time

**Respiratory System-** bronchodilation with an increase in the physiological dead space, decreased bronchial secretions/ salivation, increased respiratory rate, decreased incidence of laryngospasm

**CNS-**Central excitation or depression (central anticholinergic syndrome)- > 5 mg dose, somnolence, confusion, amnesia, agitation, hallucinations, dysarthria, ataxia, or delirium.

Atropine also has antiemetic and anti-parkinsonian actions; Cycloplegia, mydriasis, and an increase in intraocular pressure

Inhibition of sweating, increased BMR, has local anaesthetic properties

**Kinetics-**50% protein-bound in the plasma, the volume of distribution is 2.0–4.0 l/kg

- It crosses the placenta and blood–brain barrier
- Elimination half-life is 2.5 hours.

#### Uses

- Bradycardia: 0.5 mg or 10µg/kg IV bolus, up to 3 mg (total vagolytic dose)
- Reversal of muscarinic effects of anticholinesterase: 1.2 mg for every 2.5 mg neostigmine
- Organophosphate poisoning: 1–2 mg initially, then further 1–2 mg every 30 min
- Tetanus



- As a cycloplegic- 1% atropine eye drops
- Reduces the incidence and morbidity of oculocardiac reflex

#### How not to use atropine ?

- Slow IV injection of doses <0.3 mg (bradycardia caused by medullary vagal stimulation)

**Adverse effects** Drowsiness, confusion, dry mouth, blurred vision, urinary retention, pyrexia (suppression of sweating), atrial arrhythmias and atrioventricular dissociation

#### Cautions

- Elderly (↑ CNS side-effects)
- Child with pyrexia (further ↑ temperature)
- Acute myocardial ischaemia or MI (tachycardia may cause worsening)
- Prostatic hypertrophy–urinary retention (unless patient’s bladder catheterised)
- Acute-angle glaucoma (further ↑ IOP)

Pregnancy (fetal tachycardia)

### Nitroglycerine

- An ester of nitric acid
- Causes dilation of both arteries and veins.
- Mode of action- metabolised to nitric oxide (NO) which stimulates guanylate cyclase in the vascular smooth muscle cells, resulting in the relaxation of smooth muscles.
- Glyceryl trinitrate reduces venous return (preload) and facilitates subendocardial blood flow with redistribution into ischaemic areas
- It relieves coronary vasospasm and dilates arterioles, reducing afterload, and is thought to relieve angina primarily by reducing myocardial oxygen demand (secondarily to a fall in left ventricular end-diastolic pressure and myocardial wall tension)
- Myocardial oxygen supply is simultaneously increased by redistribution of the coronary blood flow to the subendocardium
- Respiratory System- bronchodilatation; intrapulmonary shunting may increase
- Absorption- rapid and efficient after sublingual administration
- Significant first-pass effect
- VD is 0.04–2.9 l/kg
- Metabolism- rapidly metabolised in the liver and red blood cells by reduction to dinitrates, mononitrates, and nitrites
- Excretion 80% is excreted in the urine; trace amounts are exhaled as CO<sub>2</sub>.
- Elimination half-life is 1–3 minutes
- Clinically significant tolerance does not occur with continued intravenous administration of the drug

#### Uses

## Treatment of

1. Stable, unstable, and variant angina
2. Left ventricular failure secondary to myocardial infarction
3. In the perioperative control of blood pressure
4. For the prophylaxis of thrombophlebitis associated with venous cannulation
5. Decreases infarct size in patients with acute myocardial infarction
6. To promote venodilation

Toxicity/side effects- Hypotension, sinus tachycardia, and occasionally bradycardia, nausea, and vomiting may result from administration of the drug

- Tachyphylaxis
- Headaches more common with oral or sublingual than with intravenous administration

## Sodium nitroprusside

Chemical- An inorganic complex

### Mechanism of action

- Dilates both resistance and capacitance vessels by direct action on vascular smooth muscle- arterial and venodilator
- Act by interacting with sulfhydryl groups in the smooth muscle cell membrane, thereby stabilising the membrane and preventing the  $\text{Ca}^{2+}$  influx necessary for the initiation of contraction
- Hypotension and compensatory tachycardia

Dose- 0.25 to 2mcg/kg/min in pregnancy

Onset of action- immediate

### Kinetics

- VD is approximately the same as the extracellular space (15 l)
- Metabolism- hepatic rhodanese to form thiocyanate, cyanide ions react with hydroxycobalamin to form cyanocobalamin (vitamin B12)
- Excretion Both thiocyanate and cyanocobalamin are excreted unchanged in the urine
- The elimination half-life of the former is 2.7 days
- Special points sodium nitroprusside is removed by haemodialysis

### Uses

- Hypertensive crises
- Aortic dissection prior to surgery
- Left ventricular failure
- To produce hypotension during surgery

### Toxicity/side effects

- Sudden hypotension, tachycardia
- Cyanide toxicity- increased likelihood in hypothermia, malnutrition, vitamin B12 deficiency, and severe renal or hepatic impairment
- > 4 micrograms/kg/min should not be used
- Hypersensitivity, Congenital optic atrophy

### Naloxone

- Specific opioid antagonist
- Elimination half-life is 60–90 min, with a duration of action between 30 and 45 min.

### Uses

- Reversal of opioid adverse effects – respiratory depression, sedation, pruritus and urinary retention
- 200 µg IV bolus, repeat every 2–3 min until desired response, up to a total of 2 mg
- Infusion may be required in patients with renal impairment or those who had taken long-acting opioids
- Give 20 µg boluses every 5 min until symptoms resolve
- As a diagnostic test of opioid overdose in an unconscious patient

**Contraindications-** Patients physically dependent on opioids

### Cautions

- Titrate dose carefully in postoperative patients to avoid sudden return of severe pain
- Large doses should not be given quickly
- Hepatic failure- delayed elimination
- Adverse effects- Arrhythmias, hypertension

### Flumazenil

- A competitive antagonist at the BZD receptor.
- It has a short duration of action (20 min).

### Uses

- To facilitate weaning from ventilation in patients sedated with benzodiazepine
- In the management of benzodiazepine overdose
- As a diagnostic test for the cause of prolonged sedation

### Administration

- IV bolus: 200 µg, repeat at 1 min intervals until desired response, up to a total dose of 2 mg
- If re-sedation occurs, repeat dose every 20 min

- Ensure effects of neuromuscular blockade reversed before using flumazenil

### Contraindications

- Tricyclic antidepressant and mixed-drug overdose (seizures)
- Patients on long-term benzodiazepine therapy (withdrawal)
- Epileptic patients on benzodiazepines (seizures)
- Patients with raised ICP (further increase in ICP)

### Cautions

- Re-sedation – requires prolonged monitoring if long-acting benzodiazepines have been taken
- Hepatic dysfunction: reduced elimination

**Adverse effects** Dizziness Agitation Arrhythmias Hypertension Seizures

## Sodium bicarbonate

- **Chemical**- An inorganic salt

### Mode of action

- The compound freely dissociates to yield bicarbonate ions which represent the predominant extracellular buffer system
- Each gram of sodium bicarbonate will neutralise 12 mEq of hydrogen ions

### Presentation

- Clear, colourless, sterile solution containing 1.26/4.2/8.4% w/v sodium bicarbonate in an aqueous solution
- 8.4% solution contains 1 mmol/ml of sodium and bicarbonate ions and has a calculated osmolarity of 2000 mosm/L

- **Dose** (mmol) = [base deficit (mEq/l) × body weight (kg)]/3
- Half this amount is administered before the acid-base status is reassessed

### Uses

- Correction of profound metabolic acidosis
- Alkalinisation of urine and
- As an antacid
- Routine use of sodium bicarbonate during cardiac arrest is not recommended

### Cautions

- Overenthusiastic correction- metabolic alkalosis- myocardial dysfunction and peripheral tissue hypoxia due to a shift in the oxygen dissociation curve to the left
- Hyperosmolarity

- Hyponatremia
- Irritant to tissues- extravasation- necrosis
- Do not let sodium bicarbonate come into contact with catecholamines (inactivates) or calcium salts (precipitates)

## Potassium chloride

### Uses

- Hypokalaemia
- In cardioplegic solution & organ preservation solution

### Contraindications

- Severe renal failure
- Severe tissue trauma
- Untreated Addison's disease

### Cautions- Concurrent use of potassium-sparing diuretics or ACE-I

- Hypokalaemia is frequently associated with hypomagnesaemia
- Concentrations greater than 40 mmol/l should be administered centrally
- Monitor serum potassium regularly
- Check serum magnesium in refractory hypokalaemia

### Adverse effects Muscle weakness Arrhythmias ECG changes

## Calcium chloride/ gluconate

- Adequate levels of ionised calcium are necessary for effective cardiovascular function
- The chloride salt is preferred to the gluconate salt, as it does not require hepatic metabolism to release the calcium ion
- 10 ml 10% calcium chloride provides 6.8 mmol Ca<sup>2+</sup>
- 10 ml 10% calcium gluconate provides only 2.25 mmol Ca<sup>2+</sup>

### Uses

- Hypocalcaemia
- Hyperkalaemia
- Calcium-channel antagonist overdose

### Caution

- Calcium overload is thought to play an important role in ischaemic and reperfusion cell injury
- It may also be implicated in coronary artery spasm

## CRASH/ CODE BLUE CART CHECKLIST

### Drugs

1. Adenosine
2. Adrenaline
3. Amiodarone
4. Anticonvulsants- Phenytoin, Verapamil, Levetiracetem
5. Aspirin tablets
6. Atropine
7. Beta blockers- Esmolol, Metoprolol
8. Calcium gluconate/ chloride
9. Chlorpheniramine maleate (Avil)
10. Dextrose- 50%, 25 %
11. Dantolene sodium- 36 vials
12. Deriphylline
13. Dexmedetomidine
14. Diltiazem
15. Dobutamine
16. Dopamine
17. Ephedrine/ Mephenteramine
18. Flumazenil
19. Furosemide
20. Heparin
21. Hydroxyethyl starch
22. Hydrocortisone/ Dexamethasone/ Methylprednisolone
23. Induction agents- Thiopentone sodium, Propofol, Ketamine, Etomidate
24. Inhalers- Salbutamol, Ipratropium bromide, Budecort, Duolin; respules also to be kept
25. Isoprenaline
26. IV fluids- NS (500 ml, 100 ml, 10 ml vials), RL, Plasmalyte
27. Labetalol
28. Lipid emulsion 20%
29. Lignocaine- Xylocard
30. Magnesium sulphate- 50 %
31. Midazolam
32. Morphine
33. Naloxone
34. Nitro-glycerine injection/ spray/ patch
35. Noradrenaline
36. Potassium chloride

37. Phenylephrine
38. Sodium bicarbonate
39. Succinylcholine/ rocuronium
40. Vasopressin
41. Xylometazoline/saline nasal drops

### Equipments

1. Alcohol swab/ chlorhexidine
2. AMBU bag with mask & reservoir- adult, paediatrics, neonate
3. Ampoule breaker
4. Arterial cannulas
5. Bain's circuit, T-piece- Jackson Rees circuit
6. Bougie- paediatric & adult
7. Blood Transfusion and IV fluid administration sets
8. Central line with availability of central line insertion set
9. Defibrillator with ECG monitor; external pacing facility; check charging and gel
10. ECG electrodes
11. Endotracheal tubes- all sizes (Adult and Neonates)
12. ETT fixations (Adhesive or cotton tape)
13. Extra power battery (Battery Cells for laryngoscopes)
14. Face mask- all sizes
15. Flow charts- BLS, ACLS, Neonatal resuscitation, Important phone numbers
16. Obstetrics emergencies management guide
17. Glucometer with glucosticks
18. Gloves- sterile & non-serile; sizes- 6.5- 7.5
19. Infusion pumps in the vicinity
20. IV cannulas- 24G to 14G
21. IV set
22. Laryngoscopic handles and blades of all sizes
23. Lignocaine gel- 2 %
24. Lignocaine spray
25. Magill's forceps- small & big
26. Monitor- ECG, SpO<sub>2</sub>, ETCO<sub>2</sub>, NIBP
27. Nasopharyngeal airways- all sizes
28. Needles- various sizes
29. Oral airways- all sizes
30. Oxygen cylinder with regulator and opening key attached
31. Oxygen masks (simple and with nebuliser port)- adult & paediatric; nasal prongs



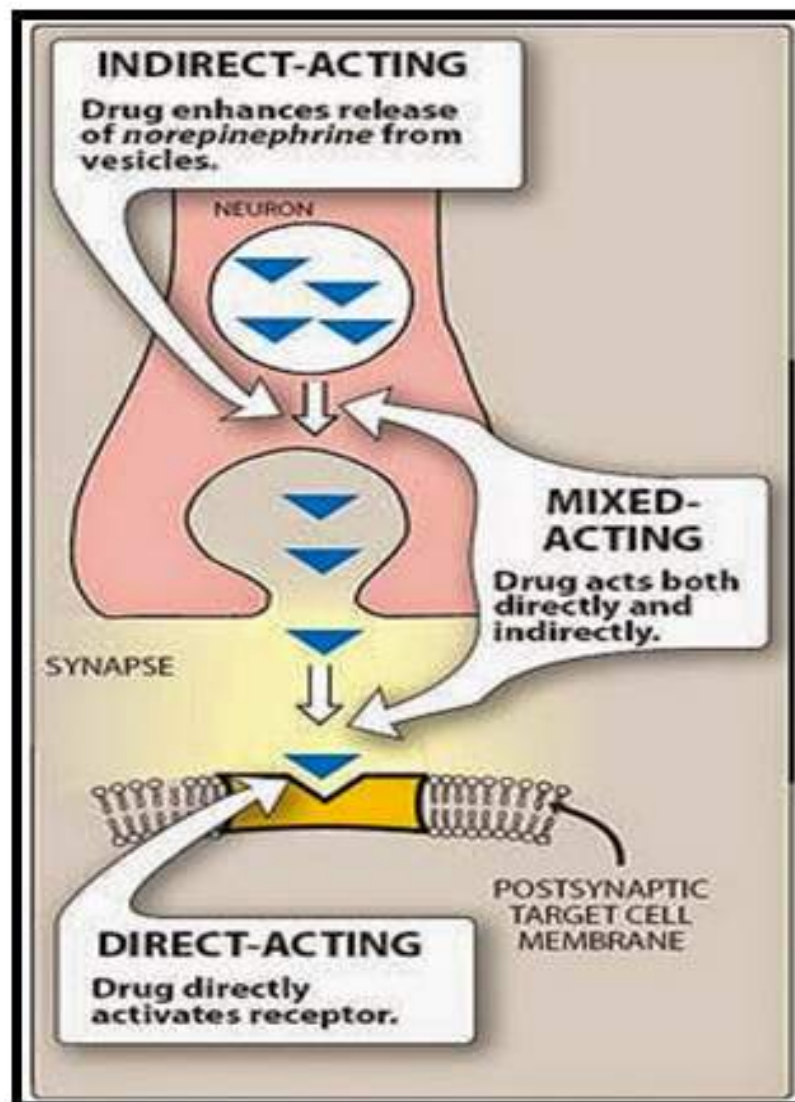
32. PMO lines- male to male, male to female
33. Pressure bags
34. Razor
35. Ryle's tube- 14 F, 16 F
36. Scissors
37. Sharp disposal container
38. Stylets for ETT- paediatric & adults
39. Suction catheters
40. Suction apparatus availability
41. Supraglottic airways- l-gel, Laryngeal mask airways
42. Syringes- 1 ml, 2 ml, 5 ml, 10 ml, 20 ml, 50 ml
43. Three ways
44. Torch
45. Transcutaneous pacing pads with cable connection to defibrillator
46. Writing pads

# 44

## Sympathomimetic Drugs

- Naturally occurring Catecholamines- Adrenaline / Epinephrine, Noradrenaline / Nor-epinephrine, Dopamine.
- Synthetic Catecholamines- Isoprenaline, Dobutamine
- Synthetic Non-catecholamines: Direct (Phenylephrine) and Indirect (Ephedrine, Mephentermine) acting.

### MECHANISM OF ACTION



## METABOLISM

- Catecholamines are inactivated by Monoamine Oxidases (MOA) or Catechol-O-Methyl transferases (COMT).
- Biologic effect is mainly terminated by UPTAKE back into postganglionic sympathetic nerve endings.
- Synthetic Non-catecholamines are not affected by COMT and are dependent on MAO (Patients on MAO inhibitors can manifest exaggerated response).

## TYPES AND SUBTYPES OF ADRENOCEPTORS

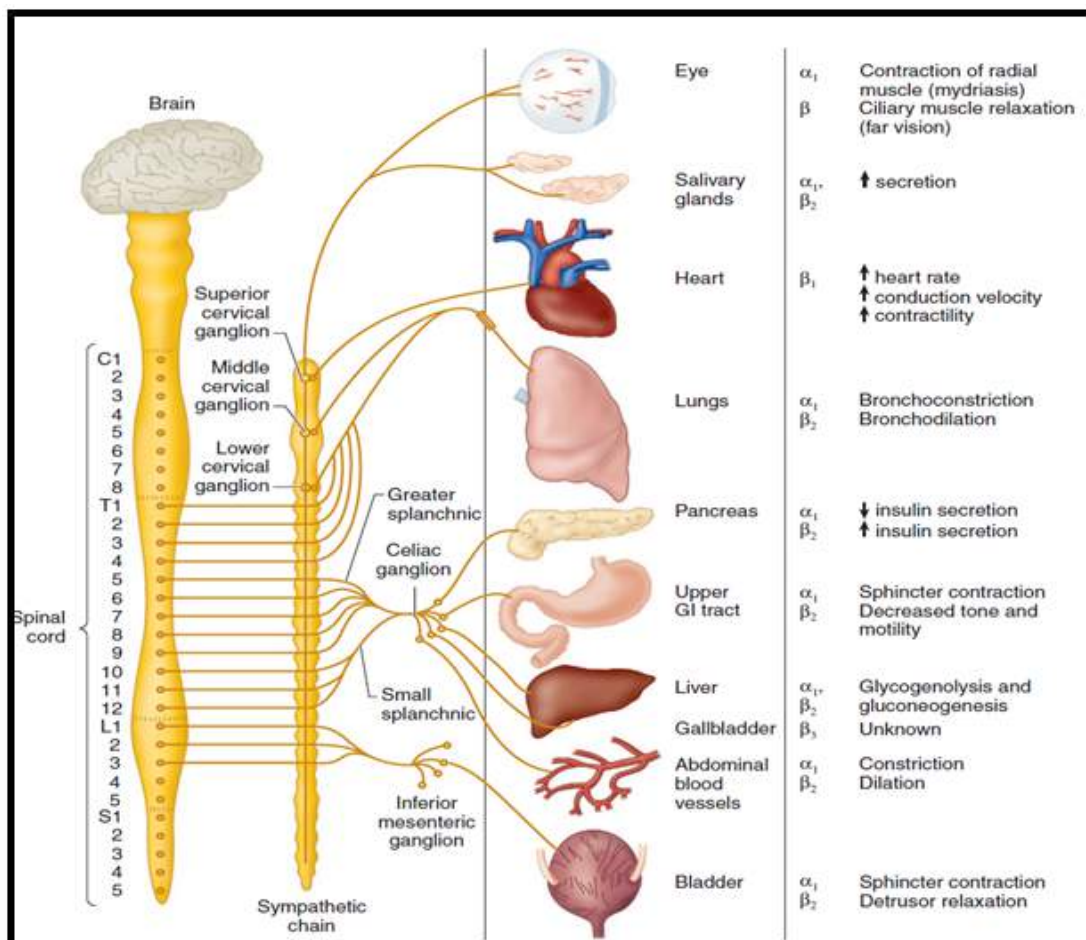
### Two subtypes of Adrenoceptors (Alpha and beta):

- Excitatory in most tissues**  
(Except - Intestinal smooth muscle)
- Inhibitory in most tissues**  
(Except - Heart)

### Rank Order of Potency:

1. Alpha receptors: Epi > NE >> Iso
2. Beta receptors: Iso > Epi > NE

## Adrenergic Receptors: Types and Actions



## RECEPTORS AND ACTIONS

The predominant alpha-adrenergic agonist responses are:

- Vasoconstriction and CNS stimulation.

The beta-adrenergic agonist response results in:

- Bronchial, GI and uterine smooth muscle relaxation.
- Glycogenolysis.
- Cardiac stimulation.

Dopaminergic Receptors:

- Stimulated by Dopamine.
- Causes dilation of renal, mesenteric, coronary and cerebral blood vessels, resulting in increased blood flow.

## Pharmacological Effects

- Vasoconstriction (Renal and Cutaneous Circulation).
- Vasodilatation (Skeletal Muscle).
- Bronchodilation.
- Cardiac stimulation (Increase Heart rate).
- Myocardial Contractility (Increases Irritability).
- Hepatic Glycogenolysis.
- Liberation of free fatty acids.
- CNS stimulation.
- Modulation of Insulin, Renin and Pituitary hormone

## Adrenomimetic Drugs

A. General agonists:

- **Direct ( $\alpha 1$ ,  $\alpha 2$ ,  $\beta 1$ ,  $\beta 2$ ):** Epinephrine, Ephedrine.
- **Indirect, Releasers:** Tyramine, Amphetamine, Ephedrine
- **Indirect, Uptake inhibitors:** Cocaine, Tricyclic antidepressants

B. Selective agonists:

- **$\alpha 1$ ,  $\alpha 2$ ,  $\beta 1$ :** Norepinephrine.
- **$\alpha 1 > \alpha 2$ :** Phenylephrine, Methoxamine
- **Dopamine agonist:** Dopamine, Bromocriptine

## Clinical Uses

- As Inotropes.
- As Vasopressors.

- Treatment of Bronchospasm (Including allergic reaction).
- Prolong duration of action of local anaesthetics.

## INDIVIDUAL DRUGS

### Adrenaline

Naturally occurring catecholamine

#### Preparation

- 0.1 or 1 mg/ml of adrenaline hydrochloride
- 1% topical ophthalmic solution (weak mydriatic)
- Aerosol spray delivering 280 micrograms metered doses of adrenaline acid tartrate

#### Mechanism of action

- Acts on both  $\alpha$ - and  $\beta$ -adrenergic receptors
- Low doses- predominantly  $\beta$ -effects, higher doses predominantly  $\alpha$ -effects
- $\beta$  1 stimulation -increase in HR and force of contraction- increase in cardiac output
- $\alpha$  1 stimulation- peripheral vasoconstriction, which increases the systolic BP
- $\beta$  2 stimulation –bronchodilatation (mild respiratory stimulant too) and vasodilatation in certain vascular beds (skeletal muscles)
- Consequently, total systemic resistance may actually fall, explaining the decrease in diastolic BP that is sometimes seen
- Metabolic effects- decreases insulin secretion whilst increasing both glucagon secretion and the rate of glycogenolysis, increased BMR, pyrexia
- Metabolized by catechol-o-methyl transferase, predominantly in the liver

#### Uses

- Cardiac arrest- asystole, PEA- 1 mg IV bolus, repeat every 3-5 minutes
- Low cardiac output states- 0.01–0.30  $\mu\text{g}/\text{kg}/\text{min}$  IV infusion via a central vein
- Bronchospasm- 0.5–1 mg in 5 ml NS nebulised
- Stridor/ croup- Nebulized racemic epinephrine- 2.25% solution, 0.05 ml/kg/dose, max 0.5 ml, diluted to 3 ml in normal saline
- Anaphylaxis- IV bolus: 0.5–1.0 ml 1 in 10000 solution (50–100  $\mu\text{g}$ ), IM dose- 10  $\mu\text{g}/\text{kg}$ , up to 500  $\mu\text{g}$ ; the dose may be repeated after 5 minutes
- To  $\downarrow$  bleeding in operative site: as a local vasoconstrictor, used by the surgical team in dilution of 1:1 lakh to 1: 2 lakhs diluted solution.
- Added to local anaesthetic solutions to prolong their duration of action

The dose of adrenaline should be limited to 1  $\mu\text{g}/\text{kg}/30$  minutes in the presence of halothane and to 3 micrograms/kg/ 30 minutes in the presence of sevoflurane or isoflurane- ventricular dysrhythmias

**Cautions-** Acute myocardial ischaemia, inadequate intravascular volume replacement, injection near end arteries, Peripheral vascular disease (PVD), Hyperthyroidism

### How not to use adrenaline?

- In the absence of haemodynamic monitoring
- Avoid flushing of line
- Incompatible with alkaline solutions and drugs, e.g. sodium bicarbonate, furosemide, phenytoin etc.

### Adverse effects-

- Arrhythmia, tachycardia, hypertension, myocardial ischaemia,
- Increased lactate levels
- CNS excitations
- Increases the cutaneous pain threshold and enhances neuromuscular transmission
- Decreases the tone of the urinary bladder & uterus

## Dopamine

- A naturally occurring catecholamine
- **Presentation-** As a clear, colourless solution for injection containing 40 mg/ml of dopamine hydrochloride (Supplied in 5 ml ampoules containing 200 mg Dopamine), can be diluted with NS/RL/ dextrose solution

### Mechanism of action

- Acts directly on  $\alpha$ ,  $\beta$  1 and dopaminergic receptors (D1 & D2) and indirectly by releasing noradrenaline
- Low doses (0.5–2.5  $\mu\text{g}/\text{kg}/\text{minute}$ ) increases renal and mesenteric blood flow by stimulating dopamine receptors-  $\uparrow$  GFR and  $\uparrow$  Renal sodium excretion- evidence lacking in renal protection
- Doses between 2.5 and 10  $\mu\text{g}/\text{kg}/\text{minute}$  stimulate  $\beta$  1 receptors causing  $\uparrow$  Myocardial contractility, stroke volume, CO, coronary blood flow
- Doses  $>10$   $\mu\text{g}/\text{kg}/\text{min}$ - predominant  $\alpha$  effects causing peripheral vasoconstriction,  $\uparrow$  SVR,  $\downarrow$  Renal blood flow and  $\uparrow$  Potential for arrhythmias

**Respiratory System (RS)** - Activates the carotid bodies and may decrease the ventilatory response to hypoxia.

### Central Nervous System (CNS)

- Dopamine is a central neurotransmitter involved in the modulation of movement
- Exogenous dopamine does not cross the blood-brain barrier, except in its levorotatory form
- Causes marked nausea due to a direct action on the chemosensitive trigger zone (which lies outside the BBB)
- May cause increased intraocular pressure and decreased growth hormone secretion in critically ill patients
- **Metabolism** Metabolized in the plasma, liver, and kidneys by monoamine oxidase and catechol-o-methyltransferase to homovanillic acid and 3,4-dihydroxyphenylacetic acid

- 25 % of an administered dose is converted to noradrenaline within adrenergic nerve terminals
- Excretion mainly in the urine as homovanillic acid and its sulfate and glucuronide derivatives.
- The clearance is 234–330 l/hour, and the elimination half-life is 2 minutes

### Administration

- Solution with concentration >3.2 mg/ml should be given by central vein
- Incompatible with alkaline solutions, e.g. sodium bicarbonate, furosemide, phenytoin
- Discard solution if cloudy, discoloured, or >24 hours old

### Uses

- Low cardiac output
- Septic shock
- Treatment of bradycardia

### Contraindications & cautions

- Inadequately fluid resuscitated
- Pheochromocytoma
- Tachyarrhythmias or VF
- Patients on MAOI (reduce dose by one-tenth of usual dose)
- Peripheral vascular disease

**Adverse effects-** Ectopic beats, tachycardia, angina, gut ischaemia

### Dobutamine

- A synthetic isoprenaline derivative
- Predominant  $\beta$  1 effect- increase heart rate and force of contraction
- Infusion rate of 2-20  $\mu$ g/kg/min doesn't produce significant tachycardia except in severe CHF.
- Also acts directly on catecholamine receptors to activate adenylate cyclase
- Mild  $\beta$  2 and  $\alpha$  1 effects- Decreases peripheral and pulmonary vascular resistance
- May cause an increase in systolic BP because of the augmented cardiac output
- Increased myocardial perfusion
- Decreases left ventricular end-diastolic pressure (LVEDP) & SVR- increase in the cardiac index in patients with severe congestive cardiac failure.
- Has no specific effects on renal or splanchnic blood flow, but may increase renal blood flow due to increased cardiac output.
- Dobutamine enhances natural killer cell activity
- Decreases blood glucose and increases free fatty acid concentration
- Prolonged treatment with Dobutamine causes downregulation of  $\beta$  receptors, tolerance after 3 days



**Kinetics-** half-life 2 minutes, The VD is 0.2 l/kg, metabolism by COMT

**Preparation-** 250 mg made up to 50 ml glucose 5% or sodium chloride 0.9% (5000 µg/ml)

### Uses

- To provide positive inotropic support in patients with a low cardiac output, secondary to: myocardial infarction, cardiac surgery, cardiomyopathy, cardiac failures, positive end-expiratory pressure ventilation- Dose range is 0.5–40 µ/kg/minute; the drug acts within 1–2 minutes
- Cardiac stress testing

### Contraindications & cautions

- Cardiac outflow obstruction, e.g. cardiac tamponade or aortic stenosis
- Hypovolemia
- β-Blockers (may cause dobutamine to be less effective)

Adverse effects- Dysrhythmias, excessive tachycardia and hypertension, fatigue, nervousness, headache, chest pain, allergy

## Noradrenaline

- Directly and indirectly, acting sympathomimetic amine

### Mechanism of action

- The α 1 effect predominates over its β 1 effect, raising the BP by increasing the SVR
- Reflex vagal stimulation leads to a compensatory bradycardia
- Produces coronary vasodilatation, leading to a marked increase in coronary blood flow
- Reduces splanchnic, renal, hepatic and muscle blood flow
- But in septic shock, noradrenaline may increase renal blood flow and enhance urine production by increasing perfusion pressure
- May decrease insulin secretion, leading to hyperglycaemia

### Kinetics-

- VD is 0.09–0.4 l/kg

**Metabolism-** by two pathways: a) oxidative deamination to the aldehyde by mitochondrial monoamine oxidase (in the liver, brain, and kidney) b) methylation by cytoplasmic catechol-o-methyl transferase (COMT) to normetanephrine

- The predominant metabolite appearing in the urine is 3-methoxy, 4-hydroxymandelic acid (vanillylmandelic acid, VMA)
- Clearance is 27.9–100 ml/minute/kg
- Half-life is 0.57–2.4 minute

### Uses

- Septic shock

- With low SVR
- Refractory hypotension
- Usual dose range: 0.01–0.4 µg/kg/min IV infusion via a central

#### How not to use noradrenaline?

In the absence of haemodynamic monitoring

Avoid using through a peripheral vein (risk of extravasation)

Do not connect to CVP lumen used for monitoring pressure (may get flushed), connect to another limb of triple lumens

- **Adverse effects:** Bradycardia, hypertension, arrhythmias, myocardial ischaemia

#### Cautions

- Halothane anaesthesia- the risk of serious cardiac dysrhythmias
- If coadministered with MAO Inhibitors or tricyclic antidepressants, serious hypertensive episodes may be precipitated

### Ephedrine

- Indirect acting synthetic non-catecholamine.
- **Similarity with Epinephrine:**  
↑ BP, HR, Contractility & CO and is a Bronchodilator.
- **Differences from Epinephrine:**  
Longer duration of action, much less potent, Indirect & direct actions & Stimulates CNS
- Because of β<sub>1</sub> stimulating action used in moderate hypotension especially associated with bradycardia (e.g - during regional anaesthesia).
- Does not decrease uterine blood flow therefore preferred? Vasopressor for obstetric uses.
- **Dose:** Bolus(es) of 2.5-10 mg I.V.
- Tachyphylaxis can occur.
- Comes in an ampoule containing 30mg/ml to be diluted to 5mg/ml solution.

### Mephentermine

- Synthetic non-catecholamine.
- Directly by activating α and β adrenergic receptors and indirectly by releasing norepinephrine.
- Increases cardiac output, systolic and diastolic BP.
- Crosses BBB can cause excitatory effects
- Used to treat/prevent hypotension due to spinal/ epidural/ regional anaesthesia and other hypotensive states.
- **Dose:** 3- 6 mg I.V bolus.
- Comes in a vial containing 30 mg/ml, to be diluted to 3/5 mg/ml solution.

## Phenylephrine

- Synthetic non-catecholamine.
- Selective  $\alpha_1$  agonist. The drug does not affect  $\beta$ -adrenoceptors
- Causes peripheral vasoconstriction with rise in SVR & arterial BP.
- **Uses:** Hypotension accompanying Spinal anaesthesia (vasodilatation) in boluses of 50-100  $\mu\text{g}$  IV.
- Infusion dose for hypotension- 0.1-2mcg/kg/min
- Can cause reflex bradycardia.
- Tachyphylaxis can occur.
- Supplied in one ml ampoule containing 10mg (To be diluted to a 50/100 mcg/ml solution).
- Should be used with caution. (**appropriate dilution is a must before using the drug**)

# 45

## Respiratory Drugs

### INTRODUCTION

- It is imperative that Anaesthesiologists are aware about the common drugs used to treat respiratory acute conditions especially the ones which will be required in emergency use.
- Bronchodilators are important group of these drugs.

### LEARNING OBJECTIVES

- After going through this module, one should be able to describe the:

Learning Objective	Knowledge	Skills
<ul style="list-style-type: none"><li>• Bronchodilator agents (General drug information, its preparation, Doses and administration, Indications and contraindications)</li></ul>	✓	✓ <ul style="list-style-type: none"><li>• During the posting observe, assist and then practice under supervision the use of appropriate bronchodilator agents whenever required</li><li>• Document their use in clinical logbook at appropriate place.</li></ul>

### BRONCHODILATORS:

- These drugs are used in patients with airway diseases (Obstructive airway disease) like COPD and Asthma
- They are commonly administered through inhalational route and their main action is to reverse the bronchoconstriction
- Main Categories of drug in this group are
  - **Beta-2 adrenergic agonist**
  - **Anticholinergic**
  - **Xanthine derivatives**
  - Corticosteroids (Inhaled or oral) – Not direct bronchodilator but reduced inflammation, airway reactivity and airway oedema
- Other drugs which can be considered in the acute bronchospasm episodes other than the above except Theophylline (Xanthine derivatives) are

- Nebulised Adrenaline
- Ketamine
- Inhalational Anaesthetic agents
- Heliox
- Lets learn about main group of drugs in the subsequent action, others are covered in other sections where appropriate.

### **Beta-2 adrenergic agonists:**

- Short (Intermediate) acting: Salbutamol
- Long acting: Salmeterol, Formoterol

### **Pharmacokinetics:**

- Short acting drugs act fast and their duration of action is also small say around 3 to 4 hours.
- Long acting drugs (LABA) effects last for almost close to 10 to 12 hours

### **Pharmacodynamics**

- The drugs act on the beta 2 adrenergic receptors in the respiratory system and produces broncho-dilatation
- Additionally it is also believed to cause
  - Efficiency improvement in muco-ciliary clearance
  - Inhibition of cholinergic transmission
- Doesn't reduce inflammation and thus cannot be used as replacement for steroids where inflammation is also a significant concern.

### **Dosage and administration:**

- Dose depends upon the condition of the patients (Prevention of episode as maintaining or treating an acute attack) as well as the route and preparation. Most common route is the inhalational route for beta 2 adrenergic agonist.
- Salbutamol in a metered dose inhaler commonly comes in strength of 100microgram / puff. 2 to 6 Puffs might be needed daily in divided doses as per the condition. Maximum dose should not be exceeded to be more than 800 micrograms in Adults.
- Salbutamol is supplied as liquid drug for nebulisation use. It is generally supplied as 2.5mg per 5 ml (however individual brand preparation needs to be checked). It is used as 2.5mg nebulisation in adults and can be used up to 4 times a day. In Acute condition, it can be repeated immediately at least once if the bronchospasm is not relieved, while monitoring for adverse effects.
- Salmeterol comes as 50 microgram / puff and generally 2 puffs per day with a gap of 12 hours in between is recommended. This however has to be approved by the physician treating the condition
- For acute condition, Salbutamol inhalation ( either MDI or through nebulisation) remains a very good choice. Short acting like Salbutamol are good choice for rapid relief of symptoms in acute conditions, however long acting agents would be preferable for maintenance treatment

#### Disadvantages / side effects:

- Because of its effects on beta 2 adrenergic receptors which are widespread in the body, these agents do cause side effects
  - Tachycardia
  - Hyperglycaemia, Hypokalaemia (It is one of the treatments for hyperkalaemia)
  - Muscle tremors
  - Tolerance / desensitisation

#### Clinical indications and uses:

- COPD
- Asthma
- Other obstructive lung diseases

#### Contraindications / Precautions:

- Use carefully in patients with Cardiovascular disease where significant tachycardia will cause deleterious effect
- Watchful in patients with hypokalaemia.

#### Anticholinergics:

- Though less effective than beta 2 adrenergic agonist, they also form mainstay of treatment in the COPD and asthma

#### Pharmacokinetics:

- Short acting agents – Ipratropium bromide will show its peak effect within 30 to 60 minutes and the effects will last between 4 to 6 hours
- Newer compounds i.e. long acting compounds like Tiotropium have significant duration of action (almost 24 hours) and are therefore prescribed once a day.

#### Pharmacodynamics:

- Antagonists of muscarinic receptors.
- They inhibit the cholinergic nerve reflexes

#### Dosage and administration:

- Ipratropium is available as solution for nebulisation, as metered dose inhaler or as nasal spray.
- Metered dose inhaler comes with 17microgram per puff actuation. The recommended dosage in adult is 2 puffs every 4 to 6 hourly. At times initial 4 puffs may be needed for appropriate effect in certain group of patients.
- The Maximum allowed dosage in 24 hours is around 12 puffs as cleared by the FDA. A puff once inhaled, the dose need not be repeated for 4 to 6 hours.
- Nebulisation solution comes as 500 micrograms in 2.5 ml (Need to always check with the available brand the actual preparation).

- 500 microgram nebulisation 3 to 4 times per day is the recommended nebulisation dose.

#### Disadvantages:

- Inhaled drugs are very less absorbed and therefore carry minimal side effects with them
- If absorbed directly in the eye, in susceptible population they might lead to glaucoma so care needs to be taken

#### Indications/use:

- COPD maintenance and acute exacerbations
- Asthma & Other obstructive lung diseases

#### Xanthine derivatives:

- Theophylline: - Though has been used for long time in the treatment of obstructive lung diseases spanning almost 5 to 6 decades of use however theophylline has a narrow therapeutic index.
- Doxofylline is an effective bronchodilator and displays better safety profile though not easily available.
- Intravenous aminophylline was a commonly used drugs in the ICUs and emergency scenarios previously for acute bronchospasm episodes, however its use has decreased considerably now due to availability of better drugs like inhaled bronchodilators (predominantly the beta 2 adrenergic agonist and the anticholinergic also)

Theophylline:

#### Pharmacokinetics:

- Predominantly eliminated by hepatic cytochrome p450 system in liver.

#### Pharmacodynamics:

- Bronchodilator (mild to moderate at the best)
- Immuno-modulatory effect
- Anti-inflammatory effect
- Inhibition of phosphodiesterases

#### Dose and administration:

- Theophylline has been used more commonly in COPD maintenance where despite other uses, the patient is still symptomatic. Its role in Asthma chronic treatment is questionable.
- Guidelines don't recommend its use in asthma exacerbations.
- Even in patients with Acute COPD exacerbations, IV theophylline is not recommended by the guidelines due to significant side effects.
- Oral dose is around 300mg used in divided doses every 8 to 12th hourly

#### Side-effects

- Theophylline has a narrow therapeutic window and its frequent interaction with other drugs has



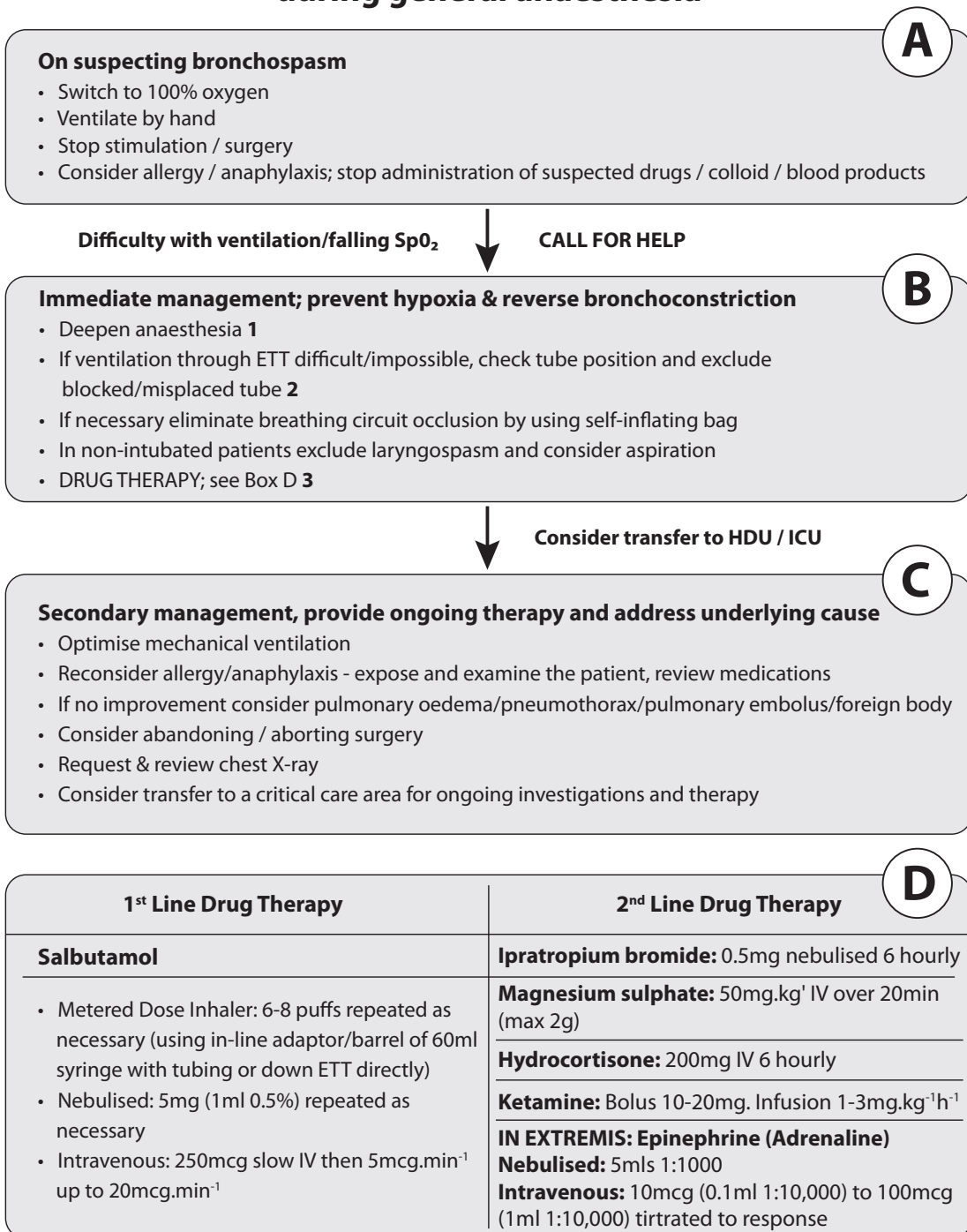
led to decreased usage of the drug (especially in the emergencies)

- Nausea, Vomiting
- Gastro-oesophageal reflux
- Light headedness, dizziness

**Contra-Indication / precautionary use:**

- Hypersensitivity
- Cardiac disease – exacerbate arrhythmias
- Liver diseases – dangerous drug levels may reach in absence / of decreased metabolism
- Peptic ulcer diseases

**Management of patient with suspected bronchospasm during general anaesthesia**



**Follow up.** If a serious allergic/anaphylactic reaction was suspected or identified the anaesthetist must ensure the patient is referred to a specialist allergy/immunology centre for further investigation. The patient, surgeon and general practitioner should also be informed.

Update in Anaesthesia. [www.anaesthesiologists.org](http://www.anaesthesiologists.org) -- WFSA

**Follow up.** If a serious allergic/anaphylactic reaction was suspected or identified the anaesthetist must ensure the patient is referred to a specialist allergy/immunology centre for further investigation. The patient, surgeon and general practitioner should also be informed.

Update in Anaesthesia. [www.anaesthesiologists.org](http://www.anaesthesiologists.org) -- WFSA

### KEY LEARNING POINTS:

- Obstetric patients with COPD / Asthma may present for emergency caesarean sections – either in optimised or un-optimised conditions
- Inhalational agents like Beta 2 adrenergic agonists and / or Anticholinergic drugs remains the drug of choice for treatment.
- Short acting beta 2 adrenergic agents like salbutamol and short acting anticholinergic like Ipratropium bromide may be used in emergencies
- Theophylline secondary to narrow therapeutic index and increased chances of adverse events is no longer recommended by the guidelines in the acute exacerbations of COPD or Asthma conditions

### CHECK YOUR PROGRESS

Q1. What are bronchodilators, classify them with examples

Q2. Write short note on Salbutamol

Q3. Write short note on Ipratropium

---

# Week 12 - Module

## Referral, Transportation & Communication skills



# 46

## Communication skills

---

### INTRODUCTION

- Health care providers have a belief that being healthcare providers automatically transfers the virtue of being a good communicator, however, it is not so and it is not uncommon to observe that even the best of clinicians at times are poor communicators.
- A complete healthcare picture will entail not only good diagnosis and clinical management of the case but will also require a good healthcare provider – patient and relative’s effective communication to have a more satisfactory treatment experience.
- It is equally important that the communication amongst various health care providers directly or indirectly related to the patient care is also of utmost standard level which helps further to improve this aspect.
- More often than not, the healthcare provider has the tendency to believe that he or she has communicated the things in the best possible way and the person to whom it has been explained has interpreted in a wrong way or didn’t have the ability to understand. Only with an open mind and an acceptance to the fact that ‘communication is science and art’ and needs to be learned will the healthcare provider evolve in this aspect and continue to grow.
- In obstetrics practice, where two lives are at stake i.e. the mother and baby the communication skills become further more important.
- Though want a formal subject either for teaching or for evaluation in medical curriculum, several universities have slowly started introducing communication skills for the medical students as a concept and quite few universities keep albeit low but a definitive percentage of marks for evaluation in the final university exams. Communication skills and courses are also introduced for the university medical college teachers.
- It is imperative that the caregivers learn this and gradually evolve in this aspect as this will help majorly in repairing the deteriorating doctor – patient relationship. This will help the patient have more satisfaction being experienced in the healthcare delivery system, as well as will help healthcare providers ultimately have a more satisfactory overall experiencing in delivering healthcare to the society.
- There are various models, protocols and literature coming up on how to effectively communicate, however none can be said as the pen-ultimate or having extreme supremacy over the others. These things will always continue to evolve as this is directly linked to the socio-cultural aspect of the society where we live in which itself will continue to evolve.

### LEARNING OBJECTIVES

- After going through this module, you should be able to describe the:

Learning Objective	Knowledge	Skills
<ul style="list-style-type: none"> <li>Importance of learning appropriate communication skills in different situations like breaking bad news, counselling about critical condition of the patient. Learn the aspect about environment, etiquettes, body language of communication skills also.</li> </ul>	✓	<ul style="list-style-type: none"> <li>Observe, learn under supervision appropriate learning skills and practice them.</li> <li>Use simulation classroom techniques (role-plays) to learn them.</li> </ul>
<ul style="list-style-type: none"> <li>Know about the WHO recommendations on effective communication between maternity care providers and women in labour</li> </ul>	✓	

## WHO RECOMMENDATIONS ON EFFECTIVE COMMUNICATION BETWEEN MATERNITY CARE PROVIDERS AND WOMEN IN LABOUR

- Below is the “WHO documents reproduction” on effective communication in short.
- This gives an overall background on the basis of which effective communication skills can be planned.

### Recommendation

- Effective communication between maternity care providers and women in labour, using simple and culturally acceptable methods, is recommended.

### Remarks

- In the absence of a standardized definition of “effective communication”, the GDG agreed that effective communication between maternity care staff and women during labour and childbirth should include the following, as a minimum.
- Introducing themselves to the woman and her companion and addressing the woman by her name;
- Offering the woman and her family the information they need in a clear and concise manner (in the language spoken by the woman and her family), avoiding medical jargon, and using pictorial and graphic materials when needed to communicate processes or procedures;
- Respecting and responding to the woman’s needs, preferences and questions with a positive attitude;
- Supporting the woman’s emotional needs with empathy and compassion, through encouragement, praise, reassurance and active listening;
- Supporting the woman to understand that she has a choice, and ensuring that her choices are supported;
- Ensuring that procedures are explained to the woman, and that verbal and, when appropriate, written informed consent for pelvic examinations and other procedures is obtained from the

woman;

- Encouraging the woman to express her needs and preferences, and regularly updating her and her family about what is happening, and asking if they have any questions;
- Ensuring that privacy and confidentiality is maintained at all times;
- Ensuring that the woman is aware of available mechanisms for addressing complaints;
- Interacting with the woman's companion of choice to provide clear explanations on how the woman can be well supported during labour and childbirth.
- Health systems should ensure that maternity care staff are trained to national standards for competency in interpersonal communication and counselling skills.

## **BREAKING BAD NEWS, ESTABLISHING GOALS OF CARE IN CRITICALLY ILL PATIENTS:**

- Six Step Protocol for Delivering Bad News to the Patients:
- Use the ACRONYM: SPIKES
- Though used for breaking bad news, it may well form a basis of communication to almost all patients who have the potential to be critical.

### **SPIKE PROTOCOL:**

#### **STEP 1: Setting**

- Setting up the interview.
- Create privacy for the counsellor and patient and closed relatives
- Involve only the significant members from the patient's family
- Try to establish connections with them

#### **STEP 2: Perception.**

- Assessing the patient's Perception.
- Generally, we should use open ended questions – e.g. ask them their perception of what is going on with the patient's clinical condition?

#### **STEP 3: Invitation.**

- Obtaining the patient's Invitation.
- The clinician or the counsellor should seek from the patient and relatives if they are ready to learn more about the patient's condition at the stage so that further discussion can be engaged.
- e.g. Clinical can ask "Is it ok to share with you the results of the patient's blood reports now"?

#### **STEP 4: Knowledge**

- Giving Knowledge and information to the patient.
- Medical Jargons should be avoided



- Use simple language which the patient's and relatives can understand
- A good eye contact with them is good

### **STEP 5: Empathy**

- Addressing the patient's Emotion.
- One should be empathetic towards the patient and family.
- It is hard time, give some time for the information to be processed.
- Tears or silence will be at times natural response, do not discourage it immediately.
- One can provide support to them.

### **STEP 6: Strategy and Summary.**

- Towards the end, it is essential to summarise the thought process.
- This will help formulate the strategy ahead as how to proceed further?

### **COMMUNICATING WITH THE ATTENDANTS:**

- This is required if a doctor is treating an indoor patient.
- Attendants are apprehensive and at times full of doubts and queries.
- This is more important when the patient is critically ill or admitted in ICU.

### **TIPS TO COMMUNICATE - A BRIEF SUMMARY:**

- Conduct conferences once or twice a day.
- Appreciate the efforts made by them.
- Satisfy their queries by giving better references.
- Explain the dynamic nature of the disease especially in a critically ill patient.
- Second opinion to be sought proactively.
- Convince that all efforts are made to bring situation under control or will be controlled.

### **COMMUNICATING WITH COLLEAGUES:**

- Never talk low about your colleagues.
- Greatest courtesy should be displayed for all staffs.
- Lead by setting examples.
- Audit and regular feedback improves professional practice.
- Have closed loop communication in critical settings for e.g. like CPR is going on – It helps to minimise errors.



## KEY LEARNING POINTS:

- Good communication skills among the doctors is crucial in building a trustworthy doctor patient relationship.
- Helps in therapeutic success by providing holistic care.
- There is necessity of formal training in this.
- WHO recommendations for effective communication between the maternity care providers and the patient-family is a useful document to understand the pearls

## CHECK YOUR PROGRESS:

Q1. What is the importance of having a good communication skill in medical practice? How can you summarise current condition in this aspect?

Q2. What are the WHO recommendations on effective communication between maternity care providers and women in labour – write your understanding on this?

Q3. What is spike protocol? Write short note.

### References:

WHO Reproductive Health Library. WHO recommendation on effective communication between maternity care providers and women in labour (February 2018). The WHO Reproductive Health Library; Geneva: World Health Organization.

# 47 & 48

## Referral and Transport of critically ill patients

### INTRODUCTION

- Majority of the women in India now have access to institutional delivery where skilled manpower help and resuscitation equipment would be available ranging from basic units like PHCs, first referral units, sub district hospitals, District hospitals and dedicated maternal hospitals and tertiary medical college university teaching hospitals.
- There will be certain obstetric cases where if the complications occur, they will have to be referred to higher centre for needful emergency obstetric care. This will need transporting critically ill obstetric patient with a potential for adverse maternal and neonatal outcome.
- In one of the older studies, it was found that significant number of complications occurred for mothers either at home or while on the route, while being transported.
- India has developed a vast network of ambulance services for the patients and is continuously upgrading these services, however it is equally important for the healthcare workers to understand that transporting any critically ill patient ,especially obstetric patient is a science with specific protocols and training required. It involves a good team work for optimal outcome.

### LEARNING OBJECTIVES

- After going through this module, one should be able to describe the:

Learning Objective	Knowledge	Skills
<ul style="list-style-type: none"><li>• Understand the transport of critically ill patient (obstetric especially)</li><li>• Learn the principles, indications, precautions and preparation required for the same.</li></ul>	✓	<ul style="list-style-type: none"><li>✓</li><li>• During the posting observe, assist transportation of any critically ill patient at least within the intrahospital facility.</li><li>• Document the same in logbook.</li></ul>

### GENERAL CONSIDERATION FOR TRANSPORTING A CRITICALLY ILL PATIENT:

- Transport of a patient can be classified into
  - Prehospital transport: e.g. site of accident/house to hospital
  - Intrahospital transport: e.g. shifting a critically ill patient for urgent CT scan
  - Inter-hospital transport: Shifting a critically ill patient from a basic unit to higher referral

centre

- Various societies have formed guidelines on transport of critically ill patients
- A consideration about risk and advantages of transferring a critically ill patient should always be done whenever planning the transport. The risk is of creating instability and adverse events during the transfer vs the advantage of diagnosing and treating potentially reversible condition (especially life threatening) well in time to decrease the morbidity and mortality
- The ultimate goal while considering the above is to improve the patient's outcome.
- It is important to understand the Adverse events associated with this as well as preparations and planning required for transporting a critically ill patient

## ADVERSE EVENT:

- Adverse events during transport of a patient can be
  - Minor or
    - Agitation, vomiting, line incidents, incident with pumps like battery low
  - Major (life threatening)
    - If minor incident in long term has tendency to become life threatening
    - Desaturation
    - Hypotension
    - Endotracheal tube self extubation
    - Precious lines / catheters dislodgement
- The incidence ranges depending upon the team, type of patient anywhere between 5 to 7% in various literature.
- Adverse events can be attributed to

### Equipment related factors

- Malfunctioning of the equipment
- Low battery of critically important equipment
- Backup equipment not available

### Staff related factors

- Poorly trained staff without knowledge of the handling of such emergencies or equipment
- Poorly motivated staff
- Individual staff good but a poor team work

### Patient related factors

- A critically ill patient with higher severity score of illness
- Obese patients, extremes of age, pregnant patients are vulnerable population

## ACTUAL PROCESS OF TRANSPORT:

- Can be divided into 3 phases
  1. Preparatory phase
  2. Actual Transport
  3. Stabilisation after transport in the final destination unit

### 1. Preparatory phase

Patients who need to be transferred to an ICU within the same hospital or in another hospital's ICU need a proper transport system in place. In ideal settings a transport ventilator should be available. However, if not available, at least a manual bag resuscitator and tube ventilation with PEEP valve and oxygen cylinder is needed for transporting a patient from HDU to ICU.

Such transfer will require the following systems to work but not limited to these-

After initial stabilization of the physiological parameters to the best possible over a short period of time, the benefits of making an early transfer of the patient to a definitive care facility must be weighed against the risk of holding the patient back to the current facility. This can be considered even with the ongoing resuscitation and stabilization during the transport. The transport capabilities in terms of infrastructure (advanced ambulance), manpower (trained paramedics) needs to be weighed in while making above decisions.

- 4 components (4Ps) preparation
  - Paraphernalia: Equipment and drugs

Equipment:

- What equipment is required? (Monitoring equipment should measure non-invasive parameters like SpO<sub>2</sub>, NIBP, ECG and preferably EtCO<sub>2</sub>. Along with defibrillator, resuscitative equipment should contain oxygen source, oxygen delivery devices including AMBU bag with O<sub>2</sub> reservoir, transport ventilator, fluid resuscitation devices like syringe pump, difficult airway device cart including laryngoscope, bougie, endo tracheal tube, supraglottic airway, oropharyngeal and nasopharyngeal airway, adhesive tape to secure airway device etc)
- Does it work?
- Backup for equipment
- How does it work?

Drugs:

- What drugs? (emergency drug set and specific drug set for the given patient)

Emergency lifesaving drugs like following but not limited to-

- ✓ **Cardiac Drugs:** Adrenaline, Nor Adrenaline, Dobutamine, Atropine, Amiodarone, Xylocard, Nitroglycerine injections.
- ✓ **Others:** - Calcium gluconate, Soda bicarbonate, Potassium chloride, 25% dextrose, Bronchodilators, Hydrocortisone.
- ✓ **Sedative** – Neuromuscular – Anti-convulsants: Midazolam, Propofol, Succinylcholine, Atracurium, fosphenytoin / phenytoin.
- Drugs, whether should be standby or drawn and ready in syringes?
- Stocking of drugs for the anticipated period of transport.

- Patient
  - History and brief examination
  - ABCD noted
  - Tubes and catheters
  - Restrain and Comfort
  - Stability of the patient (best possible before shifting itself)
- Personnel (staff)
  - Depending upon the severity of the disease and available of human resources
  - If critically ill patient? Preferably 2 trained personnel in emergency management as emergency life support – most commonly transferring personnel are nurses and paramedic technicians
  - A well trained team can decrease the adverse events significantly
- Plan
  - Communication to the receiving team well in advance about the transfer, condition of the patient and expected timing.
  - Anticipation of problems while en-route and planning to counteract them helps significantly.
  - Documentation of the above process is equally important. For medico legal purposes as well as for the auditing and quality improvement. Should include indications, consent, pre, intra and post transport vitals recording, handover notes.

## 2. Actual transport:

- Distance
- Method of transport
- Conditions of Traffic, weather, Lifts etc...
- Minimise the time out of the ICU while shifting the patient. All preparations should be done well in advance so that once patient is moved out of ICU, he or she can go straight to ambulance and destination rather than to wait in corridors
- Clearing the traffic – on roads as well as hospital corridors equally important

## 3. Stabilisation after shifting to final destination

- In sick patients, stabilization is done mostly in the ICU.
- It is important to remember that the patients are always at the risk of adverse events in the immediate hours after transport
- Proper handing over to ICU. It is worth having a transfer protocol so that things are not missed while giving handover.

## OBSTETRIC PATIENTS TRANSFER IN BRIEF:

- Obstetric patients especially ANC patients have two lives at stake
- Above principles of transporting critically ill patients well applies to these patients also albeit

little modifications

**Can be as Two scenarios:**

- Transport within hospital settings.
- Transporting to a first referral unit.

**TRANSPORT WITHIN HOSPITAL SETTINGS:**

- Transporting within hospital settings include shifting a critically ill mother to ICUs, from labour ward to operation theatre.

**Goals:**

- Maintain maternal cardiac output.
- Maintain maternal oxygenation.
- Take care of the lines/drains/tubes.
- Foetal heart rate to be noted and maintained while shifting the mother.

**Maintain Maternal Cardiac Output:**

- Shift in Left lateral position.
- IV fluid should be continued.
- Continue inotropic or vasopressor agents.
- Monitor patient's ECG, HR and BP.
- Keep emergency drugs and airway equipment in the shifting trolley.

**Maintain Maternal Oxygenation:**

- Shift in left lateral position.
- Oxygen supplementation by mask.
- Positive pressure ventilation with Bains circuit with 100% O<sub>2</sub> in case the mother is intubated with ETT (Check the O<sub>2</sub> content of the cylinder before shifting).
- Monitor the SPO<sub>2</sub> while shifting.

**TRANSPORTING TO A FIRST REFERRAL UNIT:**

- This means shifting the patient to a higher center for further management.
- Same goals as for transport inside hospital setting.
- In addition, the attending physician should be aware of the setting inside the ambulance.
- Defibrillator, O<sub>2</sub> cylinder, emergency drugs and fluids, airway equipment, portable ventilator, Bag-Oxygen or T-piece or Bain Circuit assembly and monitor for ECG, BP, SpO<sub>2</sub> should be checked and made available.
- In addition to these, try to contact the referral unit in advance and inform about the mother's condition so that the emergency team can be kept ready for immediate assessment and treatment.

## KEY LEARNING POINTS:

- Transporting any critically ill patient is a responsible and tough job and it needs training (simulation based at least).
- Transporting the critically ill patients should balance the risk associated while transferring against the potential advantage of diagnosing and managing a life threatening complication.
- Transfer can be done either prehospital, intrahospital or inter-hospital
- Transferring a patient should be done by giving careful consideration to preparation phase, actual transport phase and post transfer Stabilisation phase.

## CHECK YOUR PROGRESS:

Q1. Write short note, with examples, listing types of transport and advantages and risks of transferring a critically ill patient.

Q2. Write essay about Transferring a critically ill patient.

Q3. Write short note on transferring an obstetric critically ill patient.



# 49

## Fetal Distress: Anesthesiologist role

### INTRODUCTION

- Foetal reaction to asphyxia also known by non-reassuring foetal status.
- Asphyxia occurs commonly due to insufficiency of uterine/umbilical blood flow or occasionally due to decreased uterine arterial oxygenation.
- It is one of the common indications for urgent caesarean section and timely intervention is important.
- There are series of things which can be done while the patient is being wheeled in operation theatre, till anaesthesia is given to deliver the baby by caesarean section.

### LEARNING OBJECTIVES

- After going through this module, one should be able to describe the:

Learning Objective	Knowledge	Skills
• To understand foetal distress	✓	✓ • Assist the sections coming in emergency for foetal distress. • Assess foetal distress, do intrauterine resuscitation, and give anaesthesia for foetal distress under supervision
• Intrauterine foetal resuscitation	✓	
• Anaesthesia and management for foetal distress	✓	

### HOW TO IDENTIFY FOETAL DISTRESS?

Foetal Heart rate variability is the key !

- Presence of normal foetal heart rate variability indicates normal foetal CNS integrity (including adequate oxygenation).
- Abnormal or loss of foetal heart rate variability is a sign of foetal asphyxia.
- Early/late/variable deceleration of foetal heart rate and prolonged foetal bradycardia with respect to uterine contractions should be promptly attended

### MANAGEMENT OF FOETAL DISTRESS:

Foetal Distress is primarily a decision made by the obstetrician time and Proceeding with

Caesarean section is there decision. Anesthesiologists and obstetricians should work together to optimise the outcomes in a given patient, however the decision for diagnosing a foetal distress and need for intervention in terms of LSCS is primarily an Obstetricians decision.

## **INTRAUTERINE FOETAL RESUSCITATION:**

### **Goals of management:**

1. Identify the cause and prompt treatment.
2. Maintain maternal cardiac output (BP).
3. Increase maternal arterial oxygen content (SPO<sub>2</sub>).

### **Management includes:**

- Left lateral position which relieves aorto-caval compression or optimizing position to relieve umbilical cord compression.
- Oxygen supplementation to improve maternal oxygen content.
- Maintain maternal and foetal circulation - perfusion.
- Rapid IV crystalloid bolus (non dextrose based )
- If hypotension, use phenylephrine or ephedrine or mephentermine as available
- Reduction of Uterine hyperactivity (Stop oxytocin or administer terbutaline).
- Delivery of the fetus at the earliest feasible option.

## **DELIVERY OF THE FETUS:**

- Persistent signs of asphyxia not responding to intrauterine foetal measures necessitates immediate delivery of the fetus.
- Quick maternal assessment in the preoperative area to look for maternal comorbidities, past medical or surgical history and to confirm NPO.
- Examination of CVS, RS and airway assessment is of utmost importance which decides the plan of anaesthesia.
- Shift the mother to operation theatre in left lateral position with oxygen supplementation, IV fluids. Administer aspiration prophylaxis.

## **ANAESTHESIA FOR CESAREAN SECTION (LSCS): NEURAXIAL (COMMONLY SPINAL) OR GENERAL ANAESTHESIA.**

### **Spinal Anaesthesia for Emergency LSCS:**

1. Preparation of operation theatre with emergency drugs, airway equipment, defibrillator and suction apparatus (two) should be kept ready.
2. Left lateral position, secure two wide bore IV cannula.
3. Preloading or co-loading with crystalloids
4. Perform Rapid Sequence Spinal

### Rapid Sequence Spinal:

- Under aseptic precautions, 23/24/25 G spinal needle (Quinke/Whitacre) should be used.
- After loss of resistance, CSF flow should be appreciated.
- After confirming good CSF flow, administer 1.8 to 2 ml of 0.5% Bupivacaine into the subarachnoid space.
- While making the patient supine, apply a wedge under the right buttock to relieve aorto-caval compression. Check the spinal sensory and motor level, ECG, BP, SpO<sub>2</sub>. Keep oxygen flowing through face mask at 5 litres per minute.
- Surgical incision can be made once the spinal sensory level reaches T4 dermatome. Administer oxytocin or other uterotonics once baby is delivered.
- Foetal assessment and Neonatal resuscitation if required.
- Always stay with the patient during LSCS. If required, keep on talking with the patient to relieve her apprehension and to check the higher spread of spinal anaesthesia.

### GENERAL ANAESTHESIA:

1. Preparation of operation theatre with emergency drugs, airway equipment, defibrillator and suction apparatus (two) should be kept ready.
2. Secure two wide bore IV cannula.
3. Preloading or co-loading with crystalloids.
4. Surgical part should be painted and draped.
5. Perform Rapid sequence induction (RSI) with cricoid pressure.

### RSI with Cricoid Pressure:

- 6,6.5 mm ETT, Bougie and 3, 4 size LMA along with other airway equipment should be made available.
- IV induction with Inj. Thiopentone 5mg/kg or Propofol 2mg/kg, Inj. Succinylcholine 1.5 mg/kg.
- Cricoid pressure to be applied (Sellick's maneuver).
- After 60 seconds, perform laryngoscopy and intubation. Confirm ETT position by 5-point auscultation and ETCO<sub>2</sub> tracing.
- Instruct to start cesarean section, if everything OK.

### Intraoperative Management:

- Maintenance anaesthesia by inhalational agents, muscle relaxants and analgesia.
- Monitor vitals (ECG, BP, SpO<sub>2</sub>) and urine output.
- Oxytocin infusion (10 to 20 IU in 500 ml NS/RL given at 100ml/hour) to be started once baby is delivered. If Twin pregnancy, wait till the delivery of other baby.
- Foetal assessment and neonatal resuscitation if required.
- Extubation once the surgery ends and the patient is awake, obeying commands with adequate ventilation.
- Shift both the mother and the fetus to Post Anaesthesia Care Unit (PACU) for observation.

## KEY LEARNING POINTS:

- Anaesthesiologist play a key role in helping deliver a healthy neonate especially when there is a non-reassuring foetal status/foetal distress by doing series of things in coordinated and timely manner preoperatively & intraoperatively when baby delivery is planned by caesarean section by the attending obstetrician.
- It is imperative to identify foetal distress and initiate intrauterine foetal resuscitation while foetal delivery is expeditiously being planned
- Intrauterine foetal resuscitation constitutes of measures to improve maternal foetal circulation and thereby allowing adequate oxygenation to foetus
- Anaesthesiologist should be well versed with the rapid sequence spinal and rapid sequence induction with cricoid pressure (general anaesthesia).

## CHECK YOUR PROGRESS

Q1. How does one identify foetal distress?

Q2. What is intrauterine foetal resuscitation ?

Q3. Enlist the steps taken during employing spinal anaesthesia technique for caesarean section for foetal distress . Describe in short rapid sequence spinal anaesthesia>

### References:

Chestnuts textbook of obstetric anaesthesia

# 50

## Infection control practices in operation theatre

---

### INTRODUCTION

Health care facilities are prone to be a source for iatrogenic infections for their patients either through their compromised protocol, practice of service providers, through patient's attendants, or beneficiaries using health facilities.

The number of procedures undertaken in an operating theatre per 100,000 population per year in India is 954<sup>2</sup>. For a district with an average population of 20, 00,000, this amounts to 52 procedures per day (approximately). Each of these procedures involves contact by a medical device or surgical instrument with a patient's sterile tissue or mucous membranes. A major risk of all such procedures is the introduction of pathogenic microbes, which can lead to infection. In the developing world the health care associated infection rate is 25% or more i.e., 25 infections per 100 patient admissions<sup>3</sup>. So, in a district, approx. 13 patients are at the risk of acquiring hospital acquired infection per day.

An alarming rate of Hospital Acquired Infections (HAI) in Indian hospitals has highlighted the importance of disinfection, sterilization and infection control practices. Such practices are essential for ensuring that infectious pathogens are not transmitted to patients. So, in a hospital setup OTs and critical care areas are prone to infection if there are inadequate sterilisation, lack of adherence to infection control protocols like decontamination, hand washing, routine cleaning of various zone etc.,

Hence, controlling infections in OT becomes a priority for conducting safe operative procedure. It is therefore important that the staff working in OT should be proficient and skilled in taking all essential measures required for controlling infection. This also need adequate infrastructural support to maintain the desire flow of services. This has been explained in the chapter organizing OT.

### LEARNING OBJECTIVE

Here in this chapter infection prevention protocols, segregation and decontamination of equipment and linen, disposal of biomedical waste etc. have been explained. The chapter also explains various types of hand washing technique, wearing PPE etc.

To control infection, the following steps are necessary to be adhered to:

---

<sup>2</sup>The Lancet Commission on Global Surgery

<sup>3</sup>A guide to infection control in the hospital, International Society for infectious diseases

- A. Universal precaution
  - 1. Wash your hands/ Hand hygiene
  - 2. Use of personal protective equipment (PPE)
  - 3. Prevent injuries with sharps.
  - 4. Correctly process instruments / equipment & linen.
- B. Routine cleaning
  - 1. Maintain correct environmental cleanliness.
  - 2. Biomedical waste management
- C. Sterilization

### A. Universal Precautions for Infection Prevention

- Health care facilities are ideal settings for transmission of disease because:
- Invasive procedures can introduce microorganism into patient’s body parts.
- Service providers and other staff are constantly exposed to potentially infectious materials as part of their work.
- Many of the people seeking health care services are already sick and may be more susceptible to infection.
- Some of the people seeking services have infections that can be transmitted to others.
- Services are sometimes provided to many clients in a limited physical space, often during a short period of time.

### Standard/ Universal precautions:

Appropriate infection prevention practices help in preventing post-procedure infection, including surgical site infections and pelvic inflammatory disease (PID). This also helps in controlling and minimizing the spread of antibiotic-resistant microorganisms. Such measure also lowers the cost of health care services. Standard precautions are set of recommendations designed to help minimize the risk of exposure to infectious materials by both client and staff. Standard precautions should be followed with every client/beneficiary regardless of whether or not you think the client/ beneficiary might have an infection.

#### 1. Hand washing/ Hand hygiene

Indications for hand hygiene: 5 moments of hand wash (WHO 2009)



Sink and elbow tap is must for hand hygiene.

Three kinds of hand washing:

1. Routine hand washing with plain soap and running water
2. Surgical scrub
3. Surgical alcohol hand rub

### 1. Routine hand washing with plain soap and running water:

This is appropriate in most situations. Soaps containing 4% w/v chlorhexidine with detergent is used.

Duration of hand wash: 40-60 seconds

### 2. Surgical Scrub:

This is appropriate before invasive procedures (inserting central venous catheter; spinal tap, etc.) and before contact with clients at high risk of infection (new-borns, immunosuppressed clients etc.) and before surgical procedure. 4% w/v chlorhexidine / iodine based with detergent is used. Ideally, it should be performed before every procedure. In busy theatres if hands are not visibly dirty an alcohol hand rub may be used between cases. But surgical scrub must be performed after every four cases or 1 hour whichever is earlier, or if hands are visibly soiled.

### 3. Surgical alcohol hand rub:

This kill and inhibits microorganism but does not remove micro-organism. Using alcohol alone tends to dry the skin, it is best to use an alcohol hand rub solution containing 70% alcohol with emollients and moisturizer.

To use an alcohol hand rub solution: pour 3-5 ml of an alcohol hand rub solution into the palm of your hand and rub hands together until they dry (put a picture). Rub till the elbow. For details see below:

## 2. Personal protective equipment (PPE)

- Ensure choice of gown size is correct.
- Perform hand hygiene depending upon type of procedures / examination to be undertaken.
- Put on isolation gown. Tie all the ties on the gown. Assistance may be needed by other healthcare personnel.
- Facemask: Mask ties should be secured on crown of head (top tie) and base of neck (bottom tie). If mask has loops, hook them appropriately around your ears.
- Put on gloves. Gloves should cover the cuff (wrist) of gown.

### How to Take Off (Doff) protective Gear

More than one doffing method may be acceptable. Training and practice using your healthcare facility's procedure is critical. Below is one example of doffing.

Remove gloves. Ensure glove removal does not cause additional contamination of hands. Gloves can be removed using more than one technique (e.g., glove-in-glove or bird beak).

Remove gown. Untie all ties (or unsnap all buttons). Some gown ties can be broken rather than untied. Do so in gentle manner, avoiding a forceful movement. Reach up to the shoulders and carefully pull gown down and away from the body. Rolling the gown down is an acceptable approach. Dispose in trash receptacle.

Facemask: Carefully untie (or unhook from the ears) and pull away from face without touching the



front.

Perform hand hygiene after removing the respirator/face mask and before putting it on again if your workplace is practicing reuse. Using of PPE kit is recommended in case of contagious disease (SARS Virus, COVID-19, etc.)

### Donning on surgical gloves:

Surgical gloves are cuffed to make it easier to put them on without contaminating them. When putting on surgical gloves, remember that the first step should be thorough hand washing. Glove should be picked up by the cuff only. Only the other glove should then touch the second glove. Remember that the outside of the glove package is not sterile. If you will open the outer package of gloves yourself, do so before you perform a surgical scrub.

### Removing contaminated surgical gloves (doffing)

As you remove the gloves, do not allow the outside surface of the gloves to come in contact with your skin. Avoid letting the gloves snap, as this may cause contaminants to splash into your eyes or mouth or onto your skin or other people in the area. Remove used gloves before touching anything: countertops, faucets, and pens and pencils are frequently contaminated because health care workers touch them while wearing used gloves.

More than one donning method may be acceptable. Training and practice using your healthcare facility's procedure is critical. Below is one example of donning.

### Surgical site infection and its prevention

It is defined as an infection that occurs within 30 days after the operation and involves the skin and subcutaneous tissue of the incision (superficial incisional) and/or the deep soft tissue (for example, fascia, muscle) of the incision (deep incisional) and/or any part of the anatomy (for example, organs and spaces) other than the incision that was opened or manipulated during an operation (organ/space).

SSIs are associated with longer postoperative hospital stays, may necessitate additional surgical procedures and may require intensive care. SSIs result in higher attributable morbidity and mortality.

S NO.	PRE OP MEASURES	ADVICE/ACTIVITY
1.	Pre op bathing	It is good clinical practice for patients to bathe or shower prior to surgery. Either plain soap or an antimicrobial soap may be used for this purpose.
2.	Optimal timing for preoperative surgical antibiotic prophylaxis	Surgical antibiotic prophylaxis within 30-60 minutes before incision, while considering the half-life of the antibiotic. Repeating Antibiotic is indicated in surgeries where the operative time exceed two half-lives of the drug. The Antibiotic should also be repeated in adults if the surgical procedures in which causes excessive blood loss (>1500 mL)
3.	Hair removal	In patients undergoing surgical procedure, hair should either not be removed or, if absolutely necessary, it should be removed only with a clipper. Shaving is strongly discouraged at all times, whether preoperatively or in the operating room.
4.	Surgical site preparation	Recommended are alcohol-based antiseptic solutions based on Chlorhexidine based alcohol solutions for surgical site skin preparation in patients undergoing surgical procedures.

5.	Surgical hand preparation	Preparation should be performed by scrubbing with either a suitable antimicrobial soap and water or using a suitable alcohol-based hand rub before donning sterile gloves.
----	---------------------------	--

Additionally

Maintenance of patient normothermia

Avoidance of hyperglycemia

Supplemental oxygen to patients undergoing surgery

Scrubs – not to take outside operation theatre and bring back to OT

Limiting unnecessary traffic in OT

### Part preparation for surgical intervention:

Preparation with antiseptics before a clinical or surgical procedure is critical, since bacteria from a patient's skin or mucous membrane cause infection.

Shaving the surgical/ procedure site is no longer recommended because it causes small nicks and breaks in the skin where bacteria can grow and multiply, and it can lead to increased risk of post procedure infections. Hair round the surgical/ procedure site may be clipped very short if it interferes with the procedure. If the shaving is inevitable: 1) use antimicrobial soap and water or shave dry, and 2) shave immediately before the procedure, in the operating theatre or procedure room.

### Surgical/ procedure site preparation:

1. Wash the area with soap and water.

2. Apply the antiseptic (Chlorhexidine based alcohol solution) and gently scrub the skin in the circular motion, beginning in the centre of the site and moving out, using sterile cotton balls, cotton wool, or gauze sponge forceps.

For the vagina, cervix, and other mucous membranes: Do not use alcohol or alcohol-based antiseptics on mucous membranes. Using sterile cotton balls, cotton wool, or gauze sponges held by forceps, apply an antiseptic liberally to the cervix and vagina before instrumentation of the uterus.

Procedure	Agent used
Part preparation for surgery	Clean with 70% isopropanol or ethyl alcohol or 2% w/v chlorhexidine with 70% isopropanol followed by painting with 10% povidone iodine (Do not use alcohol at mucous membranes)

### 3. Sharp injuries:

Health care workers can accidentally stick each other when passing sharps during a procedure.

This can cause risk of exposure to various blood borne infections like Hepatitis B, Hepatitis C, HIV. As per the data reported by CDC 2008, 41% injuries take place while using sharps, 40% after use and before disposal of sharps and 15% during or after appropriate or inappropriate disposal.

So, it is desirable that always pass sharps in such a way that the surgeon and assistant are never touching the item at the same time. This is known as the "hands-free" technique.

To avoid injuries while handling sharps:

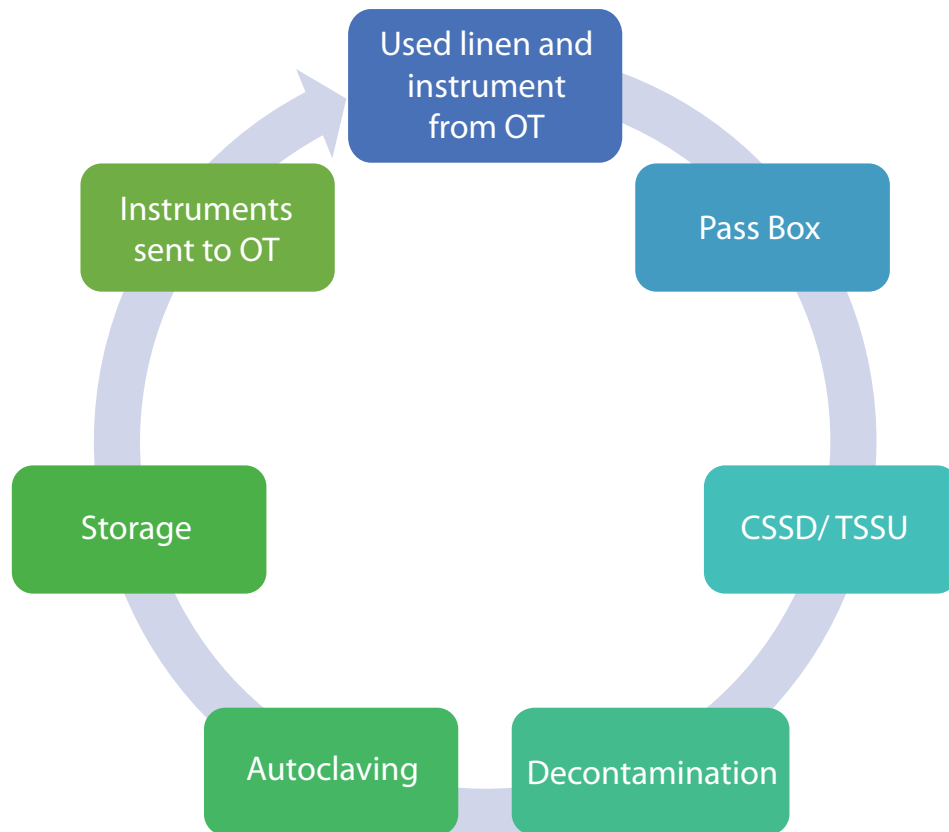
- Do not recap the used needles.

- Do not bend, cut, or break needles.
- Do not remove needles from syringes before disposal.
- Dispose off sharp in a puncture-resistant sharps container; such as a metal box, heavy cardboard box, or an empty plastic jug.
- Wear utility gloves when disposing of sharps containers.

#### 4. Processing instruments / equipment and linens

The instrument and linen should be transported to CSSD and Mechanized laundry for sterilization as per following activities:

- All used linen must first be segregated into soiled & non-soiled. Soiled ones are first put into 0.5% chlorine solution for 30 min and then sent to mechanized laundry. The non-soiled can be sent directly after packing in a zip bag. All personnel working in OT should follow source segregation and put the discarded or reusable linen in correct bins or bags.
- All linen used in procedures in the OT (e.g., surgical drapes, gowns, wrappers) are considered to be infectious even if there is no visible stain.
- Disposal Zone of OT is where all the used linen is collected.
- Ideally, the pathways for delivery of clean and sterile equipment and linen and collection of dirty equipment and linen should not cross each other. As far as practicable, this protocol needs to be adhered to. There should be a separate window for receiving and dispatching of items.
- The transportation of materials should be done through a defined corridor/dumb waiter/ service lift in a clean and covered trolley. The trolleys should be cleaned/washed with damp mop with detergent/alcohol and water. Clean the wheels by running them 10-15 times over a Turkish towel (cotton, soft and absorbent) soaked with soap and water. persons transporting these trolleys should wear personal protective attire.
- The linen bag must be tied once 2/3rd full and taken to the appropriate area to store neatly. Any bag which is overfilled shall be split into two bags.
- The laundry staff shall use gloves while handling the linen and check for any damage or tear, if any.
- The ward/OT staff nurse shall be present during the collection to check the count of linen and damage if any. She shall then mention details in the linen book, sign, take signature of the laundry staff too, and handover a copy to the laundry staff.
- All the linen is transported in closed leak proof bags, containers with lids or covered carts via dumb waiters/ dedicated elevators or corridors to washing area. Contaminated and non-contaminated linen is transported separately.
- After this the linen/ instruments are sterilized at Mechanized Laundry and CSSD.



## B. Routine cleaning

### 1. Maintaining correct environmental cleanliness

General principles for cleaning of OT:

- Cleaning is an essential first step prior to any disinfection process to remove dirt, debris and other materials.
- The use of a neutral detergent solution is essential for effective cleaning. It removes dirt while improving the quality of cleaning by preventing the build-up of biofilms and thus increasing the effectiveness of chemical disinfectants.
- If disinfectants are used, they must be prepared and diluted correctly as too high and/or too low concentrations reduce the effectiveness of disinfectants. In addition, high concentrations of disinfectant may damage surfaces.
- Cleaning should always start from the least soiled areas (cleanest) first to the most soiled areas (dirtiest) last and from higher levels to lower levels so that debris may fall on the floor and is cleaned last.
- Detergent and/or disinfectant solutions must be discarded after each use.
- Avoid cleaning methods that produce mists or aerosols or disperse dust, for example dry sweeping (brooms, etc.), dry mopping, spraying or dusting.
- Routine bacteriological monitoring to assess the effectiveness of environmental cleaning is not required but may be useful to establish the potential source of an outbreak and/or for educational purposes.

**Fumigation/ fogging:**

Fogging is no more recommended as a routine procedure in International Infection Control

Guidelines including those by CDC as the developed countries have all modern critical parameters required for OT with a well-equipped Heat Ventilation Air Conditioning (HVAC) system except in special circumstances as such as after construction/ renovation and/ or major civil and maintenance work, while commissioning new OT or reporting of any infection in the OT.

The method of fogging is recommended mainly to ensure uniform application of the disinfectant to all surfaces in the room. At the same time, the age-old tradition of formalin fumigation is not recommended as it is difficult to perform, dangerous to use (especially the liquor ammonia), unreliable (as conditions required for bactericidal activity are difficult to maintain) and formalin itself is carcinogenic.

***This guideline recommends the use of hydrogen peroxide for fogging, but at least one of the following conditions hasve to be met for fogging to be done otherwise routine fogging is not recommended.***

1. Fogging is not required for an OT with a HEPA filtered positive pressure air supply system.
2. OT which do not have a HVAC/HEPA filter system.
3. Commissioning a new OT /renovation or other civil works/ outbreak of disease
4. In case validation of HVAC/HEPA has not taken place, as per Validation criteria led down in the guideline

The steps for fogging are mentioned below:

- i. Wear a gown, cap, mask and utility gloves.
- ii. Clean blood spills, remove waste, clean and disinfect items used in surgery.
- iii. Inspect all surfaces in the OT in detail for visible soiling/dust. Clean any soiling with a disinfectant.
- iv. Wipe and clean all equipment completely i.e. wipe the entire OT table, OT lights, trolleys, anesthesia machine
- v. Lastly, clean and mop the floor twice (scrub by hand or a floor scrubber machine if possible) with 0.5% chlorine solution beginning at the end farthest from the door and moving towards it.
- vi. Cover all electronic equipment with plastic covers. The fogging liquid should not enter them.
- vii. Turn off the ventilation system.
- viii. Fog the OT with solution of hydrogen peroxide until a fog is seen in the air.
- ix. Stop the fogging and exit from the OT with the machine.
- x. Thereafter, the OT should be closed.
- xi. The OT should not be entered after it has been closed down for the day (except for emergency cases).

### **C. Sterilisation**

- It has been recommended that since anaesthesia equipment is exposed to a heavily contaminated area of the body, meticulous care should be exercised in the handling and sterilisation of apparatus.
- Sterilisation of anaesthesia equipment presents a rather difficult problem. Although certain items can apparently be sterilised by satisfactory techniques, bulky rubber items do not lend themselves to these techniques, and, in addition, must be processed in considerable quantity to meet the demands of a busy operating schedule. Germicides which are effective against

certain organisms under certain conditions may be unsatisfactory under other conditions. The first and foremost step in decontamination is a thorough cleaning. In some cases, cleaning may be sufficient to render an item ready for use. It is important to prevent blood and other body fluids from drying on the surface. Enzyme foam sprays that prevent drying, breakdown blood and inhibit bacterial growth are available. Items that can be immersed should be soaked in water plus an enzyme with or without detergent for at least 3 minutes. Stainless steel or other metal devices should not be soaked in saline or sodium hypochlorite solutions because the chloride ions in these substances will cause the metal to corrode.

- The Anaesthesia machine should be cleaned according to the instructions given in its manual, which generally consists of simple soap and water.
- The hard objects in use such as laryngoscopes and bougies could be cleaned with alcohol-containing disinfectants and then with water.
- ET tubes, oral airway, suction catheters etc. should be for single use. However, items like the LMA may be reused after washing it with soap and water.
- With regards to the sterilisation of the operation theatre, any local protocol using environment-friendly disinfectants may be used based on the local practice and availability.

#### Further readings

- Miller – Anesthesia.
- Clinical Anesthesia (Barash).

Activity	Agent used	Frequency
<b>Floor Mopping (include blood spill)</b>	Routine cleaning morning, evening and once in two hours. Damp mop with detergent and water followed by aldehyde free high-level disinfectant/0.5% chlorine in areas other than operative zone.	4hourly apart from that as and when required in case of blood spill.
<b>Furniture</b>	Ethyl alcohol (70-90%) Sodium hypochlorite or (5.25-6.15% household bleach diluted 1:500 provides >100 ppm available chlorine)	Morning and Evening
<b>Metallic surfaces.g. OT tables and stretchers/ metallic surfaces</b>	Metallic surfaces eg. OT tables and stretchers/ metallic surfaces- 70% ethyl or isopropyl alcohol after every procedure	Morning, evening and after every procedure
<b>Bed rails</b>	1% Sodium hypochlorite	Morning, evening and before allotting the bed to a patient
<b>Bed pans</b>	3-5 % Sodium hypochlorite for 30 minutes followed by washing with soap and water	Morning and evening, as and when required
<b>Soiled linen</b>	Hot water washing for 25 minutes at 71 degree celsius. Use of chlorine assures an extra margin of safety. Addition of 50-150 ppm (0.015% hypochlorite) available chlorine residual is recommended.	As and when required

Activity	Agent used	Frequency
<b>Cleaning of Mops</b>	<p>Disinfect mop by soaking them in water with 0.5% hypochlorite solution for 30 minutes. Wash with detergent and water and dry in sunlight upwards down at 45 degree angle. Use separate mop for surfaces and floor Separate mops for critical areas. Immerse in detergent solution and use mechanical action (e.g., scrubbing) to remove soil.</p> <p>Disinfect by:</p> <ul style="list-style-type: none"> <li>• fully immersing the items in boiling water or</li> <li>• fully immersing in hypochlorite solution (4000 ppm) for 2 minutes and rinsing with clean water to remove residue</li> </ul> <p>Allow to fully dry</p> <ul style="list-style-type: none"> <li>• Lay items to dry in a clean and dry area to prevent recontamination.</li> </ul> <p>☉ Position mops with the head up to allow the mop head to fully dry.</p>	After every use
<b>Instruments</b>	<p>All equipment and instruments to be decontaminated and cleaned with aldehyde free high-level disinfectant like 70% isopropyl alcohol, cleaned with detergent and plain water followed by autoclaving except heat-sensitive equipment &amp; instruments.</p> <p>Cleaning of the instruments with detergent &amp; water followed by decontamination with 70% isopropyl alcohol along with parallelly decontaminating the contaminated liquid waste is the most appropriate way for the instruments before autoclaving.</p> <p>In case the liquid waste management system is not in place at the health care facility, or a very large amount of liquid waste is being generated then instruments need to be decontaminated liquid waste.</p> <ol style="list-style-type: none"> <li>1. Cleaning is the first and most essential step before any process of disinfection or sterilization can be carried out.</li> <li>2. Soaking of instruments in 0.5% chlorine solution or any other disinfectant before cleaning is not recommended.</li> <li>3. Medical devices/instruments which are grossly soiled should first be cleaned by rinsing with detergent and water. If blood or exudates have dried or hardened, soaking in a warm solution of an enzymatic cleaner is required.</li> </ol>	After every procedure



Activity	Agent used	Frequency
	<p>4. After cleaning, sterilization needs to be done by autoclaving and in case of heat sensitive equipment by ETO.</p> <p>5. For, instruments like endoscope, high level disinfection with glutaraldehyde, ortho-phthaldehyde, peracetic acid is used.</p>	
<b>Buckets and Utility Gloves</b>	<p>Disinfect buckets and utility gloves with 0.5 % hypochlorite solution for 1 minute</p> <ul style="list-style-type: none"> <li>• Wash the utility gloves with soap and water and hang for drying</li> </ul>	After Every Use
<b>Laparoscopy/ endoscopy disinfection</b>	2% glutaraldehyde for 20 mins (ensure that the device was first cleaned)	After every procedure
<b>Rectal/vaginal probes, cryosurgical instruments, and diaphragm fitting rings</b>	3% hydrogen peroxide, or 5000 ppm chlorine, or 70% ethyl alcohol, or 70% isopropyl alcohol	After every procedure
<b>Rubber/ polyethylene Tubing and Catheters</b>	ETO is preferred OR else soak in 2% glutaraldehyde for 20mins (ensure that the device was first cleaned)	After every procedure

Surface Type	Definition	Cleaning requirement
High hand-touch surface	Any surface with frequent contact with hands.	Requires special attention and more frequent cleaning. After thorough cleaning, consider the use of appropriate disinfectants to decontaminate these
Minimal touch surface (floors, walls, ceilings, window sills, etc.)	Minimal contact with hands. Not in close contact with the patient or his/her immediate surroundings.	Requires cleaning on a regular basis with detergent only or when soiling or spills occur. Also required following patient discharge from the health care
Toilet area		Clean toilet areas at least twice daily

Surface Type	Definition	Cleaning requirement
Medical and other equipment		Require cleaning according to written protocols (for example, daily, weekly, after each patient use, etc.). This should include the use of appropriate personal protective equipment, cleaning methods conforming to the type/s of surface and cleaning schedules, etc. Schedules and procedures should be consistent and updated on a regular basis and education and training must be provided to all cleaning staff. Please refer to the manufacturer's instructions for medical equipment to ensure that the item is not damaged by the use of disinfectants.
Surface contaminated with blood and body fluids	Any areas that are visibly contaminated with blood or other potentially infectious materials.	Requires prompt cleaning and disinfection.

### Monitoring quality in OT

- OT needs to be continuously and routinely monitored for its infection prevention control protocol adherence through supervisory rounds by NS/ DNS, Hospital Manager and OT in-charge.
- Routine cleaning of OT should be done.
- In any OT chances of infection is decrease or minimize if we are able to maintain the temperature and humidity of OT as well as ensure the mean required air exchange.
  - a. Temperature of OT should be adjusted between 21 degrees Centigrade +/- 3 degree Centigrade according to requirement of patient, especially in pediatric, geriatric, burns, neonatal cases etc.
  - b. Relative humidity of 20-60% to be maintained though the ideal RH is considered to be 55%.
  - c. Air should be circulated by positive pressure through high efficiency particulate air (HEPA) filters and ventilation rate should be 20 air exchange per hour

### 2. Biomedical Waste Management (BMW)

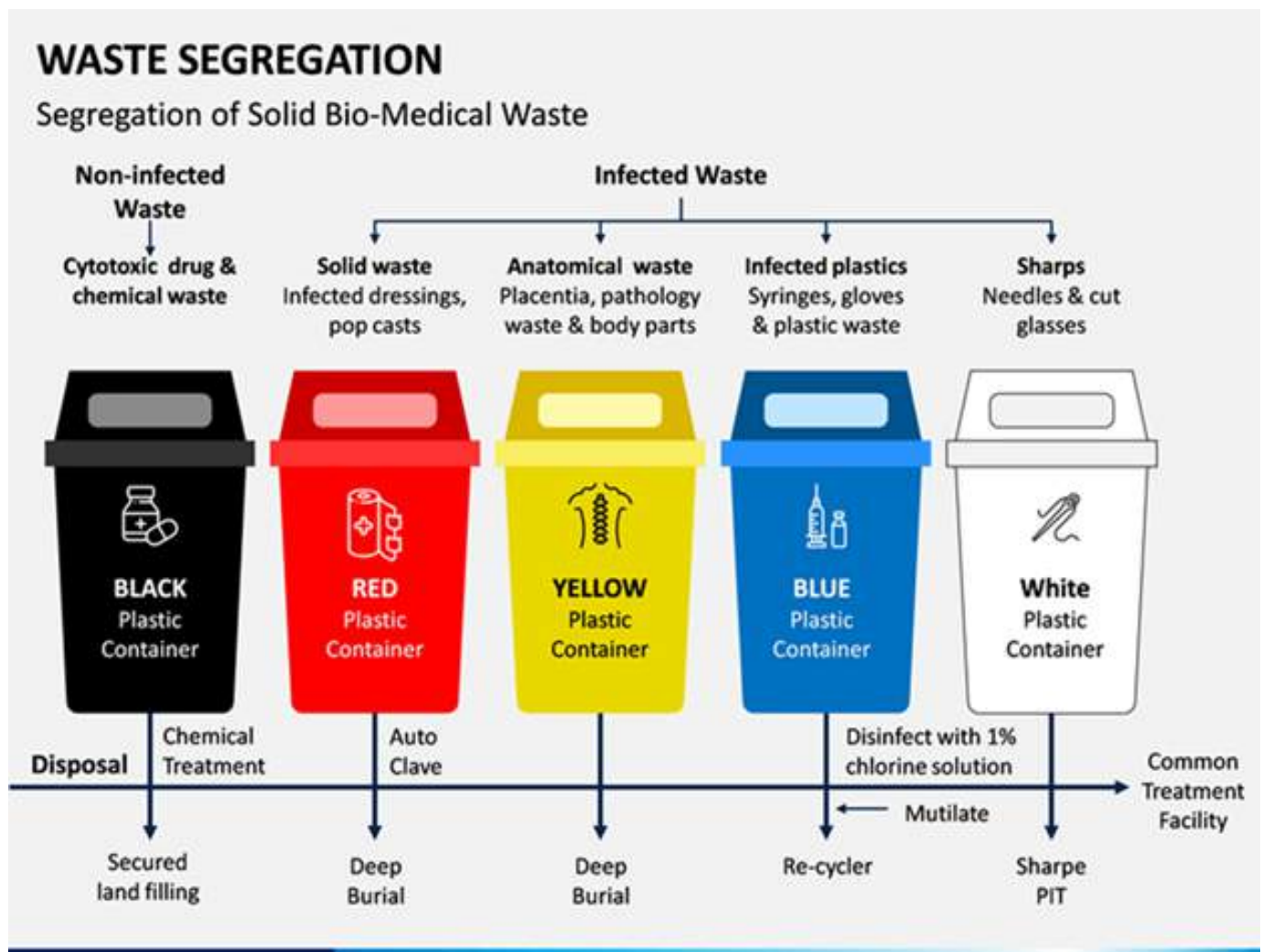
Hospital waste is a potential reservoir of pathogenic microorganisms and requires appropriate, safe and reliable handling. The main risk associated with infection is sharps contaminated with blood. There should be a person or persons responsible for the organization and management of waste collection, handling, storage and disposal. Waste management should be conducted in coordination

with the infection control team. Care of HCWs handling BMW Precautions to be taken by HCWs Immunization of HCWs.

**Definitions:**

Bio-medical waste is defined as any waste, which is generated during the diagnosis, treatment or immunization of human beings or animals or research activities pertaining thereto or in the production or testing of biological or in health camps

Bio-Medical Waste Treatment and Disposal Facility is defined as any facility wherein treatment, disposal of bio-medical waste or processes incidental to such treatment and disposal is carried out, and includes common bio-medical waste treatment facilities.



## ANNEXURE-1

### Biomedical Waste Management

Category	Waste	Type of bag or Container to be used	Options
1	2	3	4
Yellow	a. Human Anatomical Waste: Human tissues, organs, body parts and fetus below the viability period (as per the Medical Termination of Pregnancy Act 1971, amended from time to time).	Yellow Colored non-chlorinated plastic bags	Incineration or Plasma Pyrolysis or deep burial
	b. Animal Anatomical Waste: Experimental animal carcasses, body parts, organs, tissues including the waste generated from animals used in experiments or testing in veterinary Hospitals or Colleges or animal Houses.		
	c. Soiled Waste: Items contaminated with blood, body fluids like dressings, plaster casts, cotton swabs and bag containing residual or discarded blood and blood components		Incineration or Plasma Pyrolysis or deep burial. In absence of above facilities, autoclaving or microwaving/ hydroclaving followed by shredding or mutilation or combination of sterilization and shredding. Treated waste to be sent for energy recovery
	d. Expired or discarded medicines: Pharmaceutical waste like antibiotics cytotoxic drugs including all items contaminated with cytotoxic drugs along with glass or plastic ampoules, vials etc.	Yellow Colored non-chlorinated plastic bags or containers	Expired 'cytotoxic drugs and items contaminated with cytotoxic drugs to be returned back to the manufacturer or supplier for incineration at temperature > 1200°C or to common biomedical waste treatment facility or Hazardous waste treatment, storage and disposal facility for incineration at > 1200°C or encapsulation or plasma pyrolysis at >1200°C.

Category	Waste	Type of bag or Container to be used	Options
			<p>Expired 'cytotoxic drugs and items contaminated with cytotoxic drugs to be returned back to the manufacturer or supplier for incineration at temperature &gt; 1200°C or to common biomedical waste treatment facility or Hazardous waste treatment, storage and disposal facility for incineration at &gt; 1200°C or encapsulation or plasma pyrolysis at &gt;1200°C.</p> <p>All other discarded medicines shall be either sent back to manufacturer or dispose by incineration</p>
	e. Chemical Waste: Chemicals used in production of biological and used or discarded disinfectants.	Yellow Colored containers or non-chlorinated plastic bags.	Disposed of by incineration or plasma pyrolysis or encapsulation in Hazardous waste treatment, storage and disposal facility.
	f. Chemical Liquid waste: Liquid waste generated due to use of chemicals in production of biological and used or discarded disinfectants, Silver X-Ray film developing liquid, discarded formalin, infected secretions aspirated body fluids, liquids from laboratories and floor washing cleaning, house- keeping and disinfecting activities etc.	Separate collection system leading to effluent treatment system	After resource recovery, the chemical liquid waste shall be pre-treated before mixing with other waste water. The combined discharge shall conform to the discharge norms given in Schedule-III.
	g. Discarded linen, disinfection mattresses, bleeding contaminated with blood or body fluids, routine mask & gown.	Non-chlorinated yellow plastic bags or suitable packing materials	<p>Non-chlorinated chemical followed by incineration or plasma pyrolysis or for energy recovery.</p> <p>In absence of above facilities, shredding or mutilation or combination of sterilization and shredding. Treated waste to be sent for energy recovery or incineration or Plasma Pyrolysis.</p>

Category	Waste	Type of bag or Container to be used	Options
	<p>h. Microbiology, Biotechnology and other clinical laboratory waste: Blood bags, Laboratory cultures, stocks or specimens of micro-organisms, live or attenuated vaccines, human and animals cell cultures used in research, industrial laboratories, production of biological, residual toxins, dishes and devices used for cultures.</p>	Autoclave or Microwave or Hydroclavesafe plastic bags or containers	Pre-treat to sterilize with non-chlorinated chemicals on-site as per World Health Organization guidelines and thereafter sent for incineration
Red	<p>i. Contaminated Waste(Recyclable): Wastes generated from disposal items such as tubing, bottles, intravenous tubes and sets, catheters, urine bags, syringes (without needles and fixed needle syringes and vaccutainers with their needles cut) and gloves.</p>	Red colored non-chlorinated plastic bags or containers	<p>Autoclaving or micro-waving/hydroclaving followed by shredding or combination of sterilization and shredding .Treated waste to be sent to registered or authorized recyclers or for energy or plastics to diesel or fuel oil or for road making, whichever is possible. Plastic waste should not be sent to landfill sites.</p>
White	<p>j. Waste sharp including metals: Needles, syringes with fixed needled, needles from needle tip cutter or burner, scalpels, blades, or any other contaminated sharp objects that may cause puncture and cuts. This includes both used, discarded and contaminated metal sharps</p>	Puncture proof, Leak proof, tamper proof containers	<p>Autoclaving or dry heat sterilization followed by shredding or mutilation or encapsulation in metal containers or concrete cement, combination of shredding cum autoclaving and sent for final disposal to iron foundries(having consent to operate from the State Pollution Control Boards or Pollution Control Committees) or sanitary landfill or designated concrete waste sharp pit.</p>

Category	Waste	Type of bag or Container to be used	Options
Blue	k. Glassware: Broken or discarded and contaminated glass including medicine vials, metallic body implants and ampoules except those contaminated with cytotoxic wastes.	Puncture proof and leak proof boxes or containers with blue colored marking.	Disinfection soaking (by the washed glass waste after cleaning with detergent and Sodium Hypochlorite treatment) or through autoclaving or microwaving or hydroclaving and then sent for recycling.
	l. Metallic Body Implants	Puncture proof and leak proof boxes or containers with blue colored marking	



## ANNEXURE-2

### CHECKLIST FOR STERILE SUPPLY DEPARTMENT

CHECKPOINTS (PROCESS)	YES/NO (COMMENTS)
1)SOP for CSSD is available and the SOP adequately describes the processes of CSSD.	
2a) SOP adequately describes the process of Transfer of unsterile items from user department to CSSD.	
2b) Staff follows and adheres to the same, in day-to-day practices.	
3a) SOP adequately describes the process of Transfer of sterile items from CSSD to user departments.	
3b) Staff follows and adheres to the same, in day-to-day practices.	
4a)SOP adequately describes the process of Standardized list of the contents of sets/trays for various procedures.	
4b) Staff maintains and adheres to the same, in day-to-day practices.	
5a) SOP adequately describes the process of Sterilization process for different categories of items. (Linen, gauze, equipment, rubber materials, catheter).	
5b) Staff follows and adheres to the same, in day-to-day practices.	
6a) SOP adequately describes the Complete process cycle from start to finish (washing, cleaning, sterilization, storage and issue).	
6b) Staff follows and adheres to the same, in day-to-day practices including 6b.1 Drying, packaging and labelling of items 6b.2 Application of Autoclave indicator 6b.3 Setting up autoclaving parameters (Preheating & loading, ensuring time, temperature and pressure) / different for linen and equipment/ different for packed and open items) 6b.4 Unloading and storing in a sterile area/rack	
7a) SOP describes the process of Internal validation of sterilization process	
7b) Staff follows and adheres to the same, in day-to-day practices (heat sensitive indicators strips, Bowie Dick Test)	
8)Soiled items are contained during transportation (closed drums/ packed/enclosed in tray)	
9) Appropriate personal protective equipment (PPE) are used in the entire procedure of sterilization	
10) Cleaning agents are used according to manufacturer's instructions	
11)Appropriate manual/ mechanical cleaning methods are used for decontamination	
12) Inspection for functionality, defects/breakage is been done	

<p>13) Fixing of shelf life of different sterile items. System of recall of items from user department, if their sterile status is in doubt.</p> <p>13.1 Sterile items are stored in a way to facilitate First-In First-Out (FIFO). 13.2 SOP for maintenance and calibration of equipment.</p>	
<p>14) There is a separate register/records for various activities on daily basis of the following:</p> <p>14.1 Each cycle of autoclave 14.2 Maintenance and breakdown of equipment 14.3 Stock maintenance for the consumables 14.3 Recording fumigation details 14.5 Periodic cleaning of the autoclave and other equipment like drums shelves 14.6 Default sterilization/ sterilization defects</p>	
<p>15) Regular training of the staff on carrying out various process of sterilisation, infection control practices, Biomedical Waste Management, trouble shooting of equipment, handling instruments, record keeping and reporting mechanism etc.</p>	

CHECKPOINTS (OUTPUT)	COMMENTS
1. Number of sterilisation cycle per day/autoclave	
2. Percentage of cycles wherein in standards norms of temperature, pressure and time were adhered and recorded.	
3. Number of sterilisation failure/default sterilization cases noted/day	
4. Percentage re-sterilisation required due to improper storage	

### ANNEXURE-3

Handing Over /Taking Over Checklist of Critical Equipment					
S. No.	Name of Equipment	Signature			Remarks
		Morning	Evening	Night	
1	Anaesthesia Trolley				
2	Difficult Airway Trolley- Bronchoscope, LMAs and intubating bougie				
3	Anaesthesia work station				
4	Electrical Suction				
5	Laryngoscope with 5 Blades (LED)				
6	Defibrillator ( AED plus Manual with ECG)				
7	Surgical Diathermy - Bipolar				

**Week 13 & 14**

**Revision of any chapters**



## List of Abbreviations

5-HT3	5-Hydroxytryptamine
AABB	American Association of Blood Banks
ABCDE	Airway, Breathing, Circulation, Disability, Exposure
ABG	Arterial Blood Gases
AC	Alternating Current
ACEIs	Angiotensin-Converting Enzyme Inhibitors
ACLS	Advanced Cardiovascular Life Support
ADH	Anti-Diuretic Hormone
ADSOL	Adenine, Dextrose, Sorbitol, Sodium chloride & Mannitol
AED	Automated External Defibrillator
AHA	American Heart Association
AHU	Air Handling Unit
AIDS	Acquired Immunodeficiency Syndrome
AIIMS	All India Institute of Medical Sciences
AMBU	Artificial Manual Breathing Unit
APGAR	Appearance, Pulse, Grimace, Activity, and Respiration
APL	Adjustable Pressure Limiting Value
aPTT	Activated Partial Thromboplastin Time
ARBs	Angiotensin Receptor Blockers
ARDS	Acute Respiratory Distress Syndrome
ASA	American Society of Anesthesiologists
ASTM	American Society of Testing and Material
ATP	Adenosine Triphosphate
BBB	Blood Brain Barrier
BCLS	Basic Cardiac Life Support
BCSH	British Committee for Standards in Haematology
BLS	Basic Life Support
BMR	Basal Metabolic Rate
BMV	Bag and Mask Ventilation
BMW	Bio- Medical Waste
BP	Blood Pressure
bpm	beats per minute
BUN	Blood Urea Nitrogen
BURP	Backwards Upwards Rightwards Pressure
C <sub>3</sub> H <sub>6</sub>	Propene
Ca	Calcium
CBF	Cerebral Blood Flow
CCF	Congestive Cardiac Failure
CDC	Centre for Disease Control
CGHS	Central Government Health Scheme
cGy	Centigray
CHC	Community Health Centre

CHF	Congestive Heart Failure
Cl	Chloride
CNS	Central Nervous System
CO	Cardiac Output
CO <sub>2</sub>	Carbon Dioxide
COPD	Chronic Obstructive Pulmonary Disease
COVID	Coronavirus Disease
CPD	Citrate Phosphate Dextrose
CPDA-1	Citrate Phosphate Dextrose Adenine Solution
CPR	Cardio-Pulmonary Resuscitation
Cr	Chromium
CRP	C-reactive Protein
CSF	Cerebrospinal Fluid
CSSD	Central Sterile Services Department
CT	Computed Tomography
CTMO	Catechol-O-Methyltransferase
CTZ	Chemoreceptor Trigger Zone
CVA	Cerebrovascular Accident
CVP	Central Venous Pressure
CVS	Cardiovascular System
CXR	Chest Xray
D10W	Dextrose 10% in Water
D5	Dextrose 5%
D5NS	Dextrose 5% in Normal Saline
D5W	Dextrose 5% in Water
DC	Direct Current
DDG	Deputy Director General
DIC	Disseminated Intravascular Coagulation
DISS	Diameter Indexed Safety System
DNS	Dextrose Normal Saline
DVT	Deep Vein Thrombosis
ECF	Extracellular Fluid
ECG	Electrocardiogram
ECMO	Extracorporeal Membrane Oxygenation
ED50	Median Effective Dose
EDTA	Ethylenediaminetetraacetic acid
EMS	Emergency Medical Services
EMT	Emergency Medical Technician
ERV	Expiratory Reserve Volume
ET	Endo-Tracheal
EtCO <sub>2</sub>	End-Tidal Carbon Dioxide
ETT	Endotracheal Tube
EU	European Commission
EVA	Electric Vacuum Aspiration

FAS	Facial drop, Arm drift, Speech difficulties
FAST	Focused Assessment with Sonography in Trauma
FDA	Food and Drug Administration
FEV1	Forced Expiratory Volume 1
FFP	Fresh frozen plasma
FIFO	First-In First-Out
FiO <sub>2</sub>	Fraction of Inspired Oxygen
FNHTRs	Febrile Nonhemolytic Transfusion Reactions
FRC	Functional Residual Capacity
FRU	First Referral Units
FVC	Forced Vital Capacity
GA	General Anesthesia
GFR	Glomerular Filtration Rate
GIT	Gastrointestinal Tract
GVHD	Graft versus Host Disease
Gy	Gray (unit)
H <sub>2</sub> O	Water
HAI	Hospital Acquired Infection
HCl	Hydrochloric Acid
HCO <sub>3</sub>	Bicarbonate
HCV RNA	Hepatitis C Virus- Ribonucleic acid
HDU	High Dependency Unit
HELLP	Haemolysis, Elevated Liver Enzymes, Low Platelet Count
HEPA	High-Efficiency Particulate Air
HFNC	High-Flow Nasal Cannula
HIV	Human Immunodeficiency Virus
HIV-1 RNA	Human Immunodeficiency Virus-1 Ribonucleic Acid
HLA	Human Leucocyte Antigen
HME	Heat Moist Exchanger
HOD	Head of Department
HR	Heart Rate
HTLV	Human T-cell Lymphotropic Virus Type 1
HVAC	Heat Ventilation Air Conditioning
I- GEL	Innovative Second Generation Supraglottic Airway Device
I/O	Input/Output
IBP	Invasive Blood Pressure
IBW	Ideal Body Weight
IC	Inspiratory Capacity
ICF	Intracellular Fluid
ICP	Intracranial Pressure
ICU	Intensive Care Unit
IHCA	In-hospital Cardiac Arrest
ILCOR	International Liaison committee on Resuscitation
IM	Intramuscular



INR	International Normalized Ratio
IOP	Intraocular Pressure
IPC	Indian Penal Code
IPPV	Intermittent Positive Pressure Ventilation
IRV	Inspiratory Reserve Volume
ISA	Indian Society of Anesthesiologists
IV	Intravenous
IVF	Intravenous Fluid Rate
IVRA	Intravenous Regional Anesthesia
JVP	Jugular Venous Pressure
K	Potassium
KCl	Potassium Chloride
kg	Kilogram
LA	Local Anaesthesia
LABAs	Long-Acting Beta-Agonists
LED	Light Emitting Diode
LMA	Laryngeal Mask Airway
LOS	Lower Oesophageal Sphincter
LPM	Liters Per Minute
LR	Lactated Ringers solution
LSAS	Life Saving Anesthesia Skills
LSCS	Lower (uterine) Segment Caesarean Section
LUD	Left Uterine Displacement
LVEDP	Left Ventricular End-Diastolic Pressure
MAC	Minimum Alveolar Concentration
MAOIs	Monoamine Oxidase Inhibitors
MBBS	Bachelor of Medicine, Bachelor of Surgery
mcg	Microgram
NMC	Medical Council of India
MDI	Metered Dose Inhaler
mEq	Milliequivalents
mg	Milligram
MgSO <sub>4</sub>	Magnesium Sulfate
MI	Myocardial Infarction
MIVF	Maintenance Intravenous Fluid
ml	Millilitre
mmol/l	millimoles/litre
MO	Medical Officer
mOsm/kg	milliosmoles per kilogram
MSAF	Meconium Stained Amniotic Fluid
MTP	Massive haemorrhage and Massive Transfusion protocol
N <sub>2</sub> O	Nitrous Oxide
Na	Sodium
NaCl	Sodium Chloride

NCDRC	National Consumer Disputes Redressal Commission
NG	Nasogastric
NIBP	Non-invasive Blood Pressure
NIHFW	National Institute of Health & Family Welfare
NMB drugs	Neuromuscular-Blocking Drugs
NMDA	N-methyl-D-aspartate
NO	Nitric Oxide
NPO	Nil Per Oral
NS	Normal Saline
NTG	Nitroglycerine
OELM	Optimum External Laryngeal Manipulation
OHCA	Out of Hospital Cardiac Arrest
ORM	Oxygen Ratio Monitor
ORMC	Oxygen Ratio Monitor Controller
OT	Operation Theatre
PAC	Pre-Anaesthetic Checkup
PACO <sub>2</sub>	Partial Pressure of Carbon Dioxide
PACU	Post Anaesthesia Care Unit
PAO <sub>2</sub>	Partial Pressure of Oxygen
pCO <sub>2</sub>	Partial Pressure of Carbon Dioxide
PDPH	Postdural Puncture Headache
PE	Pulmonary Embolism
PEA	Pulseless Electrical Activity
PEEP	Positive End-Expiratory Pressure
PETCO <sub>2</sub>	End Tidal Carbon Dioxide
pH	Potential of Hydrogen
PID	Pelvic Inflammatory Disease
PiO <sub>2</sub>	Partial Pressure of Inspired Oxygen
PMCD	Perimortem Cesarean Delivery
PMCS	Perimortem Caesarian Section
POC	Point of Care
PONV	Postoperative Nausea And Vomiting
PPC	Postoperative Pulmonary Complication
PPE	Personal Protective Equipment
PPH	Postpartum Hemorrhage
PPV	Positive Pressure Ventilation
PRBC	Packed Red Blood Cells
PSIG	Pounds per square in gauge
PSVT	Paroxysmal Supraventricular Tachycardia
PT	Prothrombin Time
PVD	Peripheral Vascular Disease
RA	Regional Anesthesia
RBC	Red Blood Cells
RBS	Random Blood Sugar

RCH	Reproductive Health & Child Health Programme
RDP	Random Donor Platelets
Rh	Rhesus Antigen
RH	Relative Humidity
RL	Ringers Lactate
RLN	Recurrent Laryngeal Nerve
ROSC	Return of Spontaneous Circulation
RR	Respiratory Rate
RSI	Rapid Sequence Induction
RV	Residual Volume
SaO <sub>2</sub>	Oxygen Saturation
SARS	Severe Acute Respiratory Syndrome
SC	Supreme Court
SDGs	Sustainable Development Goals
SDP	Single Donor Platelet
SGOT	Serum Glutamic-Oxaloacetic Transaminase
SGPT	Serum Glutamic Pyruvic Transaminase
SIADH	Syndrome of Inappropriate Antidiuretic Hormone Secretion
SLE	Systemic Lupus Erythematosus
SLN	Superior Laryngeal Nerve
SNCU	Special Newborn Care Unit
SNRI	Serotonin–Norepinephrine Reuptake Inhibitors
SOP	Standard Operating Procedure
SPIKES	Setting Perception, Invitation or information Knowledge, Empathy and Strategize
SpO <sub>2</sub>	Partial Pressure of Oxygen
SSI	Surgical Site Infection
SSRI	Selective Serotonin Reuptake Inhibitors
ST	Sinus Tachycardia
SV	Stroke Volume
SVR	Systemic Vascular Resistance
TLC	Total Lung Capacity
TSH	Thyroid Stimulating Hormone
TSSU	Theatre Sterile Supply Unit
TTJV	Transtracheal Jet Ventilation
TTM	Targeted Temperature Management
TV	Tidal Volume
UTI	Urinary Tract Infection
UV	Ultra Violet
VBG	Venous blood gas
VC	Vital Capacity
VD	Vaso-dilatation
VF	Ventricular Fibrillation
VF/pVT	Ventricular Fibrillation and Pulseless Ventricular Tachycardia

VMA	Vanillylmandelic acid
VT	Ventricular Tachycardia
VWF	Von Willebrand Factor
WBC	White Blood Cells
WFSA	World Federation of Societies of Anesthesiologists
WHO	World Health Organization





National Health Systems Resource Centre,  
Ministry of Health and Family Welfare, Government of India